

CLASS
6



MATHEMATICS

CLASS VI

MATHEMATICS

2025-26

2025-26



6



State Council of Educational Research and Training
Telangana, Hyderabad



Published by
The Government of Telangana
Government's Gift for Students' Progress



L5S6N3

Energized Text Books facilitate the students in understanding the concepts clearly, accurately and effectively. Content in the QR Codes can be read with the help of any smart phone or can as well be presented on the Screen with LCD projector/K-Yan projector. The content in the QR Codes is mostly in the form of videos, animations and slides, and is an additional information to what is already there in the text books.

This additional content will help the students understand the concepts clearly and will also help the teachers in making their interaction with the students more meaningful.





At the end of each chapter, questions are provided in a separate QR Code which can assess the level of learning outcomes achieved by the students.

We expect the students and the teachers to use the content available in the QR Codes optimally and make their class room interaction more enjoyable and educative.

Let us know how to use QR codes

In this textbook, you will see many printed QR (Quick Response) codes, such as 

Use your mobile phone or tablet or computer to see interesting lessons, videos, documents, etc. linked to the QR code.

Step	Description
A.	Use Android mobile phone or tablet to view content linked to QR Code:
1.	Click on Play Store on your mobile/ tablet.
2.	In the search bar type DIKSHA .
3.	
	will appear on your screen.
4.	Click Install
5.	After successful download and installation, Click Open
6.	Choose your preferred Language - Click English
7.	Click Continue
8.	Select Student/ Teacher (as the case may be) and Click on Continue
9.	On the top right, click on the QR code scanner icon  and scan a QR code  printed in your book
	OR
	Click on the search icon  and type the code printed below the QR code, in the search bar. (Q)
10.	A list of linked topics is displayed
11.	Click on any link to view the desired content
B.	Use Computer to view content linked to QR code:
1.	Go to https://diksha.gov.in/teelangana
2.	Click on Explore DIKSHA-TELANGANA
3.	Enter the code printed below the QR code in the browser search bar (Q)
4.	A list of linked topics is displayed
5.	Click on any link to view the desired content





IN ANY EMERGENCY



 **DIAL**

1000

TELANGANA POLICE

 www.tspolice.gov.in

  @ **Telangana State Police**





Government of Telangana

Department of Women Development & Child Welfare - Childline Foundation

When abused in or out of school.

To save the children from dangers and problems.



CHILD LINE 1098
NIGHT & DAY
24 HOUR NATIONAL HELPLINE

When the children are denied school and compelled to work.

When the family members or relatives misbehave.

1098 (Ten...Nine...Eight) dial to free service facility.

MATHEMATICS

Class VI
(English Medium)

Published by

The Government of Telangana, Hyderabad

Respect the Law
Get the Rights

Grow by Education
Behave Humbly



© Government of Telangana, Hyderabad.

First Published 2012

*New Impressions 2013, 2014, 2015, 2016, 2017, 2018, 2019, 2020, 2021, 2022, 2023,
2024*

Republished 2025

All rights reserved.

No part of this publication may be reproduced, stored in a retrieval system, or transmitted, in any form or by any means without the prior permission in writing of the publisher, nor be otherwise circulated in any form of binding or cover other than that in which it is published and without a similar condition including this condition being imposed on the subsequent purchaser.

The copy right holder of this book is the Director of School Education, Hyderabad, Telangana.

This Book has been printed on 70 G.S.M. Maplitho
Title Page 200 G.S.M. White Art Card

Government's Gift for Students' Progress 2025-26

Printed in India
at the Telangana Govt. Text Book Press,
Mint Compound, Hyderabad,
Telangana.

— o —

Government of Telangana
Department of School Education



తెలంగాణ తల్లి

Published by the Government of Telangana, Hyderabad.

STATE SONG

1. Jaya jayahe Telangana jananee jayakethanam
Mukkoti gonthukalu okkataina chethanam
Tharatharaala charithagala thallee neerajanam
Padapadaana nee pillalu pranamillina shubha tharunam
Jai Telangana jai jai Telangana
Jai Telangana jai jai Telangana
2. Pampanaku Janmanichi Badhenaku padyamichi
Bheemakaviki Chanubala beejaksharamaina thalli
Haaluni Gaathasapthashathiki vuyaloodina nela
Bruhatkathala Telangana kotilingala kona
Jai Telangana jai jai Telangana
Jai Telangana jai jai Telangana
3. Prajala bhashalo kavya pramaanalu prakatinchina
Telugulo toli prajakavi Palakurki Somanna
Rajyaanne dhikkarinchi Ramulori gudinigatti
kavirajai velige dishala kancharla Gopanna
Jai Telangana jai jai Telangana
Jai Telangana jai jai Telangana
4. Kaalidasa Kaavyalaku bhaashyalanu raasinatti
Mallinaathasoori ma Methukuseema kannu biddu
Dhulikattanelinatti Boudhaniki bhanduvathadu
Dignaguni ganna nela dhikkarama janma hakku
Jai Telangana jai jai Telangana
Jai Telangana jai jai Telangana
5. Potanadi puritigadda Rudramadee veeragadda
Gandara gandadu Komuram Bheemude nee biddu
Kakatiya kalaaprabhala kanthirekha Ramappa
Golukonda Bhaagyanagari goppavelugu Charminaru
Jai Telangana jai jai Telangana
Jai Telangana jai jai Telangana
6. Rachakonda elubadiga ranjillina Recharla
Sarvagna Singa Bhupaluni bangaru bhoomi
Vani naa rani antu ninadinchina kavikularavi
pillalamarri pina veerabhadrudu malo rudrudu
Jai Telangana jai jai Telangana
Jai Telangana jai jai Telangana
7. Sammakalu Saarakkalu Sarvai Paapannalu
Sabbanda varnaala sahasaalu koniyaduthu
Ooroora paatalaina Meerasaabu veeragatha
Dandu nadipe Palamooru Pandugolla Sayanna
Jai Telangana jai jai Telangana
Jai Telangana jai jai Telangana
8. Kavigaayaka vaithaalika kalalaa manjeeralu
Dappu dhamarukamu dakki Sharada swara naadhulu
Pallavulaa chirujallula prathi ullamu ranjillaga
Anunityam nee gaanam Amma neeve maa praanam
Jai Telangana jai jai Telangana
Jai Telangana jai jai Telangana
9. Jaanapada janajeevana jaavaleelu jaaluvaara
Kavi gaayaka vaithaalika kalalaa manjeeraalu
Jaathini jaagruthaparache geethaala jana jaathara
Anunithyam nee gaanam Amma neeve maa praanam
Jai Telangana jai jai Telangana
Jai Telangana jai jai Telangana
10. Badula gudulatho pallela odalu pulakarinchali
virise janavignanam nee keerthini penchali
Tadabadakundaa jagaana thala etthukoni brathuka
oka jaathiga nee santhathi oyamma velagaali
Jai Telangana jai jai Telangana
Jai Telangana jai jai Telangana
11. Siri velugulu jimme Singareni nalla bangaram
Anuvuvuna khanijale nee thanuvuna singaram
Sahajamaina vanasampada sakkanaina puvvula poda
Sirulu pande saramunna maagaaname kada nee yeda
Jai Telangana jai jai Telangana
Jai Telangana jai jai Telangana
12. Godavari krushnammalu thallee ninu thadupangaa
Pachchani maa nelallo pasidi sirulu pandanga
Sukhasaanthula Telangana subhikshanga undaale
Prathi dinamadi Telangana prajala kalalu pandaali
Jai Telangana jai jai Telangana
Jai Telangana jai jai Telangana

- Andhe Sri

NATIONAL ANTHEM

Jana gana mana adhinayaka, jaya he
Bharata bhagya vidhata.
Punjab Sindh Gujarat Maratha
Dravida Utkala Banga
Vindhya Himachala Yamuna Ganga
Uchchhala jaladhi taranga.
Tava shubha name jage,
Tava shubha asisa mage,
Gahe tava jaya gatha,
Jana gana mangaladayaka jaya he
Bharata bhagya vidhata.
Jaya he! jaya he! jaya he!
Jaya jaya jaya, jaya he!!

- Rabindranath Tagore

PLEDGE

“India is my country; all Indians are my brothers and sisters.
I love my country, and I am proud of its rich and varied heritage.
I shall always strive to be worthy of it.
I shall give my parents, teachers and all elders respect,
and treat everyone with courtesy. I shall be kind to animals.
To my country and my people, I pledge my devotion.
In their well-being and prosperity alone, lies my happiness.”

- Pydimarri Venkata Subba Rao



THE CONSTITUTION OF INDIA

Preamble

WE, THE PEOPLE OF INDIA, having solemnly resolved to constitute India into a **SOVEREIGN SOCIALIST SECULAR DEMOCRATIC REPUBLIC** and to secure to all its citizens:

JUSTICE, social, economic and political;

LIBERTY of thought, expression, belief, faith and worship;

EQUALITY of status and of opportunity; and to promote among them all

FRATERNITY assuring the dignity of the individual and the unity and integrity of the Nation;

IN OUR CONSTITUENT ASSEMBLY this twenty-sixth day of November, 1949 do **HEREBY ADOPT, ENACT AND GIVE TO OURSELVES THIS CONSTITUTION.**

FOREWORD

State Curriculum Frame Work (SCF-2011) recommends that childrens' life at schools must be linked to their life outside the school. The Right To Education Act (RTE-2009) perceives that every child who enters the school should acquire the necessary skills prescribed at each level upto the age of 14 years. Academic standards were developed in each subject area accordingly to maintain the quality in education. The syllabi and text books developed on the basis of National Curriculum Frame work 2005 and SCF-2011 signify an attempt to implement this basic idea.

Children after completion of Primary Education enter into the Upper Primary stage. This stage is a crucial link for the children to continue their secondary education. We recognise that, given space, time and freedom, children generate new knowledge by exploring the information passed on to them by the adults. Inculcating creativity and initiating enquiry is possible if we perceive and treat children as participants in learning and not as passive receivers. The children at this stage possess characteristics like curiosity, interest, questioning, reasoning, insisting proof, accepting the challenges etc., Therefore the need for conceptualizing mathematics teaching that allows children to explore concepts as well as develop their own ways of solving problems in a joyful way.

We have begun the process of developing a programme which helps children understand the abstract nature of mathematics while developing in them the ability to construct own concepts. The concepts from the major areas of Mathematics like Number System, Arithmetic, Algebra, Geometry, Mensuration and Statistics are provided at the upper primary stage. Teaching of the topics related to these areas will develop the skills prescribed in academic standards such as problem solving, logical thinking, expressing the facts in mathematical language, representing data in various forms, using mathematics in daily life situations.

The textbooks attempt to enhance this endeavor by giving higher priority and space to opportunities for contemplation and wondering, discussion in small groups and activities required for hands on experience in the form of 'Do This', 'Try This' and 'Projects'. Teachers support is needed in setting of the situations in the classroom. We also tried to include a variety of examples and opportunities for children to set problems. The book attempts to engage the mind of a child actively and provides opportunities to use concepts and develop their own structures rather than struggling with unnecessarily complicated terms and numbers. The chapters are arranged in such a way that they help the Teachers to evaluate every area of learning to comprehend the learning progress of children and in accordance with Continuous Comprehensive Evaluation (CCE). This textbook has been energized with QR (Quick Response) codes to facilitate the students in understanding the concepts clearly.

I wish to thank the national experts, university teachers, research scholars, NGOs, academicians, writers, graphic designers and printers who are instrumental to bring out this textbook in present form. Our special thanks to Faculty of School of Education Tata Institute of Social Sciences (TISS), Hyderabad and Communication Officer, CETE, TISS-Mumbai and Designers identified by SCERT for their technical support in redesigning of the textbooks.

I hope the teachers will make earnest effort to implement the syllabus in its true spirit and to achieve academic standards at the stage.

The process of developing materials is a continuous one and we hope to make this book better. As an organization committed to systematic reform and continuous improvement in quality of its products, SCERT, welcomes comments and suggestions which will enable us to undertake further revision and refinement.

DIRECTOR
SCERT, Hyderabad

CONTENTS

S.No.	Contents	Syllabus to be covered during	Page No
1.	Knowing Our Numbers	June	1 - 15
2.	Whole Numbers	July	16 - 28
3.	Playing with Numbers	July	29 - 48
4.	Basic Geometrical Ideas	August	49 - 60
5.	Measures of Lines and Angles	August	61 - 72
6.	Integers	September	73 - 84
7.	Fractions and Decimals	September, October	85 - 106
8.	Data Handling	October	107 - 118
9.	Introduction to Algebra	November	119 - 130
10.	Perimeter and Area	November, December	131 - 144
11.	Ratio and Proportion	December	145 - 157
12.	Symmetry	January	158 - 167
13.	Practical Geometry	February	168 - 177
14.	Understanding 3D and 2D Shapes	February	178 - 185
	Revision	March	



Knowing our Numbers

1

1.1 INTRODUCTION

Latha and Uma took admission in class VI. On the first day at the school, their maths teacher discussed the population of India, population of the State, population of the District as per the recent census. Uma did not understand some of the numbers discussed by the teacher. While coming back home, Uma asked Latha about the population of their village.

Uma : Do you know the population of our village?

Latha : Yes, I know

Uma : How?

Latha : I have seen it on the wall of the panchayat office.

Uma : What particulars are written on the wall?

Latha : All information regarding our village especially population of our village, number of men, women and children, number of houses, pucca, kuccha etc.

Uma : Shall we visit the place now?

Latha : Sure.

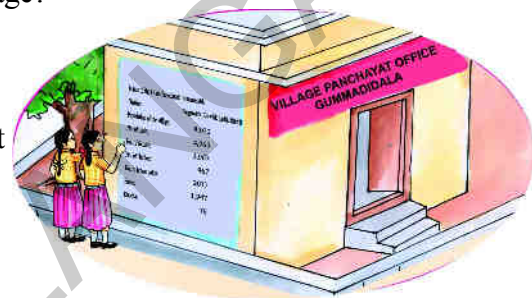

Both of them visited the panchayat office on their way back home and observed the particulars on the wall

Name of the Gram Panchayat	:	Gummadidala
District	:	Sangareddy
Population of the village	:	8,032
No. of men	:	4,065
No. of women	:	3,967
No. of children	:	967
No. of house holds	:	2017
No. of Pucca houses	:	1,947
No. of Kuccha houses	:	76

Uma read the particulars on the wall and understood the figures. She also asked Latha about lakhs and crores, as the teacher had discussed the population in lakhs and crores in the class. Do you have any idea about lakhs and crores? Discuss with your friends.

We have discussed numbers upto thousands in earlier classes. We use numbers in many ways. We compare them, arrange them in increasing and decreasing orders, add and subtract them.

Can you give any five situations where we use numbers in thousands?

For example a television costs ₹12,500.

Let us revise the numbers learnt in previous classes to understand and enjoy about larger numbers.

1.2 ESTIMATING AND COMPARING NUMBERS

Identify the greatest and the smallest among the following numbers.

S.No.	Numbers	the greatest number	the smallest number
1.	3845, 485, 34, 13845	13845	34
2.	856, 1459, 35851, 23
3.	585, 9535, 678, 44
4.	39, 748, 19651, 7850

We can identify them easily by simply counting the digits in the numbers. Generally the numbers having five digits are greater than numbers having two digits.

Now ask your friend to compare 51845 and 41964. which is greater? This is also easy as the digit in ten thousands place is 5 in 51845 and 4 in 41964. So $51845 > 41964$

Now try to say which is greater, 58672 or 57875? both numbers contain the same number of digits. As 5 is in ten thousands place in both numbers, we compare the next place i.e. thousands. As $8 > 7$. So 58672 is bigger. i.e $58672 > 57875$.

If the digits in the thousands place are also same, what will you do? We move to the hundreds place to compare, then tens place and finally units place.



EXERCISE - 1.1

- Which is the greatest and the smallest among the following numbers?
 - 15432, 15892, 15370, 15524
 - 25073, 25289, 25800, 25623
 - 44687, 44645, 44670, 44602
 - 75671, 75635, 75641, 75610
 - 34895, 34891, 34899, 34893
- Write the numbers in ascending (increasing) order:
 - 375, 1475, 15951, 4713
 - 9347, 19035, 22570, 12300

3. Write the numbers in descending (decreasing) order:
 - i. 1876, 89715, 45321, 89254
 - ii. 3000, 8700, 3900, 18500
4. Compare the numbers by placing appropriate symbol (< or >) in the space given:
 - i. 3854 15200
 - ii. 4895 4864
 - iii. 99454 99445
 - iv. 14500 14499
5. Write the numbers in words:
 - i. 72642 =
 - ii. 55345 =
 - iii. 66600 =
 - iv. 30301 =
6. Write the numbers in figures:
 - i. Forty thousand two hundred seventy =
 - ii. Fourteen thousand sixty four =
 - iii. Nine thousand seven hundred =
 - iv. Sixty thousand =
7. Form four digit numbers with the digits 4, 0, 3, 7 and find which is the greatest and the smallest among them?
8. Write the following numbers.
 - i. the smallest four digit number
 - ii. the greatest four digit number
 - iii. the smallest five digit number
 - iv. the greatest five digit number

1.3 ESTIMATION AND ROUNDING OFF NUMBERS

We use numbers in our daily life situations, such as:

- Nearly 25,000 people visited Salarjung museum in the month of November.
- In our State, this year approximately 9 lakh students will appear for S.S.C. board examination.

The words 'nearly', 'approximately', 'roughly' do not show the exact number of people, students or weight. Writing the numbers to the nearest like this is considered as one kind of estimation. Infact 25,000 may be 24,975 or 25,045. i.e. it may be a little less or more, but not exact.

Estimation is also helpful in identifying, rounding off the numbers. We usually round off the numbers to the nearest 10's (Tens), 100's (Hundreds), 1000's (Thousands), 10000's (Ten Thousands)... etc.

Observe the procedure: **Rounding off the numbers to the nearest tens**

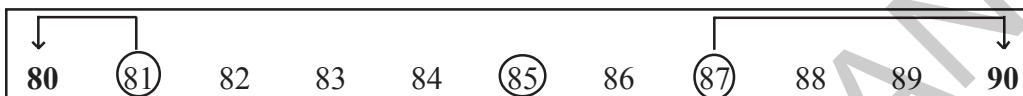

- ◆ In the above numbers, the greatest number is 90, the smallest number is 80 and the middle number is 85.
- ◆ 81 is nearer to 80 than 90, so 81 will be rounded off to 80.
- ◆ 87 is nearer to 90 than 80, so 87 will be rounded off to 90.
- ◆ 85 is at equal distance from 80 and 90 but by convention it is rounded off to 90.

Rounding off the numbers to the nearest hundreds:



- ◆ In this the smallest number is 200, the greatest number is 300 and the middle number is 250.
- ◆ 220 is nearer to 200 than 300, so 220 is rounded off to 200.
- ◆ 280 is nearer to 300 than 200, so it is rounded off to 300.
- ◆ What is the rounding off number for 250? Why?



DO THIS

Round off these numbers as directed:

1. 48, 62, 81, 94, 27 to their nearest tens
2. 128, 275, 312, 695, 199 to their nearest hundreds.
3. 7452, 8115, 3066, 7119, 9600 to their nearest thousands.

THINK, DISCUSS AND WRITE

Discuss with your friends about rounding off numbers for ten thousands place.



1.4 REVISION OF PLACE VALUE

You have already learnt how to expand a number using place value. Recall how you expand a two digit, three digit, four digit and five digit number:

1. Expand 64

Tens	Ones
6	4

$$= (6 \times 10) + (4 \times 1)$$
$$= 60 + 4$$

2. Expand 325

Hundreds	Tens	Ones
3	2	5

$$= (3 \times 100) + (2 \times 10) + (5 \times 1)$$
$$= 300 + 20 + 5$$

3. Expand 5078

Thousands	Hundreds	Tens	Ones
5	0	7	8

$$= (5 \times 1000) + (0 \times 100) + (7 \times 10) + (8 \times 1) = 5000 + 0 + 70 + 8$$
$$= 5000 + 70 + 8$$

4. Expand 29500

Ten Thousands	Thousands	Hundreds	Tens	Ones
2	9	5	0	0

$$= (2 \times 10000) + (9 \times 1000) + (5 \times 100) + (0 \times 10) + (0 \times 1)$$
$$= 20000 + 9000 + 500 + 0 + 0$$
$$= 20000 + 9000 + 500$$



DO THIS

Now expand the numbers in the table as given in the example:

Number	Expansion	Expanded form
21504	$(2 \times 10000) + (1 \times 1000) + (5 \times 100) + (0 \times 10) + (4 \times 1)$	$20000 + 1000 + 500 + 4$
38400		
77888		
20050		
41501		



EXERCISE - 1.2

- Round off the following numbers to the nearest tens:
 - 89
 - 415
 - 3951
 - 4409
- Round off the following numbers to the nearest hundreds:
 - 695
 - 36152
 - 13648
 - 93618
- Round off the following numbers to the nearest thousands:
 - 3415
 - 70124
 - 8765
 - 4001
- Write the numbers in short form:
 - $3000 + 400 + 7$
 - $10000 + 2000 + 300 + 50 + 1$
 - $30000 + 500 + 20 + 5$
 - $90000 + 9000 + 900 + 90 + 9$
- Write the expanded form of the numbers:
 - 4348
 - 30214
 - 22222
 - 75025

1.5 INTRODUCTION TO LARGE NUMBERS

The greatest five digit number is 99,999. Now, we add 1 to it.

$$99,999 + 1 = 1,00,000$$

This number is **one lakh**. One lakh comes after 99,999.

Now can you say how many tens are there in one lakh?

how many hundreds are there in one lakh?

how many thousands are there in one lakh?

Now, let us take the number 3,15,645. Its expanded form is :

$$\begin{aligned} 3,15,645 &= (3 \times 100000) + (1 \times 10000) + (5 \times 1000) + (6 \times 100) + (4 \times 10) + (5 \times 1) \\ &= 300000 + 10000 + 5000 + 600 + 40 + 5 \end{aligned}$$

Observe the table.

3	1	5	6	4	5
Lakhs	Ten thousands	Thousands	Hundreds	Tens	Ones

This number has 5 in ones place, 4 in tens place, 6 in hundreds place, 5 in thousands place, 1 in ten thousands place and 3 at lakhs place. Now we read the number as three lakh fifteen thousand six hundred and forty five.

Read and expand the numbers as shown below.

Number	Expanded form	Read as
5,00,000	5×100000	Five lakh
4,50,000	$4 \times 100000 + 5 \times 10000$	Four lakh fifty thousand
4,57,000		
3,05,400		
3,09,390		
2,00,035		

Write a few more 6 digit numbers and ask your friend to read and expand them.

What number would you get if all digits are 9s in a 6-digit number?

Can you call it the greatest 6-digit number? Why?

Now if we add '1' to this number, what would we get?

$$9,99,999 + 1 = 10,00,000$$

It is called **ten lakh**.

Is it the smallest 7-digit number?

Now observe the following pattern and complete it.

$$9 + 1 = 10$$

$$99 + 1 = 100$$

$$999 + 1 = 1000$$

$$9999 + 1 = \dots\dots\dots$$

$$99999 + 1 = \dots\dots\dots$$

$$999999 + 1 = \dots\dots\dots$$

$$9999999 + 1 = 1,00,00,000$$

Add one to the greatest 7-digit number. You get the smallest 8-digit number which is called **one crore**.

How will you get the greatest 8 digit number?

We come across large numbers in many different situations. For example, area of our country is 32, 87, 263 square km., population of our state 8,46,65,533. Similarly cost of school building, agricultural production, distance between the planets, multiplication of 3 digit numbers with 3 or more digit numbers, we obtain large numbers.

By learning these large numbers, do you think Uma can understand the numbers taught by her teacher in the classroom?



TRY THESE

1. Give any five examples using daily life situations where the number of things counted would be more than 6-digits.
2. Write the smallest and the greatest of all two digit, three digit, four digit, five digit, six digit, seven digit and eight digit numbers.

1.5.1 Place value of larger numbers

Read the following numbers:

- a) 25240 b) 130407 c) 4504155 d) 12200320

Did you find it difficult to read the number in crores, lakhs and thousands?

Now read the following numbers.

- a) 25,240 b) 1,30,407 c) 45,04,155 d) 1,22,00,320

Comparitively is it easier to read the numbers using commas ?

Use of 'comma' helps us in reading and writing of large numbers.

There are some indicators useful in writing the expansion of numbers. For example, Radha is expanding a number. She identifies the digits in ones place, tens place and hundreds place in 367, by writing them under O, T and H as shown in the table.

H	T	O	Expansion
3	6	7	$3 \times 100 + 6 \times 10 + 7 \times 1$

Similarly for 1,729

Th	H	T	O	Expansion
1	7	2	9	$1 \times 1000 + 7 \times 100 + 2 \times 10 + 9 \times 1$

One can extend this idea to numbers upto lakhs and crores as shown in the following table:

Places	Crores		Lakhs		Thousands		Hund- reds (H)	Tens (T)	Ones (O)
	Ten Crores (T. Cr)	Crores (Cr)	Ten Lakhs (T. La)	Lakhs (La)	Ten Thou- sands (T.Th.)	Thou- sands (Th.)			
Number	10,00,00,000	1,00,00,000	10,00,000	1,00,000	10,000	1,000	100	10	1
No. of Digits	9	8	7	6	5	4	3	2	1

1 crore = 100 lakhs

= 10,000 thousands

1 lakh = 100 thousands

= 1000 hundreds

Now let us write the large numbers using the place value chart and read the number as given below:

Number	T.Cr.	Cr.	T.La	La	T.Th.	Th.	H	T	O	Read as
41430495	-	4	1	4	3	0	4	9	5	Four crore fourteen lakh thirty thousand four hundred ninety five
304512031										
241800240										
69697100										
100091409										

Think of five more large numbers and write them. Can you write the expanded form of these numbers as shown below?

Expansion of 12735045

$$1,27,35,045 = 1 \times 1,00,00,000 + 2 \times 10,00,000 + 7 \times 1,000,00 + 3 \times 10,000 + 5 \times 1,000 + 0 \times 100 + 4 \times 10 + 5 \times 1$$



DO THIS

Expand the numbers using commas.

i. 999999999

ii. 34530678

iii. 510010051

1.5.2 Usage of commas

In our Indian system of numeration we use ones, tens, hundreds, thousands, lakhs and crores. Commas are used to mark thousands, lakhs and crores. The first comma comes after hundred place (i.e. three digits from the right) and marks thousands 74517,500. The second comma comes two digits later (i.e. five digits from the right) 745,17,500. It comes after ten thousands place and marks lakh. The third comma comes after another two digits. (i.e. seven digits from the right) 7,45,17,500. It comes after ten lakhs place and marks crore. Commas help us in reading and writing large numbers easily.

For example, Seven crore forty five lakh seventeen thousand and five hundred can be written as,

7, 45, 17, 500.

Similarly we can easily read this number which is separated by commas as 45,30,14,252 (Forty five crore thirty lakh fourteen thousand two hundred fifty two).



DO THIS

Read these numbers and write in words.

a) 5,06,45,075

b) 12,36,99,140

c) 2,50,00,350



EXERCISE - 1.3

- Write the numbers using commas according to place values.**
 - 11245670
 - 22402151
 - 30608712
 - 190308020
- Write the numbers in words.**
 - 34,025
 - 7,09,115
 - 47,60,00,317
 - 6,18,07,000
- Write the number in figures.**
 - Four lakh fifty seven thousand four hundred.
 - Sixty lakh two thousand and seven hundred seventy five.
 - Two crore fifty lakh forty thousand three hundred and three.
 - Sixty crore sixty lakh sixty thousand six hundred.
- Write the numbers in expanded form.**
 - 6,40,156
 - 63,20,500
 - 1,25,30,275
 - 75,80,19,202
- Write the following numbers in short form (standard notation):
 - $50,00,000 + 4,00,000 + 20,000 + 8,000 + 500 + 20 + 4$
 - $6,00,00,000 + 40,00,000 + 3,00,000 + 20,000 + 500 + 1$
 - $3,00,00,000 + 3,00,000 + 7,000 + 800 + 80 + 1$
 - $7,00,00,000 + 70,00,000 + 7000 + 70$.
- Which is larger between each of these two? Use greater than symbol ($>$) and write.**
 - 4,67,612 or 18,71,964
 - 14,35,10,300 or 14,25,10,300
- Which is smaller between each of these two? Use less than symbol ($<$) and write.**
 - 2,00,015 or 99,999
 - 13,50,050 or 13,49,785
- Write any ten numbers with digits 5 in crores place, 2 in lakhs place, 1 in ten thousands place, 6 in tens place and 3 in ones place. (keep any digits in the remaining places)**

1.6 INTERNATIONAL SYSTEM OF NUMERATION

The numbers in which we read and write in our country are different from that of many other countries. We use lakhs for 6-digit number, ten lakhs for 7-digit numbers and then crores and ten crores etc. In the International system of numeration, we use ones, tens, hundreds, thousands, ten thousands, hundred thousands and then millions.

One million is a thousand thousands or ten lakhs. Commas are used to mark thousands and millions. Comma comes after every three digits from the right.

Suppose the number is 45690255

Indian system of numeration	International system of numeration
4,56,90,255	45,690,255
Four crore fifty six lakhs ninety thousand two hundred and fifty five.	Forty five million six hundred ninety thousand two hundred fifty five.

Have you noticed that there is no change of numeration upto hundreds place?

What else have you observed?

Let us compare the places in both the systems for better understanding:

Indian System	H.Cr.	T.Cr.	Cr.	T.La	La	Ten Th.	Thou-sand	Hund.	Tens	Ones
International System	Billion	Hund. Million	Ten Million	Million	Hun. Th.	Ten Th.	Thous.	Hund	Tens	Ones

From the above table, the relation between these systems can be understood as follows:

10 lakhs	=	1 million
1 crore	=	10 million
10 crore	=	100 million
100 crore	=	1 billion



EXERCISE - 1.4

- Write the numbers using commas according to International system of numeration.
 - 97645315
 - 20048421
 - 476356
 - 9490026834
- Collect the mobile numbers of your friends and other family members. Write them using commas and read them in International system.
- Write the numbers in words in both Indian and International system:
 - 123115027
 - 89643092
- Read the number carefully and answer the following:
302,179,468
 - The digit in millions place
 - The digit in hundreds place
 - The digit in ten millions place

1.7 LARGE NUMBERS USED IN DAILY LIFE SITUATIONS

We know that we use meter (m) as unit of length, kilogram (kg) as a unit of weight and litre (l) as a unit of volume of liquids and second (s) as a unit of time.

For example, in the case of length or distance, we use centimeter for measuring the length of a pencil as it is small, meter for measuring length of a cloth and kilometer (km) for measuring distance between two places. But for measuring the thickness of a paper, even centimeter is too big. So we use millimeter (mm) in this case.

Since there is a relationship between all of them we need to know about this conversion and convenient usage.

10 millimeters	=	1 centimeter
100 centimeters	=	1 meter
1000 meters	=	1 kilometer

How would you calculate the number of millimeters in 1 kilometer?

$$\begin{aligned}1 \text{ km} &= 1000\text{m} \\ &= 1000 \times 100 \text{ cm} \\ &= 1000 \times 100 \times 10 \text{ mm} \\ &= 10,00,000 \text{ mm}\end{aligned}$$

In the same way we buy rice or wheat in kilograms. But items like spices, chillipowder, haldi etc. which we do not need in large quantities, are bought in grams (g).

$$1000 \text{ g.} = 1 \text{ kg}$$

Can you calculate the number of milli grams in 1 kg?

A bucket normally holds 20 litres of water. But some times we need a smaller unit, the milliliters. A bottle of hair oil, painting colour in milliliters (ml) and oil tankers, water in reservoirs are marked with kilolitres (kl)

$$1000 \text{ litres} = 1 \text{ kilo litre}$$

How many milli litres will make 1 killo litre?



TRY THESE

1. Name four important towns in your district. Note the distance between them in km. Express these in centimeters and millimeters.
2. Can you tell where we use milligrams?
3. A box contains 1,00,000 tablets (medicine) each weighing 20 mg. What is the weight of all the tablets in the box in both grams and kilograms?
4. A petrol tanker contains 20,000 litres of petrol. Express the quantity of petrol in kilolitres and millilitres.

Let us understand some examples using large numbers in daily life.

Example-1. Tendulkar is a famous cricket player. He has so far scored 15,030 runs in test matches and 18,111 runs in one day cricket. What is the total number of runs scored by him in both formats?

Solution:

Runs scored in Test matches by Tendulkar	=	15,030
Runs scored in One day matches	=	18,111
Total number of runs	=	<u>33,141</u>

Example-2. A newspaper is published everyday. It contains 16 pages. Every day 15,020 copies are printed. How many pages are printed every day?

Solution:

Number of copies printed every day	=	15,020
Number of pages in each copy	=	16
Number of pages in 15,020 copies	=	$15,020 \times 16$ pages.

Try to estimate the total number of pages. It must be more than 2,00,000 pages.

Total number of pages printed = $15,020 \times 16 = 2,40,320$

So, every day 2,40,320 pages are printed.

Example-3. A hotel has 15 litres milk. 25ml of milk is required to prepare a cup of tea. How many cups of tea can be made with the milk.

Solution:

Quantity of milk in the hotel	=	15 litres
	=	15×1000 ml
	=	15000 ml

Since 25ml. of milk is required for each cup of tea

number of cups of tea that can be made with the milk	=	$15000 \div 25$
	=	600 cups



EXERCISE - 1.5

1. The number of people who visited during commonwealth games in New Delhi for the first four days was recorded as 15,290; 14,181; 14,235 and 10,578. Find the total number of people visited in these four days?
2. In Lok Sabha election, the elected candidate got 5,87,500 votes and defeated candidate got 3,52,768. By how many votes did the winner win the election?
3. Write the greatest and smallest 5-digit number formed by the digits 5, 3, 4, 0 and 7 and find their difference? (use the digits once only)
4. A bicycle industry makes 3,125 bicycles each day. Find the total number of bicycles manufactured in the month of July?
5. A helicopter covers 600 km. in 1 hour. How much distance will it cover in 4 hours?

- The total weight of 5 biscuit packets of same size is 8kg 400 grams. What is the weight of each packet?
- Everyday Gayatri walks both the ways to attend the school. The distance between the school and her house is 1 km 875 m. Find the total distance she walked in 6 days?
- The cloth required to make a shirt of school uniform for each boy is 1 m 80 cm. How many shirts can tailor stitch using 40m. of cloth? How much cloth will be left?
- The rate of petrol is ₹60 per litre. A petrol bunk sells 750 litres of petrol on a day. How much money do they get at the end of the day?

THINK, DISCUSS AND WRITE

- You live in Ahmedabad and you travelled 400 m by bus to reach the nearest station. Then you take a train to reach Gandhi Nagar which is 15 km. away. Then you take a cab to reach your aunt's house which is 18 km. away.
 - How much distance did you travel to reach your aunt's house?
 - If you travel for 7 days like this how much distance would you travel?
- Every child in your school bring a water bottle containing 2 litres of water. If all the water is poured into a container which has 2 kilo litre capacity of water it was found that it needed 600 litre more to be filled. How many children poured water bottles in the container?



WHAT HAVE WE DISCUSSED?

- Given two numbers, one with more digits is the greater number. If the number of digits in two given numbers is the same, that number is greater, which has a greater leftmost digit. If this digit also happens to be the same, we look at the next digits and so on.
- In forming numbers from given digits, we should be careful to see if the conditions under which the numbers are to be formed are satisfied. Thus, to form the greatest four digit number from 7, 8, 3, 5 without repeating a single digit, we need to use all four digits, the greatest number can have only 8 as the leftmost digit.
- The smallest four digit number is 1000 (one thousand). It follows the largest three digit number 999. Similarly, the smallest five digit number is 10,000. It is ten thousand and follows the largest four digit number 9999.



4. Use of commas helps in reading and writing large numbers. In the Indian system of numeration we have commas after 3 digits starting from the right and thereafter every 2 digits. The commas after 3rd, 5th and 7th digits to separate thousand, lakh and crore respectively. In the International system of numeration commas are placed after every 3 digits starting from the right. The commas after 3rd and 6th digits to separate thousand and million respectively.
5. Large numbers are needed in many ways in daily life. For example, for counting number of students in a district, number of people in a village or town, money paid or received in large transaction (paying and selling), in measuring large distances say between various cities in a country or in the world and so on.
6. Remember that kilo means 1000, Centi means 100th part and milli means 1000 part. Thus, 1 kilometre = 1000 metres, 1 metre = 100 centimetres or 1000 millimetres etc.
7. There are a number of situations in which we do not need the exact quantity but need only a reasonable guess or an estimate. For example, while stating how many spectators watched a particular International hockey match, we state the approximate number, say 51,000, we do not need to state the exact number.
8. Estimation involves approximating a quantity to an accuracy required. Thus, 4,117 may be approximated to 4,100 or to 4,000, i.e. to the nearest hundred or to the nearest thousand depending on our need.
9. In number of situations, we have to estimate the outcome of number operations. This is done by rounding off the numbers involved and getting a quick, rough answer.
10. Use of numbers in Indo-Arabic system and International system.

Srinivasa Ramanujan (India)

1887 - 1920

He worked on the number Theory. He is the first Indian elected to the fellow of Royal Society (England). 1729 is the Ramanujan's Number. Mathematics Day is celebrated on 22nd December every year on his birth day.



A Postal Stamp was released by the Government of India in memory of Ramanujan in 2011. Govt. of India Declared 2012 as Maths year.



Whole Numbers

2

2.1 INTRODUCTION

In our previous class, we learnt about counting things. While counting things, we need numbers 1, 2, 3, to count. These numbers are called natural numbers. We express the set of natural numbers in the form of $N = \{1, 2, 3, 4, \dots\}$

While learning about natural numbers, we experienced that if we add '1' to any natural number, we get the next natural number. For example, if we add '1' to '16', then we get the number 17 which is again a natural number. In the same way if we deduct '1' from any natural number, generally we get a natural number. For example if we deduct '1' from a natural number 25, the result is 24, which is a natural number. Is this true if 1 is deducted from 1?

The next number of any natural number is called its successor and the number just before a number is called the predecessor.

For example, the successor of 9 is 10
and the predecessor of 9 is 8.

Now fill the following table with the successor and predecessor of the numbers provided:

S.No.	Natural number	Predecessor	Successor
1.	13		
2.	237		
3.	999		
4.	26		
5	9		
6	1		

Discuss with your friends

1. Which natural number has no successor?
2. Which natural number has no predecessor?

2.2 WHOLE NUMBERS

You might have come to know that the number '1' has no predecessor in natural numbers. We include zero to the collection of natural numbers. The natural numbers along with the zero form the collection of Whole numbers.

Whole numbers are represented as follows:

$$W = \{0, 1, 2, 3, \dots\}$$



Do This

1. Which is the smallest whole number?

THINK, DISCUSS AND WRITE

1. Are all natural numbers whole numbers?
2. Are all whole numbers natural numbers?



2.3 REPRESENTATION OF WHOLE NUMBERS ON NUMBER LINE

Draw a line. Mark a point on it. Label it as '0'. Mark as many points as you like on the line at equal distance to the right of 0. Label the points as 1, 2, 3, 4, respectively. The distance between any two consecutive points is the unit distance. You can go to any whole number on the right.

The number line for whole numbers is:

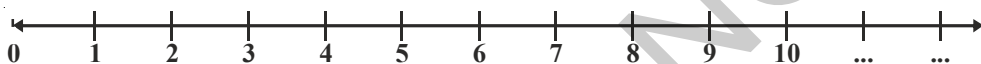

On the number line given above you know that the successor of any number will lie to the right of that number. For example, the successor of 3 is 4. 4 is greater than 3 and lies on the right side of number 3.

Now can we say that all the numbers that lie on the right of that number are greater than the number?

Discuss with your friends and fill the table.

S.No.	Number	Position on number line	Relation between numbers
1.	12, 8	12 lies on the right of 8	$12 > 8$
2.	12, 16		
3.	236, 210		
4.	1182, 9521		
5.	10046, 10960		

Addition on number line

Addition of whole numbers can be represented on number line. In the line given below, the addition of 2 and 3 is shown as below.

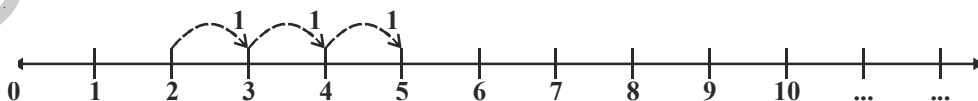

Start from 2, we add 3 to two. We make 3 jumps to the right on the number line, as shown above. We will reach at 5.

$$\text{So, } 2 + 3 = 5$$

So whenever we add two numbers we move on the number line towards right starting

Subtraction on the Number Line

Now consider $6 - 2$.

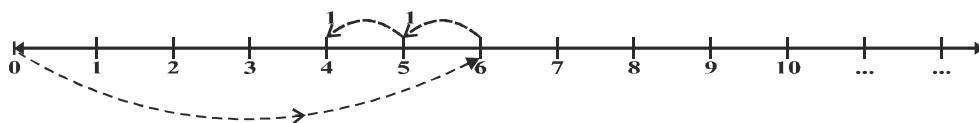

Start from 6. Since we subtract 2 from 6, we take 2 steps to the left on the number line, as shown above. We reach 4. So, $6 - 2 = 4$. Thus moving towards left means subtraction.



DO THIS

Show these on number line:

1. $5 + 3$

2. $5 - 3$

3. $3 + 5$

4. $10 + 1$

Multiplication on the Number Line

Let us now consider the multiplication of the whole numbers on the number line. Let us find 4×2 . We know that 4×2 means taking 2 steps four times. 4×2 means four jumps towards right, each of 2 steps.

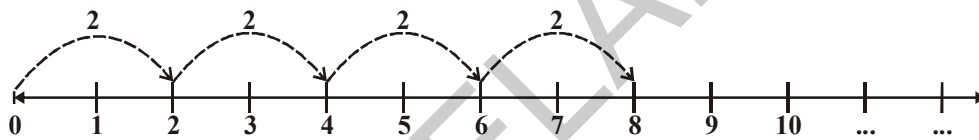

Start from 0, move 2 units to the right each time, making 4 such moves. We will reach 8. So, $4 \times 2 = 8$



TRY THESE

Find the following by using number line:

1. What number should be deducted from 8 to get 5?
2. What number should be deducted from 6 to get 1?
3. What number should be added to 6 to get 8?
4. How many 6 are needed to get 30?

Raju and Gayatri together made a number line and played a game on it.

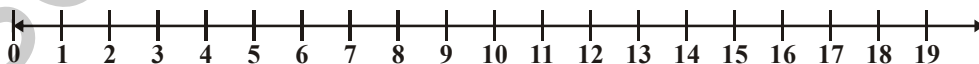

Raju asked "Gayatri, where will you reach if you jump thrice, taking leaps of 3, 8 and 5 starting from zero." Gayatri said 'the first leap will take me to 3 and then from there I will reach 11 in the second step and another five steps from there to 16.

Do you think Gayatri described correctly "where would she reach?" Draw Gayatri's steps.

Play this game using addition and subtraction on this number line with your friend.



EXERCISE - 2.1

- Which of the statements are true (T) and which are false (F). Correct the false statements.
 - There is a natural number that has no predecessor.
 - Zero is the smallest whole number.
 - All whole numbers are natural numbers.
 - On a number line, the whole number which lies right side of another whole number is greater.
 - A whole number on the left of another number on the number line, is greater.
 - We can't show the smallest whole number on the number line.
 - We can show the greatest whole number on the number line.
- How many whole numbers are there in between 27 and 46?
- Find the following using number line.
 - $6 + 7 + 7$
 - $18 - 9$
 - 5×3
- In each pair, state which whole number on the number line is on the right of the other number.
 - 895 ; 239
 - 1001 ; 10001
 - 10015678 ; 284013
- Mark the smallest whole number on the number line.
- Choose the appropriate symbol from $<$ or $>$
 - 8 7
 - 5 2
 - 0 1
 - 10 5
- Place the successor of 11, predecessor of 5 on the number line.

2.4 PROPERTIES OF WHOLE NUMBERS

Studying the properties of whole numbers help us to understand numbers better. Let us look at some of the properties.

Take any two whole numbers and add them. Is the result a whole number?

Think of some more examples and check.

Your additions may be like this:

$$2 + 3 = 5, \text{ a whole number}$$

$$0 + 7 = 7, \text{ a whole number}$$

$$20 + 51 = 71, \text{ a whole number}$$

$$0 + 1 = 1, \text{ a whole number}$$

$$0 + 0 = 0, \text{ a whole number}$$

Here, we observe that the sum of any two whole numbers is always a whole number.

Can you find any pair of whole numbers, which when added will not give a whole number? We see that no such pair exists and the collection of whole numbers are closed under addition. This property is known as the closure property of addition for whole numbers.

Let us check whether the collection of whole numbers is also closed under multiplication. Try with 5 examples.

Your multiplications may be like this:

5	×	6	=	30, a whole number
11	×	0	=	0, a whole number
16	×	5	=	80, a whole number
10	×	100	=	1000, a whole number
7	×	16	=	112, a whole number

The product of any two whole numbers is found to be a whole number too. Hence, we say that the collection of whole numbers is closed under multiplication.

We can say that whole numbers are closed under addition and multiplication.

THINK, DISCUSS AND WRITE

- Are the whole numbers closed under subtraction?

Observe the following and fill up the blanks.

7	-	5	=	2, a whole number
5	-	7	=	-2, not a whole number
.....	-	=
.....	-	=

Take as many examples as possible and check.

- Are the whole numbers closed under division?

Now observe this table:

6	÷	3	=	2, a whole number
5	÷	2	=	$\frac{5}{2}$ is not a whole number
.....	÷	=
.....	÷	=

Confirm it by taking a few more examples.

Division by Zero

Let us find $6 \div 2$

6 Divided by 2 means, we subtract 2 from 6 repeatedly i.e. we subtract 2 from 6 again and again till we get zero.

$$6 - 2 = 4 \quad \text{once}$$

$$4 - 2 = 2 \quad \text{twice}$$

$$2 - 2 = 0 \quad \text{thrice}$$

$$\text{So, } 6 \div 2 = 3$$

Let us consider $3 \div 0$,

Here we have to subtract zero again and again from 3

$$3 - 0 = 3 \quad \text{once}$$

$$3 - 0 = 3 \quad \text{twice}$$

$$3 - 0 = 3 \quad \text{thrice and so on.....}$$

Will this ever stop? No. So, $3 \div 0$ is not a number that we can reach.

So division of a whole number by 0 does not give a known number as answer.

i.e. division by zero is not defined.

Do This

1. Find out $12 \div 3$ and $42 \div 7$
2. What would $6 \div 0$ and $9 \div 0$ be equal to?

Commutativity of whole numbers

Observe the following additions;

$$2 + 3 = 5; \quad 3 + 2 = 5$$

We see in both cases that we get 5. Look at this

$$7 + 8 = 15; \quad 8 + 7 = 15$$

We find that $7 + 8$ and $8 + 7$ are also equal.

Here, the sum is same, though the order of addition of a pair of whole numbers is changed.

Check it for few more examples, $10 + 11$, $25 + 10$.

Thus it is clear that we can add two whole numbers in any order. We say that addition is commutative for whole numbers.

Observe the following figure:

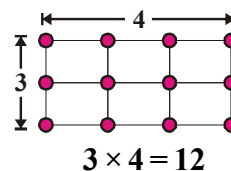
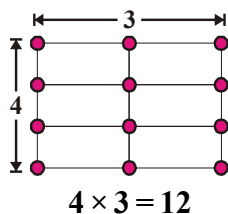

We observe that, the product is same, though the order of multiplication of two whole numbers is changed.

Check it for few more examples of whole numbers like 5×6 , 6×5 and 9×7 , 7×9 etc. Do you get these to be equal too?

Thus, addition and multiplication are commutative for whole numbers.



TRY THESE

Take a few examples and check whether -

1. Subtraction is commutative for whole numbers or not?
2. Division is commutative for whole numbers or not?

Associativity of addition and multiplication

Observe the following:

i. $(3 + 4) + 5 = 7 + 5 = 12$ ii. $3 + (4 + 5) = 3 + 9 = 12$

So, $(3 + 4) + 5 = 3 + (4 + 5)$

In (i) we add 3 and 4 first and then add 5 to the sum and in (ii) we add 4 and 5 first, and then add the sum to 3. But the result is same.

This is called associative property of addition for whole numbers. Create 10 more examples and check it for them. Could you find any example where the sums are not identical?

Observe the following:

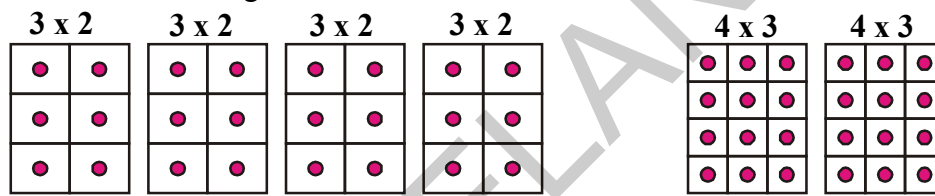

$4 \times (3 \times 2) = \text{four times } (3 \times 2)$

Fig. (a)

$2 \times (4 \times 3) = \text{twice of } (4 \times 3)$

Fig. (b)

Count the number of blocks in fig. (a), and in fig. (b). What do you get? The number of blocks is the same in fig. (a) we have 3×2 blocks in each box. So the total number of blocks is $4 \times (3 \times 2) = 24$

In fig. (b) each box has 4×3 blocks. So the total number of blocks is $2 \times (4 \times 3) = 24$

Thus, $4 \times (3 \times 2) = 2 \times (4 \times 3)$

In multiplication also, we see that the result is same, whichever order of multiplication you follow, the result is the same.

This is associative property for multiplication of whole numbers.

We see that addition and multiplication are associative over whole numbers.



DO THIS

Verify the following:

i. $(5 \times 6) \times 2 = 5 \times (6 \times 2)$

ii. $(3 \times 7) \times 5 = 3 \times (7 \times 5)$

Example-1. Find $196 + 57 + 4$.

Solution:

$$\begin{aligned} & 196 + (57 + 4) \\ & = 196 + (4 + 57) \text{ [Commutative property]} \\ & = (196 + 4) + 57 \text{ [Associative property]} \\ & = 200 + 57 = 257 \end{aligned}$$

Here we used a combination of commutative and associative properties for addition.

Do you think using the commutative and associative properties made the calculations easier?

Example-2. Find $5 \times 9 \times 2 \times 2 \times 3 \times 5$

Solution:

$$\begin{aligned} & 5 \times 9 \times 2 \times 2 \times 3 \times 5 \\ & = 5 \times 2 \times 9 \times 2 \times 5 \times 3 \quad \text{[Commutative property]} \\ & = (5 \times 2) \times 9 \times (2 \times 5) \times 3 \quad \text{[Associative property]} \\ & = 10 \times 9 \times 10 \times 3 \\ & = 90 \times 30 = 2700 \end{aligned}$$

Here we used a combination of commutative and associative properties for multiplication.

Do you think using the commutative and associative properties made the calculations easier?



DO THIS

Use the commutative and associative properties to simplify the following:

- i. $319 + 69 + 81$ ii. $431 + 37 + 69 + 63$
iii. $2 \times (71 \times 5)$ iv. $50 \times 17 \times 2$

THINK, DISCUSS AND WRITE

Is $(16 \div 4) \div 2 = 16 \div (4 \div 2)$?

Does the associative property for division hold for the set of whole numbers?

Check if the property holds for subtraction of whole numbers too.

Give 5 examples each for substantiate your answer.



Observe the following

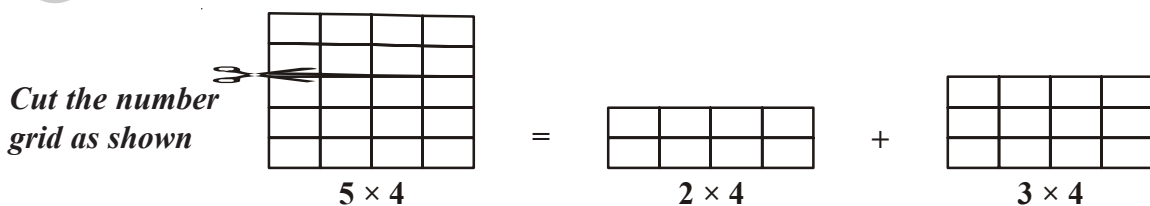

The grid paper 5×4 has been divided into two pieces 2×4 and 3×4

Thus, $5 \times 4 = (2 \times 4) + (3 \times 4)$
 $= 8 + 12 = 20$

also since $5 = 2 + 3$, we have

$$5 \times 4 = (2 + 3) \times 4 \text{ Thus we can say } (2 + 3) \times 4 = (2 \times 4) + (3 \times 4)$$

In the same way, $(5 + 6) \times 7 = 11 \times 7 = 77$ and

$$(5 \times 7) + (6 \times 7) = 35 + 42 = 77$$

We see that both are equal.

This is known as distributive property of multiplication over addition.

Using the distributive property find value of ; $2 \times (5 + 6)$; $5 \times (7 + 8)$, $19 \times 7 + 19 \times 3$

Example-3. Find the value of 12×75 using distributive property.

Solution:

$$\begin{aligned} 12 \times 75 &= 12 \times (70 + 5) &&= 12 \times (80 - 5) \\ &= (12 \times 70) + (12 \times 5) \text{ or } &&= (12 \times 80) - (12 \times 5) \\ &= 840 + 60 = 900 &&= 960 - 60 = 900 \end{aligned}$$



DO THIS

Find the values of 25×78 ; 17×26 ; $49 \times 68 + 32 \times 49$ using distributive property.

Identity (for addition and multiplication)

When you add 7 and 5, you get a new whole number 12. Addition of two whole numbers gives a new whole number. But is this always so for all whole numbers?

When we add zero to a whole number, we get the same whole number again.

Observe the table;

$2 + 0 = 2$
$9 + 0 = 9$
$0 + 11 = 11$
$.. + 25 = 25$

Zero is called as the additive identity for whole numbers.

Consider the following table now:

$1 \times 9 = 9$
$6 \times 5 = 30$
$6 \times 4 = 24$
$5 \times 1 = 5$
$11 \times 1 = 11$
$2 \times 3 = 6$

From the above table, we see when we multiply a whole number with 1, the product will be the same whole number. One is called the multiplicative identity for whole numbers.



EXERCISE - 2.2

1. Give the results without actually performing the operations using the given information.
 - i. $28 \times 19 = 532$ then $19 \times 28 =$
 - ii. $1 \times 47 = 47$ then $47 \times 1 =$
 - iii. $a \times b = c$ then $b \times a =$
 - iv. $58 + 42 = 100$ then $42 + 58 =$
 - v. $85 + 0 = 85$ then $0 + 85 =$
 - vi. $a + b = d$ then $b + a =$
2. Find the sum by suitable rearrangement.
 - i. $238 + 695 + 162$
 - ii. $154 + 197 + 46 + 203$
3. Find the product by suitable rearrangement.
 - i. $25 \times 1963 \times 4$
 - ii. $20 \times 255 \times 50 \times 6$
4. Find the value of the following.
 - i. $(368 \times 12) + (18 \times 368)$
 - ii. $(79 \times 4319) + (4319 \times 11)$
5. Find the product using suitable properties.
 - i. 205×1989
 - ii. 1991×1005
6. A milk vendor supplies 56 liters of milk in the morning and 44 liters of milk in the evening to a hostel. If the milk costs ₹ 30 per liter, how much money does he get per day?
7. Chandana and Venu purchased 12 note books and 10 note books respectively. The cost of each note book is ₹ 15, then how much amount should they pay to the shop keeper?
8. Match the following.
 - i. $1991 + 7 = 7 + 1991$ [] a. Additive identity
 - ii. $68 \times 50 = 50 \times 68$ [] b. Multiplicative identity
 - iii. 1 [] c. Commutative under addition
 - iv. 0 [] d. Distributive property of multiplication over addition
 - v. $879 \times (100 + 30) = 879 \times 100 + 879 \times 30$ [] e. Commutative under multiplication

2.4 PATTERNS IN WHOLE NUMBERS

We shall try to arrange numbers in elementary shapes made up of dots. The dots would be placed on a grid with equidistant points along the two axes. The shapes we would make are (i) a line (ii) a rectangle (iii) a square and (iv) a triangle. Every number should be arranged in one of these shapes. No other irregular shape is allowed.

Whole numbers can be shown in elementary shapes made up of dots, observe the following.

- Every number can be arranged as a line
The number 2 is shown as ● ●
The number 3 is shown as ● ● ● and so on.
- Some numbers can also be shown as rectangle.
For example,

The number 6 can be shown as



In this rectangle observe that there are 2 rows and 3 columns.

- Some numbers like 4 or 9 can also be arranged as squares.

4



9



What are the other numbers that form squares like this? We can see a pattern here.

$4 = 2 \times 2$ this is a perfect square.

$9 = 3 \times 3$ this is also a perfect square.

What will be the next number which can be arranged like a square?

Easily we can observe that $4 \times 4 = 16$ and 16 is the next number which is a perfect square.

Find the next 3 numbers that can be arranged as squares.

Give 5 numbers that can be arranged as rectangles that are not squares.

- Some numbers can also be arranged as triangles.

3



6



Note that the arrangement as a triangle would have its two sides equal. The number of dots from the bottom row can be like 4, 3, 2, 1. The top row always contains only one dot, so as to make one vertex.

What is the next possible triangle? And the next.

Do you observe any pattern here? Observe the number of dots in each row and think about it. Now complete the following table:

Number	Line	Rectangle	Square	Triangle
2	Yes	No	No	No
3	Yes	No	No	Yes
4	Yes	No	Yes	No
5				
.....				
25				

Is 1 a square or not? why?



TRY THESE

1. Which numbers can be shown as a line only?
2. Which numbers can be shown as rectangles?
3. Which numbers can be shown as squares?
4. Which numbers can be shown as triangles? eg. 3, 6,

Patterns of numbers

We can use patterns to guide us in simplifying processes. Study the following:

1. $296 + 9 = 296 + 10 - 1 = 306 - 1 = 305$
2. $296 - 9 = 296 - 10 + 1 = 286 + 1 = 287$
3. $296 + 99 = 296 + 100 - 1 = 396 - 1 = 395$
4. $296 - 99 = 296 - 100 + 1 = 196 + 1 = 197$

Let us see one more pattern:

1. $65 \times 99 = 65 (100 - 1) = 6500 - 65 = 6435$
2. $65 \times 999 = 65 (1000 - 1) = 65000 - 65 = 64935$
3. $65 \times 9999 = 65 (10000 - 1) = 650000 - 65 = 649935$
4. $65 \times 99999 = 65 (100000 - 1) = 6500000 - 65 = 6499935$ and so on.

Here, we can see a shortcut to multiply a number by numbers of the form 9, 99, 999,

This type of shortcuts enable us to do sums mentally.

Observe the following pattern: It suggests a way of multiplying a number by 5, 15, 25,

(You can think of extending it further).

$$\text{a. } 46 \times 5 = 46 \times \frac{10}{2} = \frac{460}{2} = 230 = 230 \times 1$$

$$\begin{aligned} \text{b. } 46 \times 15 &= 46 \times (10 + 5) \\ &= 46 \times 10 + 46 \times 5 = 460 + 230 = 690 = 230 \times 3 \end{aligned}$$

$$\begin{aligned} \text{c. } 46 \times 25 &= 46 \times (20 + 5) \\ &= 46 \times 20 + 46 \times 5 = 920 + 230 = 1150 = 230 \times 5 \dots \end{aligned}$$

Can you tell some more examples for using such processes to simplify calculations?



EXERCISE - 2.3

1. Study the pattern:

$$1 \times 8 + 1 = 9$$

$$12 \times 8 + 2 = 98$$

$$123 \times 8 + 3 = 987$$

$$1234 \times 8 + 4 = 9876$$

$$12345 \times 8 + 5 = 98765$$

Write the next four steps. Can you find out how the pattern works?



2. Study the pattern:

$$91 \times 11 \times 1 = 1001$$

$$91 \times 11 \times 2 = 2002$$

$$91 \times 11 \times 3 = 3003$$

Write next seven steps. Check, whether the result is correct.

Try the pattern for $143 \times 7 \times 1$, $143 \times 7 \times 2$

3. How would we multiply the numbers 13680347, 35702369 and 25692359 with 9 mentally? What is the pattern that emerges?



WHAT HAVE WE DISCUSSED?

1. The numbers 1, 2, 3, which we use for counting are known as natural numbers.
2. Every natural number has a successor. Every natural number except 1 has a predecessor.
3. If we include the number 'zero' to the collection of natural numbers, we get the collection of whole numbers $W = \{0, 1, 2, \dots\}$.
4. Every whole number has a successor. Every whole number except zero has a predecessor.
5. All natural numbers are whole numbers, and all whole numbers except zero are natural numbers.
6. We can make a number line with whole numbers represented on it. We can easily perform the number operations of addition, subtraction and multiplication on such a number line.
7. Addition corresponds to moving to the right on the number line, where as subtraction corresponds to moving to the left. Multiplication corresponds to making jumps of equal distance from zero.
8. Whole numbers are closed under addition and multiplication. But whole numbers are not closed under subtraction and division.
9. Division by zero is not defined.
10. Zero is the additive identity and 1 is the multiplicative identity of whole numbers.
11. Addition and multiplication are commutative for whole numbers.
12. Addition and multiplication are associative for whole numbers.
13. Multiplication is distributive over addition for whole numbers.
14. Commutativity, associativity and distributivity of whole numbers are useful in simplifying calculations and we often use them without being aware of them.
15. Pattern with numbers are not only interesting, but are useful especially for mental calculations. They help us to understand properties of





3.1 INTRODUCTION

Let us observe the situation.

Hasini wants to distribute chocolates to her classmates on her birthday. Her father brought a box of 125 chocolates. There are 25 students in her class.

She decided to distribute all the chocolates such that each one would get equal number of chocolates. First, she thought of giving 2 chocolates each but found that some chocolates were remaining. Then again she tried of giving 3 each, but again some chocolates were remaining. Finally, she thought of giving 5 chocolates each. Now, she found that no chocolates were remaining.

Is there any easy way to find the no. of chocolates equally distributed among her classmates? Think. Of course she can divide 125 by 25. In the previous classes you have become familiar with rules which tell us whether a given number is divisible by 2, 3, 5, 6, 9 and 10. In this chapter we will recollect these tests. Further, we will also discover the rules of divisibility for 4, 8 and 11.



3.2 DIVISIBILITY RULE

Let us consider 29. When you divide 29 by 4, it leaves remainder 1 and gives quotient 7. Can you say that 29 is completely divisible by 4? Why?

Find the quotient and remainder when 24 is divided by 4?

Is 24 completely divisible by 4? Why?

So, we see that a number is completely divisible by another number, when it leaves zero as remainder.

The process of checking whether a number is divisible by a given number or not without actual division is called divisibility rule for that number.

Let us review the tests of divisibility studied in the previous classes.

3.2.1 Divisibility by 2

Let us look at the number chart given below.

1	2	3	4	5	6	7	8	9	10
11	12	13	14	15	16	17	18	19	20
21	22	23	24	25	26	27	28	29	30
31	32	33	34	35	36	37	38	39	40
41	42	43	44	45	46	47	48	49	50
51	52	53	54	55	56	57	58	59	60
61	62	63	64	65	66	67	68	69	70
71	72	73	74	75	76	77	78	79	80
81	82	83	84	85	86	87	88	89	90
91	92	93	94	95	96	97	98	99	100

Now cross all the multiples of 2. Do you see any pattern in the ones place of these numbers?

These numbers have only the digits 0, 2, 4, 6, 8 in the ones place. Looking at these observations we can say that **a number is divisible by 2 if it has any of the digits 0, 2, 4, 6 or 8 in its ones place.**



DO THIS

Are 953, 9534, 900, 452 divisible by 2? Also check by actual division.

3.2.2 Divisibility by 3

Now encircle all the multiples of 3 in the above chart. You must have encircled numbers like 21, 27, 36, 54 etc. Do you see any pattern in the ones place of these numbers. No! Because numbers with the same digit in ones place may or may not be divisible by 3. For example, both 27 and 37 have 7 in ones place. Are they both divisible by 3?

Let us now add the digits of 21, 36, 54, 63, 72, 117

$$2 + 1 = 3$$

$$5 + 4 = \underline{\quad}$$

$$7 + 2 = \underline{\quad}$$

$$3 + 6 = \underline{\quad}$$

$$6 + 3 = \underline{\quad}$$

$$1 + 1 + 7 = \underline{\quad}$$

All these sums are divisible by 3.

Thus we can say that **if the sum of the digits is divisible by of 3, then the number is divisible by 3.** Check this rule for other circled numbers.



Do THIS

Check whether the following numbers are divisible by 3?

i. 45986

ii. 36129

iii. 7874

3.2.3 Divisibility by 6

Put a cross on the numbers which are multiples of 6 in the number chart.

Do you notice anything special about them?

Yes, they are divisible by both 2 and 3.

If a number is divisible by both 2 and 3 then it is also divisible by 6.



TRY THESE

1. Is 7224 divisible by 6? Why?
2. Give two examples of 4 digit numbers which are divisible by 6.
3. Can you give an example of a number which is divisible by 6 but not by 2 and 3? Why?

3.2.4 Divisibility by 9

Put a (box) on the numbers which are multiples of 9 in the number chart.

Now try to find a pattern or rule for checking the divisibility of 9. (Hint : Sum of digits)

Sum of digits in these numbers are also divisible by 9.

For example If we take 81, $8 + 1 = 9$ similarly 99, $9 + 9 = 18$ divisible by 9.

A number is divisible by 9, if the sum of the digits of the number is divisible by 9.



Do THIS

1. Test whether 9846 is divisible by 9?
2. Without actual division, find whether 8998794 is divisible by 9?
3. Check whether 786 is divisible by both 3 and 9?

3.2.5 Divisibility by 5

Are all the numbers 20, 25, 30, 35, 40, 45, 50 divisible by 5?

Is 53 divisible by 5? Why?

Can you say that all the numbers with zero and five at ones place is divisible by 5?

Consider the numbers 5785, 6021, 1000, 101010, 9005. Guess which are divisible

3.2.6 Divisibility by 10

Mark all the numbers divisible by 10 with a tick (✓) in the number chart.

What do you notice?

- All of them have 0 at their ones place.
- All of them are divisible by both 2 and 5.



EXERCISE - 3.1

- Which of the following numbers are divisible by 2, by 3 and by 6?

- (i) 321729 (ii) 197232 (iii) 972132 (iv) 1790184
 (v) 312792 (vi) 800552 (vii) 4335 (viii) 726352

- Determine which of the following numbers are divisible by 5 and by 10.

25, 125, 250, 1250, 10205, 70985, 45880

Check whether the numbers that are divisible by 10 are also divisible by 2 and 5.

- Fill the table using divisibility test for 3 and 9.

Number	Sum of the digits in the number	Divisible by	
		3	9
72		
197		
4689		
79875		
988974	$9 + 8 + 8 + 9 + 7 + 4 = 45$	Yes	Yes

- Make 3 different 3 digit numbers using 1, 9 and 8, where each digit can be used only once. Check which of these numbers are divisible by 9.

- Which numbers among 2, 3, 5, 6, 9 divides 12345 exactly?

Write 12345 in reverse order and test now which numbers among 2, 3, 5, 6 and 9 divide it exactly?

- Write different 2 digit numbers using digits 3, 4 and 5. Check whether these numbers are divisible by 2, 3, 5, 6 and 9?

- Write the smallest and the greatest possible digit in the blank space of each of the following numbers so that the numbers formed are divisible by 3.

- i. 6724 ii. 4765 2 iii. 7221 5

- Find the smallest number that must be added to 123, so that it becomes exactly divisible by 5?

- Find the smallest number that has to be subtracted from 256, so that it becomes exactly divisible by 10?

3.3 FACTORS

We have studied the divisibility and discovered tests of divisibility for 2, 3, 5, 6, 9 and 10. Now we will learn the concepts of factors.

Let us observe a situation:

Devi has 6 laddoos with her. She wants to arrange them in columns in such a way that each column has the same number of laddoos. She arranges them in many ways using all the 6 laddoos.

Case (i) 1 laddoo in each column
number of columns = 6 
Total number of laddoos = $1 \times 6 = 6$

 **Case (ii)** 2 laddoos in each column
Number of columns = 3
Total number of laddoos = $2 \times 3 = 6$

 **Case (iii)** 3 laddoos in each column
Number of columns = 2
Total number of laddoos = $3 \times 2 = 6$

 **Case (iv)** 6 laddoos in each column
Number of column = 1
Total number of laddoos = $6 \times 1 = 6$

These are the only possible arrangements using all the 6 laddoos.

From these arrangements, Devi observes that 6 can be written as a product of two numbers in different ways as

$$6 = 1 \times 6 \quad 6 = 2 \times 3 \quad 6 = 3 \times 2 \quad 6 = 6 \times 1$$

From $6 = 2 \times 3$ it can be said that 2 and 3 exactly divide 6. So, 2 and 3 are factors of 6. From the other product $6 = 1 \times 6$, thus 6 and 1 are also factors of 6.

1, 2, 3 and 6 are the only factors of 6.

"A number which divides the other number exactly is called a **factor** of that number."

In other words, every number is completely divisible by its factors. Here 1, 2, 3 and 6 are all factors of 6. Similarly 1 and 19 are factors of 19. Number 5 is not a factor of 16. Why?

Observe the following table:

Number	Factors
12	1, 2, 3, 4, 6, 12
18	1, 2, 3, 6, 9, 18
20	1, 2, 4, 5, 10, 20
24	1, 2, 3, 4, 6, 8, 12, 24

From the above table we can notice that;

- (ii) Every number is a factor to itself and it is the biggest factor of it.
- (iii) Every factor of a number is less than or equal to the given number.
- (iv) Number of factors of a given number are countable.



DO THIS

1. Find the factors of 80.
2. Do all the factors of a given number divide the number exactly? Find the factors of 28 and verify by division.
3. 3 is a factor of 15 and 24. Is 3 a factor of their difference also?

3.4 PRIME AND COMPOSITE NUMBERS

Let us observe the number of factors of a few numbers in the table given below:

Number	Factors	Number of Factors
1	1	1
2	1, 2	2*
3	1, 3	2*
4	1, 2, 4	3
5	1, 5	2*
6	1, 2, 3, 6	4
7	1, 7	2*

From the table say which numbers have only two factors?

There are four numbers 2, 3, 5 and 7 having exactly two factors (shown with*)
i.e. 1 and the number itself.

These numbers whose only factors are 1 and the number itself are called prime numbers.

Which numbers have more than two factors?

Numbers having more than two factors like 4, 6 and so on are called **composite numbers**.

Give 5 examples of composite numbers greater than 10.

Which number has only one factor?

The number 1 has only one factor (i.e. itself) so, **1 is neither prime nor composite.**



TRY THESE

1. What is the smallest Prime number?
2. What is the smallest composite number?
3. What is the smallest odd composite number?
4. Give 5 odd and 5 even composite numbers?
5. Is 1 prime or composite? state reasons.

Without actually checking the factors of a number, we can find prime numbers from 1 to 100 with an easy method. This method was given by the Greek Mathematician **Eratosthenes**, in the third century BC.

Let us see the method. List all the numbers from 1 to 100, as shown below:

1	2	3	4	5	6	7	8	9	10
11	12	13	14	15	16	17	18	19	20
21	22	23	24	25	26	27	28	29	30
31	32	33	34	35	36	37	38	39	40
41	42	43	44	45	46	47	48	49	50
51	52	53	54	55	56	57	58	59	60
61	62	63	64	65	66	67	68	69	70
71	72	73	74	75	76	77	78	79	80
81	82	83	84	85	86	87	88	89	90
91	92	93	94	95	96	97	98	99	100

Step-1: Cross out 1 because it is neither prime nor composite.

Step-2: Encircle 2, cross out all the other multiples of 2, i.e. 4, 6, 8 and so on.

Step-3: You will find that the next uncrossed number is 3. Encircle 3 and cross out all the other multiples of 3.

Step-4: The next uncrossed number is 5. Encircle 5 and cross out all the other multiples of 5.
If any number is crossed leave it.

Step-5: Continue this process till all the numbers in the list are either encircled or crossed out.

All the encircled numbers are prime numbers. All the crossed out numbers, other than 1 are composite numbers.



TRY THESE

1. Can you guess a prime number which when on reversing its digits, gives another prime number? (**Hint** : Take a 2 digit prime number and observe)
2. You know 311 is a prime number. Can you find the other two prime numbers just by rearranging the digits?

3.4.1 Co-prime or relative prime

Observe the numbers 3 and 8.

The factors of 3 are 1 and 3

The factors of 8 are 1, 2, 4 and 8.

The common factor for both 3 and 8 is 1 only.

Thus, the numbers which have only 1 as the common factor are called **co-primes** or **relatively prime**. Write two pairs of co-primes, by finding the common factor.

Example-1. Consider two co-prime numbers 4 and 5. Are both of them prime numbers?

Solution: No, 4 is not a prime. Only 5 is a prime.

We can say that "**Only two primes are co-primes but all the co-primes need not be primes.**"

3.4.2 Twin primes

Twin primes are prime numbers that differ from each other by two e.g. (3, 5), (5, 7), (11, 13), (41, 43) etc.

Are all twin primes relatively prime? Discuss



DO THIS

From the following numbers identify different pairs of co-primes
2, 3, 4, 5, 6, 7, 8, 9 and 10



EXERCISE - 3.2

- Write all the factors of the following numbers.
i) 36 ii) 23 iii) 96 iv) 115
- Which of the following pairs are co-prime?
i) 18 and 35 ii) 216 and 215
iii) 30 and 415 iv) 17 and 68
- What is the greatest prime number between 1 and 20?
- Find the prime and composite numbers between 10 and 30.
- The numbers 17 and 71 are prime numbers. Both these numbers have same digits 1 and 7. Find 2 more such pairs of prime numbers below 100?
- Write three pairs of twin primes below 20.
- Write two prime numbers whose product is 35.
- Express 36 as the sum of two odd primes.
- Write seven consecutive composite numbers less than 100.
- Express 53 as the sum of three primes.
- Write two prime numbers whose difference is 10.

3.5 PRIME FACTORIZATION

When a number is expressed as a product of its factors, we say that the number has been factorized. The process of finding the factors is called **factorization**.

There may be several ways in which a number can be factorized. For example, the number 24 can be factorized as:

- i) $24 = 1 \times 24$ ii) $24 = 2 \times 12$ iii) $24 = 3 \times 8$
 iv) $24 = 4 \times 6$ v) $24 = 2 \times 2 \times 2 \times 3$

In (ii) and (iii) one factor is prime, and the other factor is a composite number. In (iv) both the factors are composite numbers. However in (v) all the factors are **prime numbers**. In (i) one factor is composite.

Factorization of the type (v), where all the factors are prime numbers, is known as **prime factorization**.

Thus, in prime factorization, the factors obtained cannot be further factorized.

3.5.1 Methods of Prime Factorization

1. **Division Method:** Prime factorisation of 42 using division method we proceed as follow:

$$\begin{array}{r|l} 2 & 42 \\ \hline 3 & 21 \\ \hline 7 & 7 \\ \hline & 1 \end{array}$$

Start dividing by the least prime factor. Continue division till the resulting number to be divided is 1.

∴ Prime factorisation of 42 is $2 \times 3 \times 7$

2. **Factor Tree Method:** We can find the prime factorization of 60 by drawing a factor tree. To find the prime factorization of 60 using factor tree method.

Steps in this method:

Step-1: Express 60 as a product of two numbers.

Step-2: Factorise 4 and 15 further, since they are composite numbers.

Step-3: Continue till all the factors are prime numbers.

Prime factorisation of $60 = 2 \times 2 \times 3 \times 5$

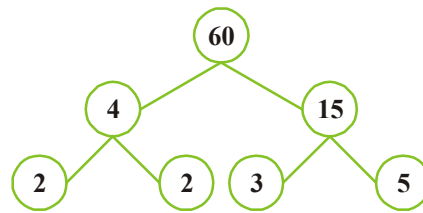

DO THIS

- Write the prime factors of 28 and 36 through division method.
- Write the prime factors of 42 by factor tree method.



EXERCISE - 3.3

1. Write the missing numbers in the factor tree for 90?

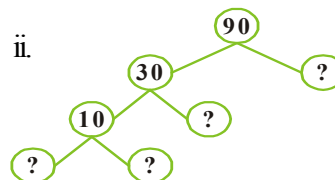
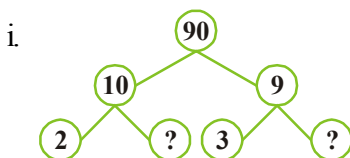

- Factorise 84 by division method?
- Write the greatest 4 digit number and express it in the form of its prime factors?
- I am the smallest number, having four different prime factors. Can you find me? Explain.

3.6 COMMON FACTORS

Observe the following table:

Number	12	18
Factors of the number	1, 2, 3, 4, 6, 12	1, 2, 3, 6, 9, 18

Common factors of 12 and 18 are 1, 2, 3 and 6 (Whether any other factors are common for 12 and 18 from the table)

Common factors are those numbers which are factors of all the given numbers.

Now find common factor of 20 and 24.

3.6.1 Highest Common Factor (HCF)

From the above table we found that common factors of 12 and 18 are 1, 2, 3 and 6.

What is the highest of these common factors? It is 6. So we can say that the Highest Common Factor (HCF) of 12 and 18 is 6.

The Highest Common Factor (HCF) of two or more given numbers is the highest (or greatest) of their common factors. It is also called as Greatest Common Divisor (GCD)

3.6.2 Method of finding HCF

1. Prime Factorisation Method

The HCF of 12, 30 and 36 can also be found by prime factorisation as follows:

2	12
2	6
3	3
	1

2	30
3	15
5	5
	1

3	36
3	12
2	4
2	2
	1

Thus

$$12 = 2 \times 2 \times 3$$

$$30 = 2 \times 3 \times 5$$

$$36 = 2 \times 2 \times 3 \times 3$$

The common factor of 12, 30 and 36 is $2 \times 3 = 6$.

Hence, HCF of 12, 30 and 36 is 6.



DO THIS

Find the HCF of 12, 16 and 28

2. HCF by Continued Division Method

This method of division was invented by the famous Greek mathematician **Euclid**. Divide the larger number by the smaller and then divide the previous divisor by the remainder until the remainder is 0. The **last divisor is the HCF** of the numbers.

Example-2. Find the HCF of 56 and 64

Solution:

$$\begin{array}{r} 56) 64 (1 \\ \underline{-56} \\ \text{Last divisor } 8) 56 (7 \\ \underline{-56} \\ \text{Remainder } 0 \end{array}$$

Last divisor is 8 when remainder becomes 0. Thus, HCF of 56 and 64 is 8.

This method is useful to find the HCF of larger numbers.

Example-3. Find the HCF of 40, 56 and 60.

Solution:

Step-1: First find the HCF of any two numbers. Let us find the HCF of 40 and 56.

$$\begin{array}{r} 40) 56 (1 \\ \underline{-40} \\ \text{Remainder } 16) 40 (2 \\ \underline{-32} \\ \text{Last Divisor } 8) 16 (2 \\ \underline{-16} \\ \text{Remainder } 0 \end{array}$$

HCF of 40 and 56 is 8.

Step-2: Then, find the HCF of the third number and the HCF of first two numbers.

Let us find the HCF of 60 and 8.

$$\begin{array}{r} 8) 60 (7 \\ \underline{-56} \\ \text{Last Divisor } 4) 8 (2 \\ \underline{-8} \\ \text{Remainder } 0 \end{array}$$

HCF of 8 and 60 is 4.

Step-3: This number is the HCF of the given three numbers.

Thus HCF of 40, 56 and 60 is 4.



Do This

Find the HCF of 28, 35 and 49.

THINK, DISCUSS AND WRITE

Find the HCF of

- (i) any two consecutive numbers
- (ii) any two consecutive even numbers
- (iii) any two consecutive odd numbers

What do you observe? Discuss with your friends.



Example-4. Two tankers contain 850 litres and 680 litres of kerosene oil, respectively. Find the maximum capacity of a container which can measure the kerosene oil of both the tankers when used an exact number of times.

Solution: The required container has to measure both the tankers in a way that the count is an exact number of times. So its capacity must be an exact divisor of the capacities of both the tankers. Moreover this capacity should be **maximum**. Thus the maximum capacity of such a container will be the HCF of 850 and 680. The **HCF** of 850 and 680 is 170.

Therefore, maximum capacity of the required container is 170 litres. It will fill the first container in 5 and the second in 4 refills.



EXERCISE - 3.4

1. Find the HCF of the following numbers by prime factorisation and continued division method?
 - i. 18, 27, 36 ii. 106, 159, 265
 - iii. 10, 35, 40 iv. 32, 64, 96, 128
2. Find the largest number which is a factor of each of the numbers 504, 792 and 1080?
3. The length, breadth and height of a room are 12m, 15m and 18m respectively. Determine the length of longest stick that can measure all the dimensions of the room in exact number of times?
4. HCF of co-prime numbers 4 and 15 was found as follows by factorisation:
 $4 = 2 \times 2$ and $15 = 3 \times 5$ Since there is no common prime factor, HCF of 4 and 15 is 0. Is the answer correct? If not, what is the correct HCF?
5. What is the capacity of the largest vessel which can empty the oil from three vessels containing 32 litres, 24 litres and 48 litres an exact number of times?

3.7 COMMON MULTIPLES

The multiples of 4 and 6 are

Multiples of 4 = 4, 8, 12, 16, 20, 24, 28, 32, 36,,,

Multiples of 6 = 6, 12, 18, 24, 30, 36, 42, 48,,,

Common multiples of both 4 and 6 = 12, 24, 36,,,

3.7.1 Least common Multiple (LCM)

Common multiples of both 4 and 6 are 12, 24, 36,,,

Least of them is 12.

That means 12 is the lowest among the common multiples of both 4 and 6.

∴ Lowest Common Multiple (LCM) of 4 and 6 is 12

Example-5. Two bells ring together. If the bells ring at every 3 minutes and 4 minutes respectively. After what interval of time will they ring together again?

Solution: First bell rings after every 3 minutes.

i.e. First bell rings at 3 min, 6, 9, 12, 15, 18, 21, 24,,, (multiples of 3)

Second bell rings after every 4 minutes.

i.e., Second bell rings at 4 min, 8, 12, 16, 20, 24,,, (multiples of 4)

both bells ring together after 12 min., 24 min,,, (common multiples of both 3 and 4). Least of them (LCM) is 12 min.

That means after 12 minutes they ring together again.

Thus, we can say that

The least common multiple of two or more given numbers is the lowest (or smallest or least) of their common multiples.

Instead of writing all the common multiples of the given numbers every time to identify the least one of them, we can just find the LCM of those numbers directly.

3.7.2 Methods of Finding LCM

1. Prime Factorization Method

The LCM of 36 and 60 can be found by prime factorization method as follows:-

Step-1: Express each number as a product of prime factors.

$$\text{Factors of 36} = \boxed{2} \times \boxed{2} \times \boxed{3} \times 3$$

$$\text{Factors of 60} = \boxed{2} \times \boxed{2} \times \boxed{3} \times 5$$

Step-2: Take the common factors of both: $2 \times 2 \times 3$

Step-3: Take the remaining factors of both 36 and 60 i.e. 3 and 5.

Step-4: LCM is found by the product of all common prime factors of two numbers and extra prime factors of both.

$$\text{Hence, the LCM of 36 and 60} = (2 \times 2 \times 3) \times 3 \times 5 = 180$$



TRY THIS

1. Find LCM of

i. 3, 4

ii. 10, 11

iii. 5, 6, 7

iv. 10, 30

v. 4, 12, 24

vi. 3, 12

What do you observe?

If one of the two given numbers is a multiple of the other, then the greater number is the LCM of the given numbers.

2. Division Method

To find the LCM of 24 and 90:

2	24, 90
3	12, 45
	4, 15

Step-1: Arrange the given numbers in a row.

Step-2: Then divide by a least prime number which divides at least two of the given numbers and carry forward the numbers which are not divisible by that number if any.

Step-3: Repeat the process till numbers have no common factor other than 1.

Step-4: LCM is the product of the divisors and the remaining numbers.

Thus, the LCM of 24 and 90 is $2 \times 3 \times 4 \times 15 = 360$

Example-6. Find the LCM of 21, 35 and 42.

Solution:

7	21, 35, 42
3	3, 5, 6
	1, 5, 2

Thus, the LCM of 21, 35 and 42 is $7 \times 3 \times 5 \times 2 = 210$

THINK, DISCUSS AND WRITE

When will the LCM of two or more numbers be their own product?



EXERCISE - 3.5

- Find the LCM of the following numbers by prime factorisation method.
 - 12, 15
 - 15, 25
 - 14, 21
 - 18, 27
 - 48, 56, 72
 - 26, 14, 91
- Find the LCM of the following numbers by division method.
 - 84, 112, 196
 - 102, 119, 153
 - 45, 99, 132, 165
- Find the smallest number which when added to 5 is exactly divisible by 12, 14 and 18.
- Find the greatest 3 digit number which when divided by 75, 45 and 60 leaves:
 - no remainder
 - the remainder 4 in each case
- Prasad and Raju met in the market on 1st of this month. Prasad goes to the market every 3rd day and Raju goes every 4th day. On what day of the month will they meet again?

3.8 RELATIONSHIP BETWEEN LCM AND HCF

Consider the numbers 18 and 27.

Product of prime factors of 18 = $2 \times 3 \times 3$; Product of prime factors of 27 = $3 \times 3 \times 3$

LCM of 18 and 27 = $3 \times 3 \times 3 \times 2 = 54$

HCF of 18 and 27 = $3 \times 3 = 9$

LCM \times HCF = $54 \times 9 = 486$

Product of 18 and 27 = $18 \times 27 = 486$

What do you observe?

We observe that **Product of LCM and HCF of the two numbers = Product of the two numbers.**

Example 7. Find the LCM of 8 and 12 and then find their HCF using the above relation

Solution: LCM of 8 and 12 = $2 \times 3 \times 4 = 24$

We know, LCM \times HCF = product of the two numbers

$$\begin{aligned} \text{HCF} &= \frac{\text{Product of the two numbers}}{\text{LCM}} \\ &= \frac{8 \times 12}{24} = 4 \end{aligned}$$

Hence, HCF of 8 and 12 = 4

4		8, 12
		2, 3

THINK, DISCUSS AND WRITE

1. What is the LCM and HCF of co-prime numbers?
2. Interpret relationship between LCM and HCF of any two numbers.



EXERCISE - 3.6

1. Find the LCM and HCF of the following numbers.
i) 15, 24 ii) 8, 25 iii) 12, 48
Check their relationship.
2. If the LCM of two numbers is 216 and their product is 7776, what will be the HCF?
3. The product of two numbers is 3276. If their HCF is 6, find their LCM?
4. The HCF of two numbers is 6 and their LCM is 36. If one of the numbers is 12, find the

3.9 DIVISIBILITY RULES FOR 4, 8 AND 11

We have learnt the divisibility rules for 2, 3, 5, 6, 9 and 10. Now, we derive the divisibility rule for 4, 8 and 11.

3.9.1 Divisibility Rule for 4

Observe the pattern

Number	Can be written as	Whether divisible by 4?
100	100	Yes
600	6×100	Yes
1000	10×100	Yes
10000	100×100	Yes
100000	1000×100	Yes

From the above table, we can observe that 100 is divisible by four. Here 600, 1000, 10000, 100000 can be expressed as a multiple of 100. So, these numbers are also divisible by 4.

You know that all even numbers are divisible by 2.

Are all even numbers also divisible by 4?

Let us verify.

126 is an even number divisible by 2. Is 126 divisible by 4?

126 can be written as $126 = 100 + 26$

You know that 100 is divisible by 4. But 26 is not divisible by 4.

Hence, we can say that all even numbers are not necessarily divisible by 4.

For example, consider 76532.

76532 can be written as $70000 + 6000 + 500 + 30 + 2$.

You know that 100, 1000, 10000 are multiples of 100, and 100 is divisible by 4. So we need not test them every time. So, it is enough to test the last two digits of the given number i.e. 32. Is 32 divisible by 4? Yes. It is divisible by 4. Hence, we can say that 76532 is also divisible by 4.

You already know that odd numbers are not divisible by 4.

A number is divisible by 4, if the number formed by its last two digits (i.e. tens and ones) is divisible by 4.

Note: This rule works for number greater than hundred. For smaller numbers (1 or 2 digit numbers) we have to do actual division.

Example-8. Verify whether 56496 is divisible by 4?

Solution: $56496 = 50000 + 6000 + 400 + 96$

We already know that 50000, 6000, 400 are all multiples of 100, they are completely divisible by 4.

We need to test whether 96 (the last two digits) is divisible by 4 or not.

96 is divisible by 4.

So, the given number 56496 is also divisible by 4



DO THIS

1. Is 100000 divisible by 4? Why?
2. Give an example of a 2 digit number that is divisible by 2 but not divisible by 4?

3.9.2 Divisibility Rule for 8

We have learnt the divisibility rule for 4. It is based on expanding the number. Since 10 is not divisible by 4 so we consider 100 and any number greater than 100 can be written as multiple of 100, so if the last two digits are divisible by four it will be divisible by 4. Similarly since 10 is not divisible by 8, we think of 1000.

Is 100 divisible by 8? No

Is 1000 divisible by 8? Yes

We know that any number greater than 1000 can be written as something added to multiple of 1000. For example $4825 = 4 \times 1000 + 825$.

Thus we can say that if last three digits of a number is divisible by 8 then the number will be divisible by 8. Let us see an example-

Example-9. Verify whether 93624 is divisible by 8?

Solution: $93624 = 90000 + 3000 + 600 + 20 + 4$

We know that 1000 is divisible by 8.

Here, 90000 and 3000 are multiples of 1000, they are certainly divisible by 8.

So, it is enough to test the divisibility of the last three digits of the number.

Is 624 divisible by 8? Yes.

A number with 4 or more digits is divisible by 8, if the number formed by its last three digits is divisible by 8. The divisibility for numbers with 1, 2 or 3 digits by 8 has to be checked by actual division.



Do This

1. Is 76104 divisible by 8?
2. Write the numbers that are divisible by 8 & lie between 100 and 200?

3.9.3 Divisibility Rule for 11

Fill in the blanks and complete the table.

Number	Sum of the digits at odd places (from the right)	Sum of the digits at even places (from the right)	Difference	Is the difference divisible by 11
29843				
90002				
80927				
19091908	$8+9+9+9=35$	$0+1+0+1=2$	$35-2=33$	Yes
83568				

What do you observe from the table?

We observe that in each case the difference is either 0 or divisible by 11. All these numbers are also divisible by 11.

For the number 83568, the difference is 12 which is not divisible by 11. The number 83568 is also not divisible by 11.

A given number is divisible by 11, if the difference between the sum of the digits at odd places and the sum of the digits at even places (from the right) is either 0 or divisible by 11.

Example-10. Is 6535 divisible by 11?

Solution: Sum of the digits at odd places = $5 + 5 = 10$

Sum of the digits at even places = $3 + 6 = 9$

Their difference = $10 - 9 = 1$

Is 1 divisible by 11? No

So, 6535 is not divisible by 11.

Example-11. Is 1221 divisible by 11?

Solution: Sum of the digits at odd places = $1 + 2 = 3$

Sum of the digits at even places = $2 + 1 = 3$

Their difference = $3 - 3 = 0$

So, 1221 is divisible by 11.



TRY THESE

1221 is a **Palindrome number**, which on reversing their digits gives the same number. Thus, every Palindrome number with even number of digits, is always divisible by 11.

Write a Palindrome number of 6 digits and verify whether it is divisible by 11 or not?



EXERCISE - 3.7

- Which of the following numbers are divisible by 4?
 - 572
 - 21,084
 - 14,560
 - 1,700
 - 2150
- Test whether the following numbers are divisible by 8?
 - 9774
 - 5,31,048
 - 5500
 - 6136
 - 4152
- Check whether the following numbers are divisible by 11?
 - 859484
 - 10824
 - 20801
- Verify whether the following numbers are divisible by 4 and by 8?
 - 2104
 - 726352
 - 1800
- Find the smallest number that must be added to 289279, so that it is divisible by 8?
- Find the smallest number that can be subtracted from 1965, so that it becomes divisible by 4?
- Write all the possible numbers between 1000 and 1100, that are divisible by 11?
- Write the nearest number to 1240 which is divisible by 11?
- Write the nearest number to 105 which is divisible by 4?



WHAT HAVE WE DISCUSSED?

- We have discussed multiples, divisors, factors and have seen how to identify factors and multiples.
- We have discussed the following:
 - A factor of a number is an exact divisor of that number.
 - Every number is a factor of itself. 1 is a factor of every number.
 - Every factor of a number is less than or equal to the given number.
 - Every number is a multiple of each of its factors.
 - Every multiple of a given number is greater than or equal to that number.
 - Every number is a multiple of itself.



3.
 - i) The number other than 1, with only factors namely 1 and the number itself, is a prime number. Numbers that have more than two factors are called composite numbers. Number 1 is neither prime nor composite.
 - ii) 2 is the smallest prime number and is even. Every prime number other than 2 is odd.
 - iii) Two numbers with only 1 as a common factor are called co-prime numbers.
 - iv) If a number is divisible by another number then it is divisible by each of the factors of that number.
 - v) A number divisible by two co-prime numbers is divisible by their product also.
4. We have discussed how we can find just by looking at a number, whether it is divisible by small numbers 2, 3, 4, 5, 8, 9 and 11. We have explored the relationship between digits of the numbers and their divisibility by different numbers.
 - i) Divisibility by 2, 5 and 10 can be seen by just the last digit.
 - ii) Divisibility by 3 and 9 is checked by finding the sum of all digits.
 - iii) Divisibility by 4 and 8 is checked by the last 2 and 3 digits respectively.
 - iv) Divisibility of 11 is checked by comparing the sum of digits at odd and even places.
5. We have discovered that if two numbers are divisible by a number then their sum and difference are also divisible by that number.
6.
 - i) The Highest Common Factor (HCF) of two or more given numbers is the highest of their common factors.
 - ii) The Least Common Multiple (LCM) of two or more given numbers is the lowest of their common multiples.
7. If one of the two given numbers is a multiple of the other, then the greater number will be their LCM.
8. Relationship between LCM and HCF: $LCM \times HCF = \text{Product of the two numbers}$.

Dattathreya Ramachandra Kaprekar (India)

1905 - 1986 AD

He is a teacher, who played with numbers.

6174 is known as Kaprekar's constant.

He generated demlo numbers and self numbers.





4.1 INTRODUCTION

We see a variety of things around us. There are buildings, utensils, furniture, pictures and lot more. You must have seen rangoli or mehendi designs. Have you ever made these? How do you make these designs?

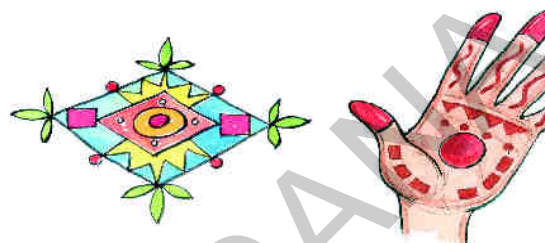

We use various geometrical shapes in them.

Observe some objects around you and identify what shapes you can see in them. For eg., screen of TV is in rectangular shape. Similarly, face of a fridge, pencil box, book etc. are also in rectangular shape. But what about a glass, bindi, flower etc? We have learnt about some geometrical shapes in earlier classes. In this chapter, we will learn more about such geometrical shapes.

4.2 POINT

Take a sharpened pencil and mark a dot on the paper. As you take even more sharper pencil, the dot will become smaller. Observe the almost invisible tiny dot. It will give you an idea of a point. A point determines a location. Think of some examples which look like points.

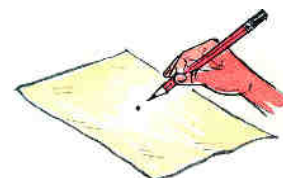

The distant stars also give us an idea of point. We use a point to locate Hyderabad in Telangana map. Think more examples where you use a point to locate some specific thing in a picture, diagram or map.

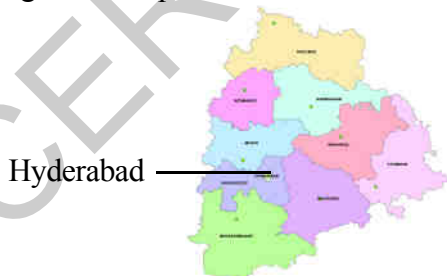

A point is denoted by a capital letter. In the adjacent figure A, B and C are three points. They are read as point A, point B and point C.

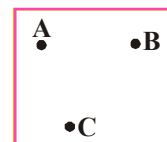

Do This

- Four points are marked in the given rectangle. Name them.



4.3 A LINE SEGMENT

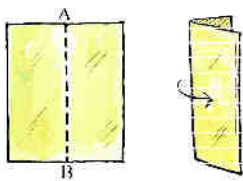

Take a thick paper and fold it as shown in figure. Look at the folded edge of this paper. It gives us an idea of what a line segment is. The crease left on the sheet represents a line segment. It has two end points named A and B. A line segment has negligible thickness.

Take your note book or a pencil box and draw a line along its edge with a pencil on a sheet of paper. What you have drawn is a representation of a line segment. It has two ends. Name them.

Take a thread. Stretch it. In this position it gives an idea of a line segment where the ends of the thread are the end points of the line segment.

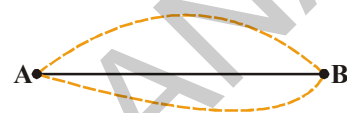

Mark any two points A and B on a sheet of paper. Join them in as many ways as you like. What is the smallest distance from A to B. This is a line segment AB and is denoted by \overline{AB} or \overline{BA} .

4.4 A LINE

Imagine that the line segment from A to B (i.e. \overline{AB}) is extended beyond A in one direction and beyond B in the other direction without any end.

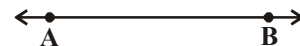

You now get a representation of a line.

Since we cannot draw an indefinitely long line, we mark arrow notations on both sides to show that it will go on. This line is denoted by \overleftrightarrow{AB} . It is also denoted by lower case letters such as l, m, n etc. This is also called as straight line.

Do This

Take a geo-board. Select any two nails and tie a thread tightly from one end to the other. The thread you have fixed is a line which can extend in both directions and only in these two directions.

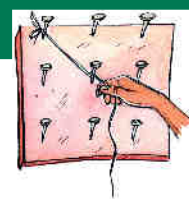

4.5 A RAY

Sun rays, light rays, rays from a torch are some examples of the Geometrical idea of a 'ray'.

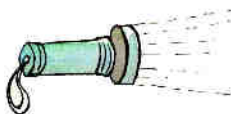

A ray is a part of a line. It begins at a point (initial point) and goes on endlessly in a specified direction.

Thus a ray has only one end point.

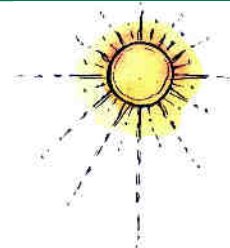

Let A be a point on a line. B and C are two points on the same line on either side of A.

Then \overrightarrow{AB} and \overrightarrow{AC} are two rays.



THINK, DISCUSS AND WRITE

Here is a ray \overrightarrow{OA} . It starts at O and passes through points A and B.

Can you name ray \overrightarrow{OA} as \overrightarrow{OB} ? Why?



Can you write the ray \overrightarrow{OA} as \overrightarrow{AO} ? Why? Give reasons.



EXERCISE - 4.1

1. Join the points given below. Name the line segments so formed in the figure.

(i) A



ii.



2. Name the following from the figure.

i) Any five points

ii) Any five line segments

iii) Any Three rays

iv) Any two lines.

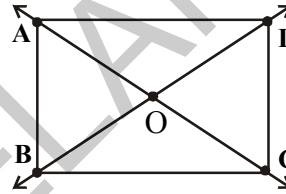

3. How many lines can be drawn through the points given below and make a rough figure for your answer.

i) One point

ii) Two distinct points

4. Which of the following has a definite length?

i) Line

ii) Point

iii) Line segment

iv) Ray

5. How many end points do the following have?

i) Line segment

ii) Ray

iii) Line

6. Write 'True' or 'False'.

i) A line has no end points.

()

ii) Ray is a part of a line.

()

iii) A line segment has no definite length.

()

iv) A line segment has only one end point.

()

v) We can draw many lines through a point.

()

7. Draw and name:

i) Line containing point P.

4.6 CURVE

Have you seen drawings of kids? Here are some examples.

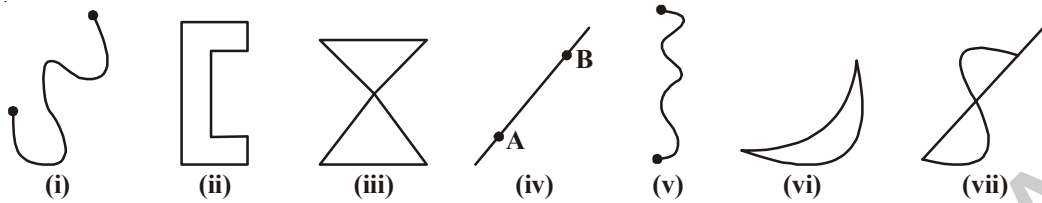

These are all examples of curves.

Observe figure (i) and (ii) what is the difference between them? Figure (ii) is called a closed curve and figure (i) is called an open curve.

Also observe that the curves (iii) and (vii) cross themselves, which are not closed curves where as (i), (ii), (iv), (v) (vi) do not cross. Which are called simple curves.

In every day language, curve usually does not refer to a straight line. But in mathematics a straight line is also curve.

THINK, DISCUSS AND WRITE

1. Move your pencil along the following english letters and state which are open and which are closed.



2. Tell which letter is an example of simple curve.



TRY THESE

Identify which are simple curves and which are not?

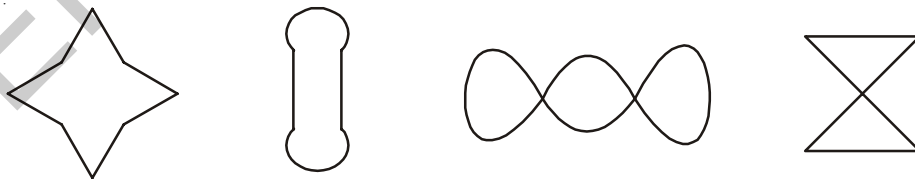

POLYGONS

Look at these following figures:

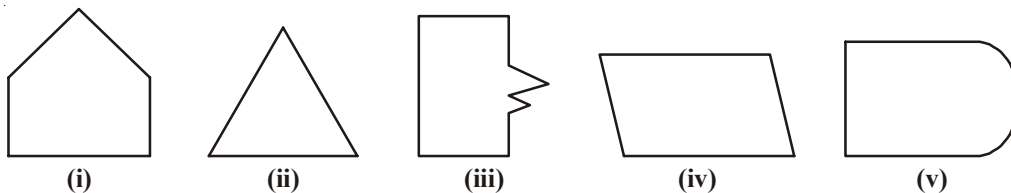

What can you say about them? Are they closed? How does each of them differ from one another? (i), (ii), (iii) and (iv) differ from (v), because they are made up of definite number of line segments. They are called **Polygons**.

So a figure is a polygon if it is a simple closed figure made up of definite number of line segments.

Draw ten polygons of different shapes.

Boundary wall of a park divides the park into three parts i.e. (i) inside the park, (ii) the park boundary wall and (iii) outside the park. You can't enter the park without crossing the boundary.

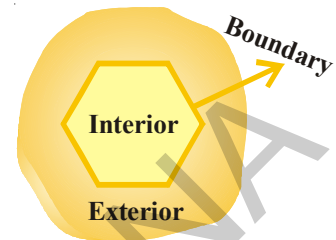

Likewise, a closed figure separates the plane into three parts.

- i) Interior (inside) of the Figure
- ii) Boundary of the Figure
- iii) Exterior (out side) of the Figure

The interior of the Figure together with its boundary is called its **region**.



EXERCISE - 4.2

1. Tick the figures which are simple curves.

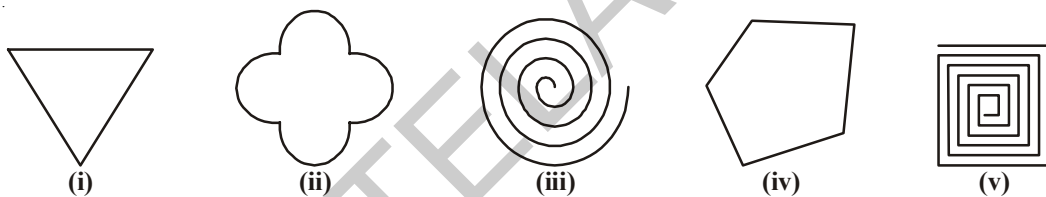

2. State which curves are open and which are closed

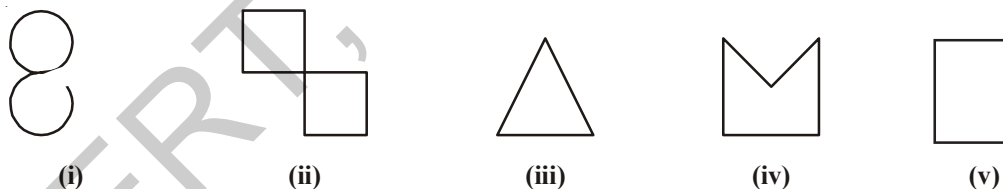

3. Name the points that lie in the interior, on the boundary and in the exterior of the figure.

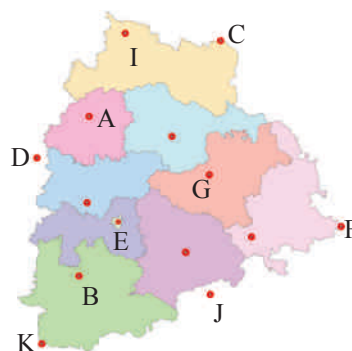

4. Draw three simple closed figures:
 i) by straight lines only ii) by straight lines and curved lines both

4.7 ANGLE

Observe the picture

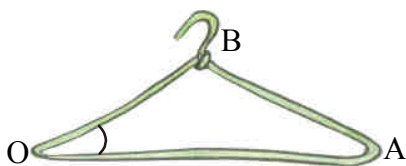

Figure - 1



Figure - 2



Figure - 3

Angles are made when corners are formed. In the figure - 1 imagine two rays say \overline{OA} and \overline{OB} . These two rays have a common end point at O. The two rays here are said to form an angle.

Look at the door in Figure-3. When it is closed it does not seem to make any angle with the threshold. As we start opening it there is an angle between the door and the threshold. It also changes as the position of the door changes. Here two rays can be imagined in the direction of the door and the threshold.

Observe how angles are formed between two hands of a clock at different time.



The two rays forming an angle are called the arms or sides of the angle. The common end point is called the vertex of the angle.

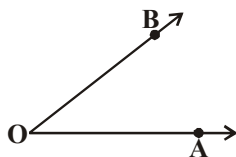

Here the two rays \overline{OA} and \overline{OB} are two **arms** or sides of the angle and O is the **vertex** of the angle. As the angle is formed at 'O', we read it as angle AOB or angle BOA and it is denoted by $\angle AOB$ or $\angle BOA$ (sometimes $\angle AOB$ or $\angle BOA$) or simply $\angle O$.

In the figure, point X is in the interior of the angle. Z is in the exterior part of the angle. Point S is on the arms of the angle $\angle PQR$.

So angle divides the plane into three parts, interior (bounded by the two sides), angle and the exterior (which is outside the angle).

Now think about point Y. Where does it lie?

If you extend the rays \overline{QP} and \overline{QR} , will point Y fall in the interior of the angle?

Is it possible to mark a point "M" in the interior of the angle by extending the rays?

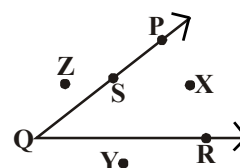

EXERCISE - 4.3

1. Name the angles, vertex and arms of the angles from the figure.

	i	ii	iii	iv
Angle	$\angle AOB$			
Vertex	O			
Arms	$\overline{OA}, \overline{OB}$			



2. Name the angles formed in the figure.

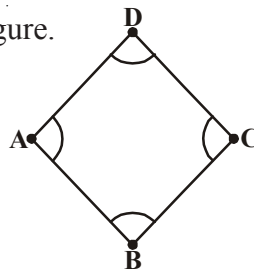

3. Mark the points in the figure which satisfy all the three conditions.

- i) A, B in the interior of $\angle DOF$
- ii) A, C in the exterior of $\angle EOF$
- iii) B on $\angle DOE$

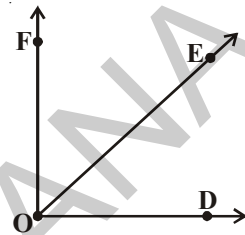

4. In which of the following figures, angles are formed?

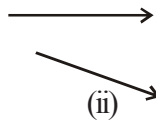
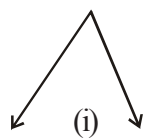

4.8 TRIANGLE

Do THIS

Take some match sticks and try to make simple figures. Identify closed figures in them.

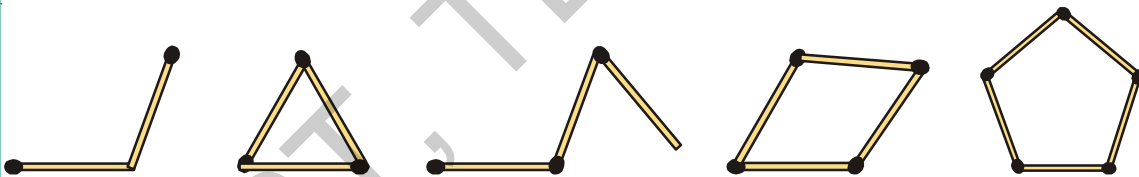

What is the least no. of sticks needed to form a closed figure? Obviously three. Can you explain why two match sticks can not make a closed figure?

The simple closed figure formed by three line segments is a triangle. The line segments are called sides.

Look at the triangle formed by three line segments \overline{AB} , \overline{BC} and \overline{CA} . Here A, B, C are called three vertices of the triangle ABC. You know that the angles $\angle BAC$, $\angle ABC$, $\angle ACB$ are formed at the vertices. The triangle ABC is denoted simply as $\triangle ABC$.

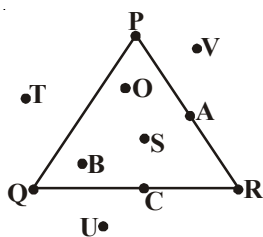
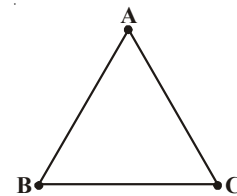

Being a polygon, a triangle has an exterior and an interior region.

Observe the triangle and points marked in the figure.

O is in the interior of the triangle. What are the other points in the interior?

P is a point on the triangle. Name the other points lying on the boundary of the triangle.

T is in the exterior of the triangle. What are the other points in the exterior?

Therefore, a triangle divides a plane into three parts.

(i) Interior of the triangle; (ii) Boundary of the triangle; (iii) Exterior of the triangle.

The boundary and interior of the triangle together is called triangular region.

DO THIS

Take some straw pieces of different size. Pass thread into any 3 pieces and make different triangles. Draw figures for the triangles in your notebook.

4.9 QUADRILATERAL

Observe the polygons in the adjacent figure. You know that a polygon with three sides as in Fig (i) is a triangle, similarly a simple closed polygon with four sides is called a quadrilateral. Fig. (ii) is an example for quadrilateral.

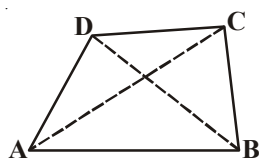
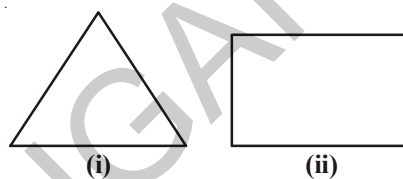

Here ABCD is a quadrilateral and the four line segments \overline{AB} , \overline{BC} , \overline{CD} and \overline{AD} are called its four sides, $\angle A$, $\angle B$, $\angle C$ and $\angle D$ are its four angles and the line segments joining opposite vertices A, C and B, D namely \overline{AC} and \overline{BD} , are called its two diagonals.

As in a triangle, quadrilateral drawn on a plane, divides it into three parts known as (i) interior, (ii) boundary and (iii) exterior of the quadrilateral.

The shaded part of the quadrilateral is its interior and the unshaded part is the exterior of the Quadrilateral.

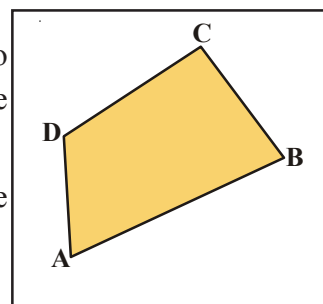

The side opposite to \overline{AB} is \overline{DC} .

What are the sides opposite to \overline{BC} , \overline{CD} and \overline{AD} ?

The side \overline{AB} is adjacent to \overline{BC} and \overline{AD} .

Name the adjacent sides of \overline{BC} , \overline{CD} and \overline{AD} .

Opposite angles are $\angle A$ and $\angle C$. What is the other pair of opposite angles?

The adjacent angle of $\angle A$ is $\angle B$ and $\angle D$. What are the other pairs of adjacent angles.

THINK, DISCUSS AND WRITE

Take four points A, B, C and D such that A, B, C lie same line and D is not on it. Can the four line segments \overline{BC} , \overline{CD} and \overline{AD} form a quadrilateral? Give reason.

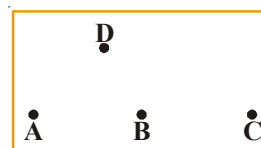



EXERCISE - 4.4

- Mark any four points A, B, C and D. Join them to make a quadrilateral. Name it.
- PQRS is a Quadrilateral. Answer the following.
 - The opposite side of \overline{QR} is _____.
 - The angle opposite to $\angle P$ is _____.
 - The adjacent sides of \overline{PQ} are _____.
 - The adjacent angles of $\angle S$ are _____.
- Name the points marked in the figure
 - The points in the interior of Quadrilateral.
 - The points on the boundary of Quadrilateral.
 - The points in the exterior of the Quadrilateral.

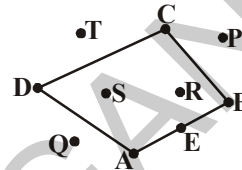
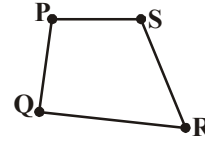

4.10 CIRCLE

Look at the figures



Keep a bangle on a paper and draw along its boundary with pencil. You get a round shape. This will give you an idea of a circle. Such a round shaped figure is a circle. Can you think of some more examples from real life?

Observe a cycle wheel and measure the length of each spoke. You might conclude that the length of each spoke is same. The point in the middle is the **centre** and the length of curved edge is called **circumference** and the distance from the centre to any point on the circle is the **radius**.

Observe the centre and each radius in the circle given in the figure.

Are all the radii same? O is the centre and \overline{OA} , \overline{OB} and \overline{OC} are radii of the circle.

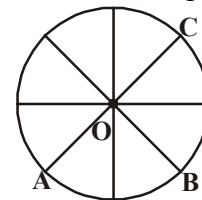

DO THIS

Draw a circle on a paper and cut it along its edge. Fold it into half and again fold it to one fourth to make folding marks as shown.

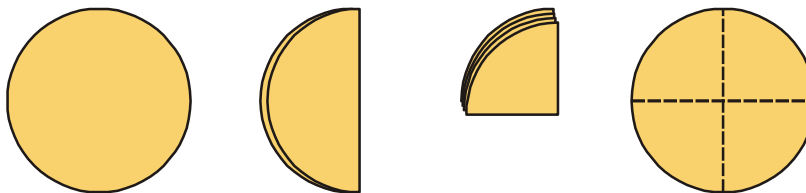

You will observe a point in the middle. Mark this O. This is the centre of the circle. You can also indicate its radius. How many radii can you draw in a circle?

\overline{AC} is a line segment joining any two points on the circle.

Is there any other such line segment which joins two points on the circumference? \overline{CD} is one such line segment. A line segment joining two points on the circumference of the circle is called a **chord**. Thus both \overline{AC} and \overline{CD} are chords of the circle. The chord \overline{AC} is a special chord as it passes through the centre 'O'. A chord which passes through the centre of a circle is called **diameter**.

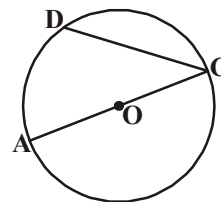

DO THIS

Draw a circle and draw at least 5 chords in it. Make sure at least one of them passes through the centre. Name them and fill the table

S.No.	Chord	Length	Passes through the centre (Yes/No)
1.			
2.			
3.			
4.			
5.			

What do you notice?

You must have noticed that the chord passing through the centre is the longest.

Let us go back to the figure, \overline{AC} is a line segment whose mid-point is at O.

Also, we know that \overline{OA} and \overline{OC} are two radii of the circle.

Thus, we can see that length of \overline{OA} + length of \overline{OC} = length of \overline{AC} .

Diameter is twice the radius of the circle.

THINK AND DISCUSS

Is it possible to draw more than one diameter in a circle? Are all the diameters equal in length? Discuss with your friends and find the answer.

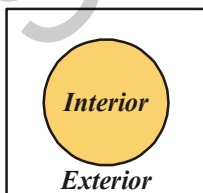

Look at the figure again. The part of the circle between the points C and D is called an **arc** and denoted by \widehat{CD} .

Name the other arc in the figure.

As a circle is a simple closed figure, it divides the plane with its boundary as interior and exterior.

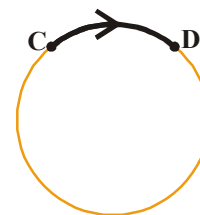

The region in the interior of a circle enclosed by the boundary is called **circular region**.

Some other parts of the circle

Region enclosed by an arc and two radii is called **sector of the circle**.

Region enclosed by an arc and a chord is called **segment** of a circle. Chord of a circle divides it into two segments.

Region enclosed by an arc and a diameter is called a **semi circle**.

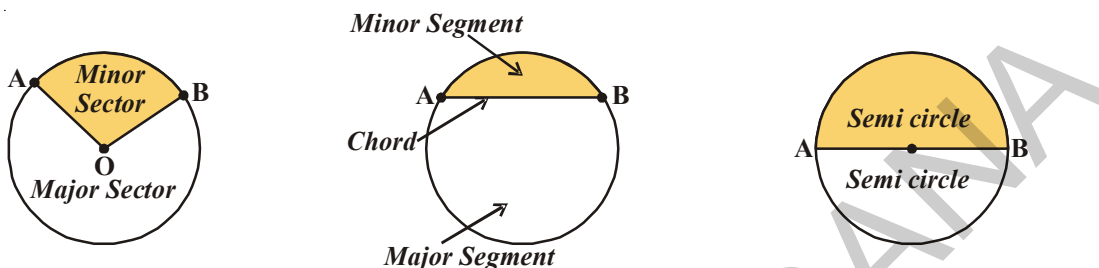

EXERCISE - 4.5

1. Draw a circle and name its centre, a radius, a diameter and arc.
2. Shade the regions in the circle
 - i) Sector with red
 - ii) Minor segment with yellow
3. Say 'True' or 'False'
 - i) We can locate only one centre in a circle ()
 - ii) Diameter is twice the radius ()
 - iii) An arc is a part of a circle ()
 - iv) All chords are equal in length ()
 - v) All radii are not equal in length in a circle ()
4. Take a circular sheet of paper. Fold it into two halves. Press the fold and open it. Do you find the crease of a diameter? Repeat the same activity by changing the fold. How many diameters do you observe? How many more diameters can be formed?

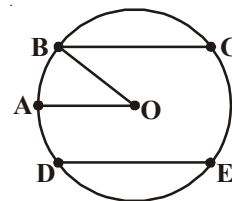

WHAT HAVE WE DISCUSSED?

1. A point determines a location. It is usually denoted by a capital letter.
2. A line segment is formed by joining two points. It has a fixed length.



3. A line is obtained when a line segment extends on both sides indefinitely.
4. A ray is a part of a line starting at a point and goes in one direction endlessly.
5. Any figure drawn without lifting a pencil may be called a curve. In this sense, a line is also a curve.
6. A simple curve is one that does not cross itself.
7. Curves are of 2 types- open and closed.
8. An angle is made up of two rays starting from a common end point. The common end point is called vertex and the two rays are arms of the angle.
9. Every angle divides the plane as interior, exterior and boundary of the angle.
10. A triangle is a simple closed figure bounded by three line segments.
11. A triangle has three vertices, three sides and three angles.
12. A triangle with its boundary and interior is called the triangular region.
13. A quadrilateral is a simple closed figure bounded by four line segments. It has four vertices, four sides, four angles and two diagonals.
14. A circle is simple closed curve, where each point on the boundary is at an equal distance from the centre. The fixed distance is the radius.
15. A part of a circle is an arc and the total length of the circle is called its circumference.
16. A chord of a circle is a line segment joining any two points on the circle. Diameter is also a chord.
17. A diameter of a circle is double the radius.
18. A circle with its boundary and interior together is a circular region.
19. The region in a circle bounded by two radii and the arc is called sector.
20. The region in a circle bounded by a chord and the arc is called a segment of the circle.
21. Each diameter divides a circle into two semicircles. A semi circle is half of the circle.

Euclid (Greece)

365 BC

He was a famous Greek philosopher and mathematician. He has introduced geometry in a logical order in the book, 'The Elements'. His geometry is known as Euclidean geometry.





5.1 INTRODUCTION

In the chapter 'Basic Geometrical Ideas', we learnt about some geometrical shapes. These included lines, angles, triangles, quadrilaterals and circles. Many of these are made of line segments and angles formed by them. We can see that in these shapes, lines and angles have different sizes. We can often compare the lengths of line segments and the measures of angles between them by looking at them.

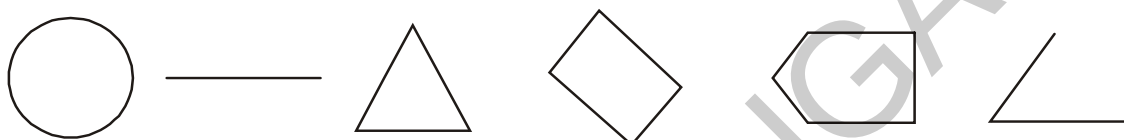

fig. 5.1

This is not however possible all the times. Some times the measures are so close to each other that we require an accurate tool/device to measure these measurements. In this chapter, we are going to learn how to measure the line segments and angles.

5.2 MEASURE OF A LINE SEGMENT

The edges of a book, TV screen, bricks etc. are like a line segment drawn through any edge.

We have seen and also drawn so many line segments.

We know that a triangle is made of three and a quadrilateral of four lines segments.

A line segment is a part of a line with two end points. This makes it possible to measure a line segment. This measure of each line segment is its "length". We use length to compare line segments.

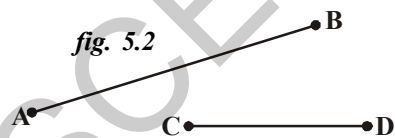

fig. 5.2

We can compare the 'length' of two line segments in three ways:

- Simple observation.
- Tracing on a paper and comparing.
- Using instruments.

The line segments \overline{AB} and \overline{CD} in the figure 5.2 can be compared by simple observation. Can you find the longer one?

By simple observation, we can say that \overline{AB} is clearly longer than \overline{CD} .

But it is difficult to compare the lengths of the another two pairs \overline{AB} , \overline{CD} and \overline{PQ} , \overline{RS} shown in the figure 5.3. Why?

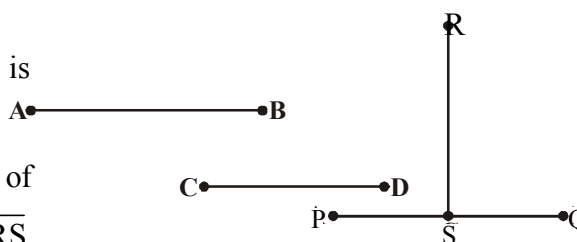

fig. 5.3

THINK AND DISCUSS

How do we compare them?

To compare them, we trace the line segments \overline{AB} and \overline{CD} on a tracing paper such that they are roughly aligned in the same direction. Do their end points coincide?

We can now say \overline{AB} is longer than \overline{CD} . In the same way we can compare \overline{PQ} with \overline{RS} . We can see \overline{PQ} and \overline{RS} are of equal length.



5.2.1 COMPARING BY USING INSTRUMENTS

To compare any two line segments accurately, then we need proper instruments. These include the ruler (scale) and divider in the Geometry box.

Have you seen and used these instruments? Look at these carefully.

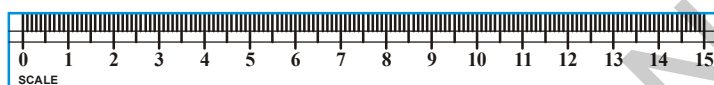

Ruler Fig. 5.4

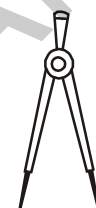

Divider

A ruler (scale) is divided into 15 big parts as marked along one of its edges. Each of these 15 parts is of length 1 centimeter (1 cm.) Each centimeter is divided into 10 equal parts again and each sub part is 1 millimeter (1 mm.)

Let us see how to measure the length of a line segment using the ruler.

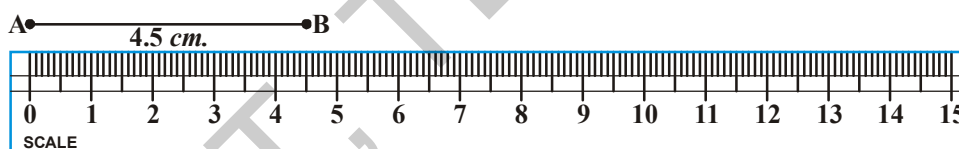

Place the zero mark (cm.) of the ruler at A. Read the mark against B. This gives the length of AB line segment.

Here length of $AB = 4.5$ cm.

i.e. $AB = 4.5$ cm.

Note: Let us assume that we place the 1 cm mark of the ruler at A. Then the mark against B would be 5.5 cm. Then we need to read both the points and subtract to find the length. i.e. $5.5 - 1 = 4.5$ cm.

THINK, DISCUSS AND WRITE

What other errors can you find while measuring the length of line segment?

For example, to find the length of a pencil, the eye should be correctly positioned as shown in the figure i.e. just vertically above the mark for both points. Other wise there may be an error due to angular viewing.

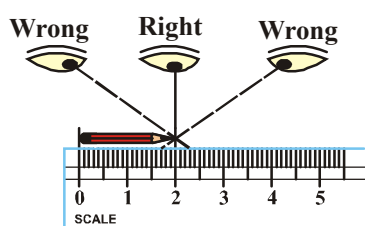

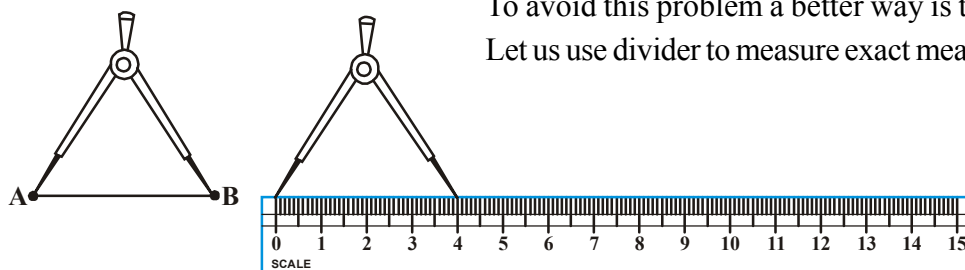

fig. 5.5

Open the divider. Place the end point of one of its arms at 'A' open it till the end point of the second arm is placed at B. Lift the divider carefully without disturbing the opening of the divider place it on the ruler. Read the marks against each end point.

What is the length of line segment AB?

Take more line segments. Measure their lengths.



TRY THESE

1. Take a post card and measure the length and breadth with ruler and divider. Do all post cards have the same dimensions?
2. Select any three objects like eraser, small pencil, etc. Trace their length on a paper. Measure the length of these line segments.



EXERCISE - 5.1

1. Give any five examples of line segment observed in your classroom.
Eg.: edge of black board.
2. It is better to use a divider than a ruler, while comparing two line segments why?
3. Measure all the line segments in the figure given below and arrange them in the ascending order of their lengths.



Line Segments \overline{AB} , \overline{AC} , \overline{AD} , \overline{AE} , \overline{BC} , \overline{BD} , \overline{BE} , \overline{CD} , \overline{CE} , \overline{DE}

4. Mid point of \overline{AB} is located by Swetha and Reshma like this.

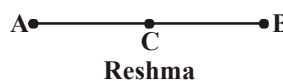
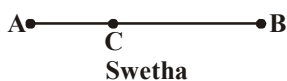

Which one do you feel correct? Measure the lengths of \overline{AC} , \overline{CB} and verify.

5. Each of the figures has many line segments. For the almirah we have shown one line segment along the longer edge. Identify and mark all such line segments in these figures.



5.3 MEASURE OF AN ANGLE

We see angles around us all the time.

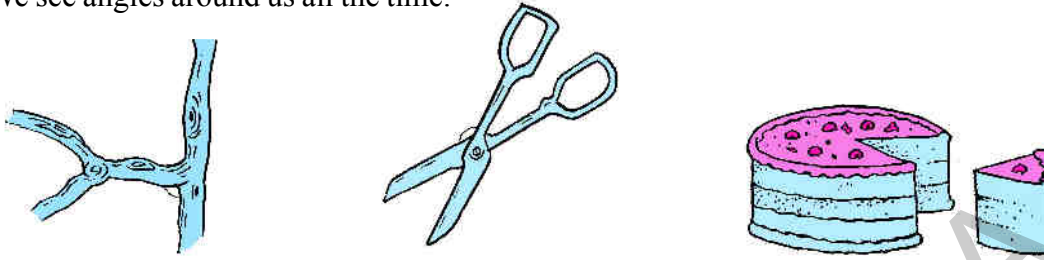

We know as the line segments of the blade of scissors move further apart, the measure of the angle between them increases. Angle is formed between two rays or two line segments. Give some examples of things where we can see angles.



ACTIVITY

Look at the following figures:



Put your hands close to your body. Keep one hand in the same position and slowly move up the other hand. As you go on moving your hand; you can observe the angle between your body and moving hand changes.

Let us consider the different angles formed and what we call them.

In figure (iii) your arm is perpendicular to your body. The angle formed by your arm with your body is exactly 90° which is called a right angle.

In figure (ii) the angle formed between your body and hand is less than a right angle. Such angles are called acute angles.

In figure (iv) the angle formed is more than a right angle and it is called an obtuse angle.

In figure (v) your hand is again along your body and the angle formed is 180° . This is called a straight angle.

Now, in fig.(i) do you find any angle between your hand and your body?

There is no angle formed. So here we say that it is zero angle and we started moving from zero angle. Notice the figures are now pointing up and not down. This indicates that we have not reached the initial position.

Let us observe some other angles formed between the hands in a clock.

If we take, the angle between the hands to be zero at 12'O clock.



(i)



(ii)

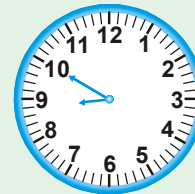

(iii)

1. Which clock's hands are showing acute angle?
2. In which figures the clock's hands form an obtuse angle?

These angles would be measured using the small i.e. hours hand as a base and we will measure the clockwise movement of the minutes hand away from the hour's hand.



ACTIVITY

Take two straws

Keep one end of the one straw over the other straw end and fix a pin at that point as 'L' shape. Here you find a right angle tester (fig. 5.6).

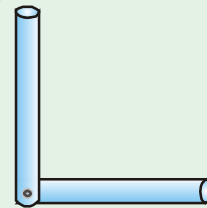

fig. 5.6

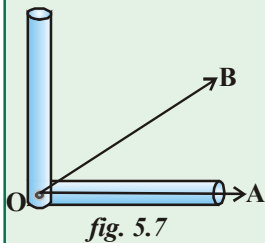

fig. 5.7

Keep the tester on one ray \overline{OA} coinciding with vertex as shown in the (fig.-5.7). Now $\angle AOB$ is less than the right angle. Thus it is an acute angle.

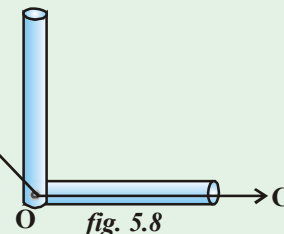

fig. 5.8

Keep the tester on one ray \overline{OC} coinciding with the vertex as shown in the (fig.-5.8). Now $\angle COD$ is more than the right angle. Thus it is an obtuse angle.



TRY THESE

1. Use the 'right angle tester made of straws' and identify the following angles.

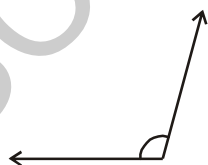

(i)

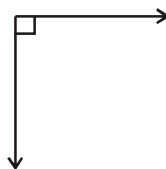

(ii)



(iii)

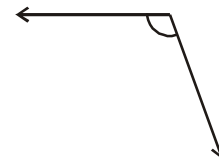

(iv)

2. List out five daily life situations where you observe acute angles and obtuse angles.
3. Draw some angles of your choice. Test them by the 'angle tester' and write which are acute which are obtuse and which are right angles.

Satya and Swetha were given Ray \overline{OA} and were asked to draw 45° angle. They drew like this:

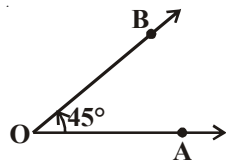

Satya ($\angle AOB = 45^\circ$)

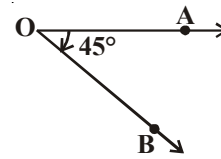

Swetha ($\angle AOB = 45^\circ$)

What is the difference in the angles drawn by Satya and Swetha?

In the angle made by Satya, \overline{OA} moved in the opposite direction of the hands of a clock and reached \overline{OB} , making an angle of 45° . Such **angles where the ray moves in the opposite direction of the hands of a clock are called Anti clock-wise angles**. The anti clock-wise angles are denoted by a positive measure. So Satya's angle is 45° .

In the angle made by Swetha, \overline{OA} moved in the direction of the hands of a clock and reached \overline{OB} , making an angle of 45° . Such **angles where the ray moves in the direction of the hands of a clock are called clock-wise angles**. They are denoted by negative sign. The angle made by Swetha is of -45° .

THINK, DISCUSS AND WRITE

In the adjacent figure $\angle AOB$ and $\angle AOC$ are given. Which angle is clock-wise and which angle is anti clock-wise. Think and discuss with your friends.

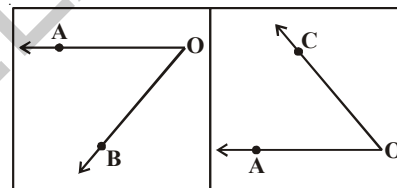

ACTIVITY

- Cut out a circular shape using a bangle or take a circular sheet.
- Fold it once from the middle, you will get a semi circle.
- Fold it once again to get a shape as shown. This is called a quadrant.
- The fold is at 90° to the edge. Mark 90° on the fold.
- Now fold the quadrant once more as shown. The angle is half of 90° i.e. 45° . Open it out now. What is the angle upto the new line? Mark 45° for the angle formed between crease and the baseline. Mark the measure of the fold on the other side of 90° as 135° , since $90^\circ + 45^\circ = 135^\circ$.

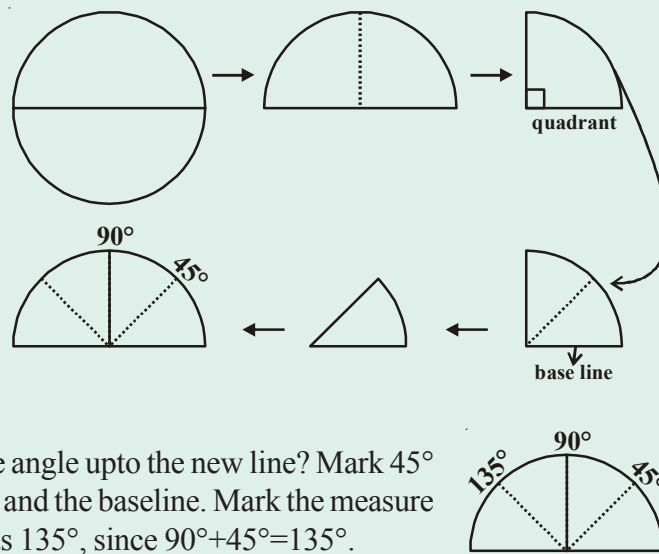

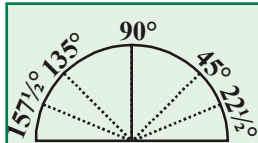

6. Fold the paper again upto 45° (half of the quadrant). Now make half of this. The first fold to the left of the base line now is half of 45° i.e. $22\frac{1}{2}^\circ$. The angle on the left of 135° would be $157\frac{1}{2}^\circ$.

You have got a ready device to measure angles. This is an appropriate protractor.

5.3.1 THE PROTRACTOR

The improvised 'Right angle tester' we made is helpful to compare angles with a right angle. But this does not give a precise comparison. So in order to compare and measure angles more precisely we need an instrument, which is '**a protractor**'.

If you look at the protractor carefully, it is in the shape of semicircle, the line drawn along with the diameter is the base, A line drawn perpendicularly to the base is marked as 90° . The meeting point of base to perpendicular line is called the centre. Along with the arc, 0° to 180° were marked both in clock wise and anticlockwise directions.

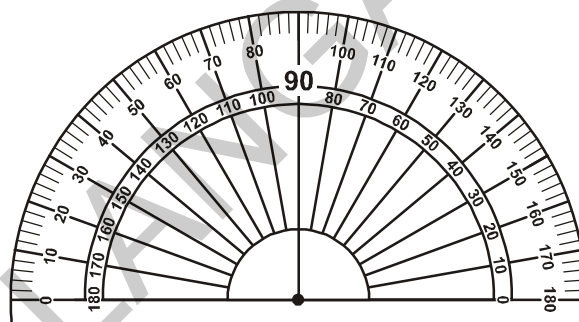

Anticlockwise angles are called inner scale, and clockwise angles are called outer scale. 180 equal parts on outer scale has been marked to represent 0° to 180° . It is divided into 180 equal divisions and each division is called a degree (1°). These divisions on the curved edge are at a gap of 10° . A line joining the zeros (0°) on either side that passes through the centre point is a Base line.

Now, you will learn how to use the protractor to measure an angle.

Clockwise Angle	Steps	Anti-clockwise Angle
 	<ol style="list-style-type: none"> 1. Identify the angle which is acute or obtuse. 2. Place the centre point of the protractor on the vertex of the angle. 3. Adjust the protractor (without shifting the centre point from the vertex) So that one arm of the angle is along the base line. 	

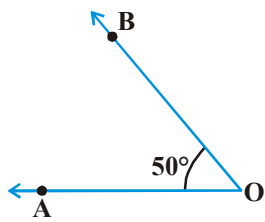

4. Look at the scale where the base line points to 0° .

5. Read the measure of this angle, where the other arm crosses the scale thus $\angle AOB = 50^\circ$

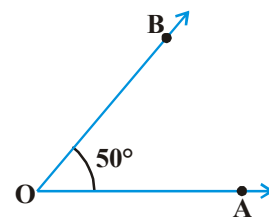

Read the following table:

Type of Angle	Measure
Zero angle	0°
Right angle	90°
Straight angle	180°
Complete angle	360°
Acute angle	between 0° and 90°
obtuse angle	between 90° and 180°
Reflex angle	between 180° and 360°



TRY THESE

1. Which angle is greater? Discuss with your friends.

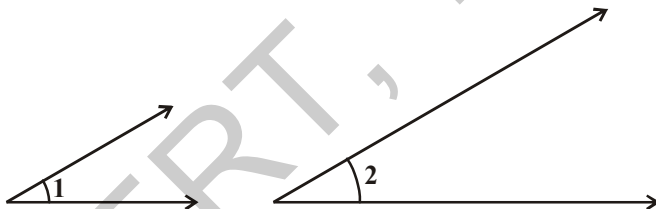

Verify by measuring the angles using protractor. Is your estimation is correct? Give reasons.

2. Which are acute angles? Find and write their measures.

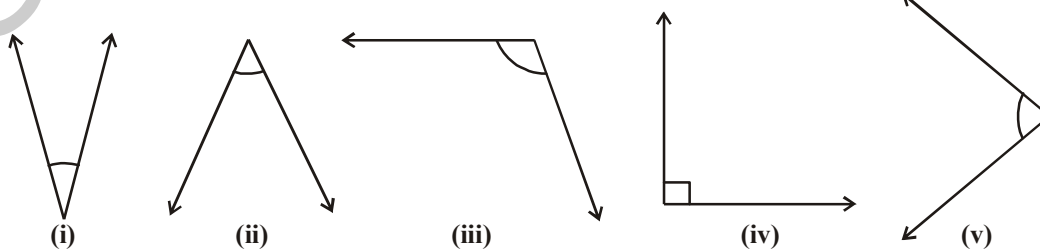

3. Which are obtuse angles?

(i) (ii) (iii) (iv) (v)

4. Draw any two acute and two obtuse angles of your choice.

5. Classify the following angles into acute, right, obtuse, straight and reflex angles:
 40° , 140° , 90° , 210° , 44° , 215° , 345° , 125° ,
 10° , 120° , 89° , 270° , 30° , 115° , 180°

EXERCISE - 5.2

- Write 'True' or 'False'. Correct all those that are false.
 - An angle smaller than right angle is acute angle ()
 - A right angle measures 180° ()
 - A straight angle measures 90° ()
 - The measure greater than 180° is a reflex angle. ()
 - A complete angle measures 360° . ()

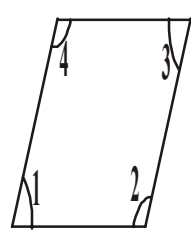

- Which angles in the adjacent figure are acute and which are obtuse? Check your estimation by measuring them. Write their measures too.
- What is the measure of these angles. Which is the largest angle? Draw an angle larger than the largest angle.

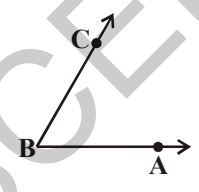

$\angle ABC = \dots\dots\dots$

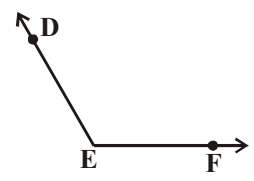

$\angle FED = \dots\dots\dots$

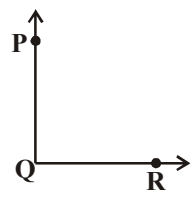

$\angle RQP = \dots\dots\dots$

- Write the type of angle formed between the long hand and short hand of a clock at the given timings. (Take the small hand as the base)
 - At 9 'O' clock in the morning
 - At 6 'O' clock in the evening
 - At 12 noon

5. Match the angles by measure. Draw figures for these as well.

Group A	Group B
Acute angle	90°
Right angle	270°
Obtuse angle	45°
Reflex angle	180°
Straight angle	150°

5.4 INTERSECTING LINES, PERPENDICULAR LINES AND PARALLEL LINES

5.4.1 INTERSECTING LINES

Look at the following pictures.



We can see that the roads and sticks can be represented by lines. The lines drawn in the pictures represent a pair of intersecting lines. These lines have a common point.

How many common points two distinct lines can have?



TRY THESE

1. Draw any two separate lines in a plane. Do they intersect at more than one point?
2. Can you think of distinct lines that have three common points? Two common points?

Two separate lines l and m meet each other at a point P . We say l and m intersect at P . This is the only common point that these lines can have. **If two lines**

have a common point, they are called intersecting lines.

Think about lines that have no common point what would these lines be like?

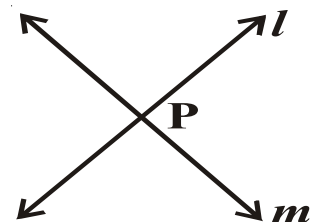

5.4.2. PERPENDICULAR LINES

- Angles are made by lines that intersect. Look at the intersecting lines below. They all form many angles. Identify all the angles formed by the intersecting lines.

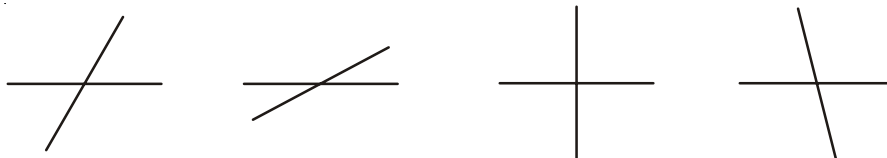

Some of these angles are obtuse, some are acute and some are right angles.

- Observe the lines formed between the edges of the figures.

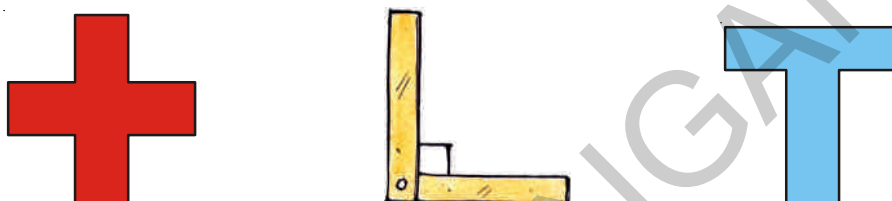

Imagine the lines in the figures.

Do they make a right angles? Do they intersect each other?

If two lines intersect each other at right angle, then the lines are perpendicular.

Here a line ' l ' is perpendicular to a line ' m ' we write it as $l \perp m$.

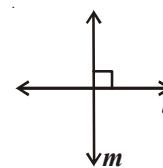

THINK, DISCUSS AND WRITE

- If $l \perp m$, then can we say that $m \perp l$?
- How many perpendicular lines can be draw to a given line?
- Which letters in English alphabet possess perpendicularity?



5.4.3 PARALLEL LINES

Observe the Figures:

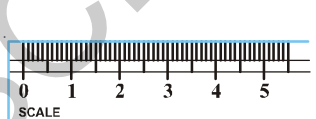

Imagine the edges of scale, railway track, electrical wires. What is special in these pairs of lines? Would they meet if we extend them without changing direction.

If two lines on a plane do not intersect each other at any point, they are called parallel lines. Here l and m are parallel lines. We write it as $l \parallel m$ and read it as l is parallel to m .

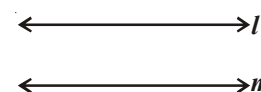

Can you find some more examples of parallel lines in the



TRY THESE

Draw two lines on a paper as shown in the figure. Do they intersect each other? Can you call them parallel lines? Give reason.

Make a pair of parallel lines what is the angle formed between them? Think, discuss with your friends and teacher.

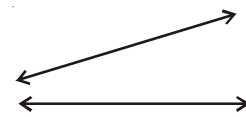

EXERCISE - 5.3

- Which of the following are models for parallel lines, perpendicular lines and which are neither of them.
 - The vertical window bars
 - Railway lines (track)
 - The adjacent edges of door.
 - The letter 'V' in English alphabet
 - The opposite edges of Black Board.
- Trace the copy of set squares (Geometry box) on a paper and mark the perpendicular edges.
- ABCD is a rectangle. \overline{AC} and \overline{BD} are diagonals. Write the pairs of parallel lines, perpendicular lines from the figure in symbolic form. Also write pairs of intersecting lines.

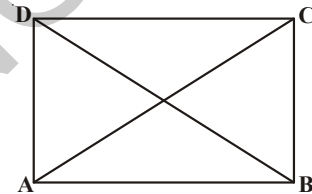

WHAT HAVE WE DISCUSSED?

- We compare two line segments by simple observation, by tracing the segments and by using instruments.
- The instruments used to compare and draw line segments are ruler and divider.
- Length is measured in cm and mm. $1 \text{ cm} = 10 \text{ mm}$.
- A protractor is a semi circular curved model with 180 equal divisions used to measure and construct angles. Each division is called 1 degree (1°).
- The unit of measuring an angle is a degree (1°). It is $\frac{1}{360}$ th part of one rotation.
- The measure of right angle is 90° and that of straight angle is 180° .
- An angle is **acute** if its measure is smaller than that of a right angle.
- An angle is **obtuse** if its measure is more than that of a right angle and less than a straight angle.
- An angle is **reflex** if its measure is more than a straight angle and less than a complete angle.
- Two distinct lines of a plane which have a common point are **intersecting lines**.
- Two intersecting lines are **perpendicular** if the angle between them is a right angle.
- If two lines of a plane do not intersect each other then they are called parallel lines.
- Two parallel lines do not have any common point.





Integers

6

6.1 INTRODUCTION

Rafi gets ₹ 100 as pocket money from his father every month. He gives this money to his mother and takes some amount from her whenever he required. His mother makes a note of the money and he takes and gives in a book.

Rafi took ₹ 50 in the first week, ₹ 20 in the second week, ₹ 30 in the third week and wanted ₹ 20 in the last week. But Rafi's mother told him that he had taken the entire amount given to her. Rafi said that he would adjust the amount from next month's pocket money, but needs the money. She agreed and gave him ₹ 20 and recorded it as follows:

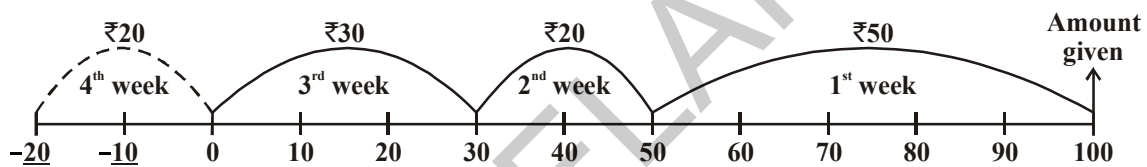

Record of the money in 1st Month

On the first day of the next month, Rafi got ₹ 100. He gave it to his mother. Can you say, how much money does Rafi have with his mother?

On the same evening his uncle gave him a tip of ₹ 50. He felt happy and gave the same to his mother to deposit, asking her to keep it and record the money. Can you find out, how much money did Rafi has with his mother then? Look at the record once again:

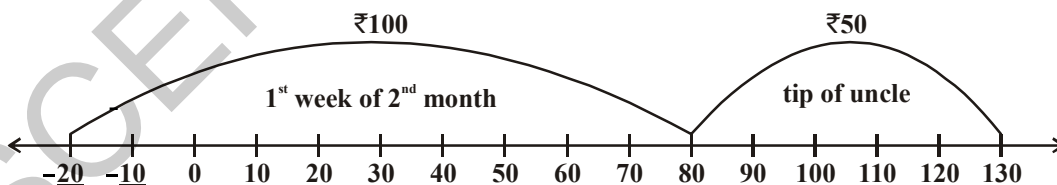

Record of 2nd Month

Now answer the following by observing the record:

1. How much money does Rafi's father give him as pocket money every month?
2. How much money did Rafi spend in four weeks?
3. How much money did Rafi's mother lend him in the fourth week?
4. How did she mark the money she lent in the last week?

- What is the difference between moving by ₹ 20 to the right of zero and by ₹ 20 to the left of zero?
- Which side of line she has marked the money when Rafi gave ₹ 100 and ₹ 50 in the next month?

6.2 HOW NEGATIVE NUMBER'S ARISE?

You would have realized that ₹ 20 marked on the either sides of zero do not mean the same. The numbers on the left of zero are negative numbers and are less than zero. The numbers on the right are positive and are greater than zero.

There are several situations in our daily life where we use these numbers to represent loss and profit, past and future, low and high temperatures etc. The numbers on the left side of zero (i.e. less than zero) are called negative numbers. These are denoted as -1, -2, -3,, -10, -20, ... for easy understanding.

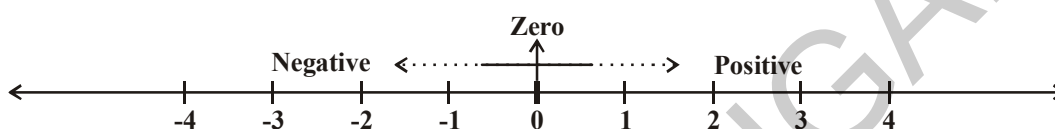

We use the negative numbers in our daily life as:

- The loss of ₹ 200 in a business is represented as (-200) and profit of ₹. 200 is represented as (+200)
- The temperature above 0°C is denoted as 'positive' and below 0°C is denoted as negative such as 3°C below 0°C is -3°C
 3°C above 0°C is $+3^{\circ}\text{C}$

DO THIS

Manasa has borrowed ₹ 50 and Swetha has borrowed ₹ 20 from their mother. How will you represent this on the number line? Suppose their father gave them ₹ 100 each as pocket money, who will have more money after clearing the debit?

6.3 SOME EXAMPLES OF NEGATIVE NUMBERS

Show the following using the ground level as zero with appropriate signs:

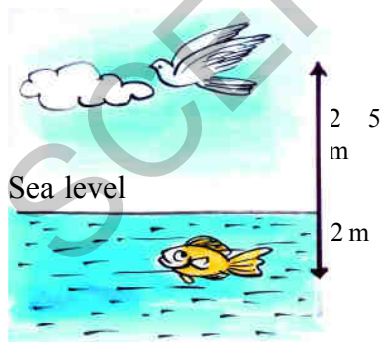

- A bird is flying at a height of 25 meters above the sea level and a fish at a depth of 2 meters.
- A flag is posted on top of a mountain at the height of 500m and another one placed on top of a tent made in the bed of a lake 25m below the ground.



- The temperature on a cold night in Delhi was 5°C and in Kufri in Himachal Pradesh was 6 degree below zero.

THINK, DISCUSS AND WRITE

Write some more models for positive and negative numbers in our daily life.



The numbers which are positive, zero and negative numbers together are called as 'Integers' and they are denoted by the letter 'Z' (I or Z).

$$Z = \{\dots, -3, -2, -1, 0, 1, 2, 3, \dots\}$$



TRY THESE

Collect information about temperatures recorded in various places in India in the month of January and write them using integers.

6.4 REPRESENTATION OF INTEGERS ON A NUMBER LINE

Now, Rafi understood how his mother is representing Integers on the number line.

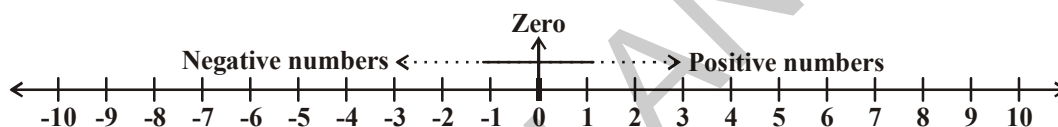

The numbers which are on the right side of zero are positive numbers (natural numbers) and which are on the left side of zero are negative numbers. Zero is neither positive nor negative. Do you agree? Why?

Now answer the following using number line:

1. Which is the nearest positive Integer to zero?
2. How many negative numbers you will find on left side of zero?
3. Which is greater (-2) or (-1)?
4. Which is smaller among 3 and -5? Why?
5. Which Integer is neither positive nor negative?



DO THIS

Draw a vertical line and represent the following Integers on the number line:

-5, 4, -7, -8, -2, 9, 5, -6, 2.



EXERCISE - 6.1

1. Represent the following statements using signs of Integers.
 - i) An aeroplane is flying at a height of 3000 meters ()
 - ii) The fish is 10 meters below the water surface. ()
 - iii) The temperature in Hyderabad is 35°C above 0°C. ()

- (iv) The average temperature at the mount Everest in January is 36°C below zero degree. ()
- (v) The submarine is 500 meters below the surface of the sea. ()
- (vi) The average temperature at Dargeeling in July is 19°C below zero degree. ()
- (vii) The average low temperature in Vishakapatnam during January is 18°C . ()
2. Write any five negative integers.
3. Write any five positive integers.
4. Mark the Integers on the number line given below: $-4, 3, 2, 0, -1, 5$
- 
5. Write True or False. If the statement is false, correct the statement.
- (i) -7 is on the right side of -6 on the number line. ()
- (ii) Zero is a positive number. ()
- (iii) 9 is on the right side of zero on the number line. ()
- (iv) -1 is an integer which lies between -2 and 0 . ()

6.5 ORDERING OF INTEGERS

Pavan and Harish are friends and they noticed that the water level in the well of their village reduces during summer and rises during the rainy season. The level is shown by the steps made. They used the idea of the number of steps of the well and prepared a model of the well using a glass jar. They pasted a strip showing integers with steps below zero as $-1, -2, -3$ and steps above zero as $1, 2, 3, 4$ and so on. They took zero as the level of water on the first day they observed.

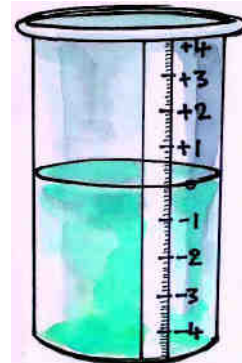

They use this jar to depict the water level, taking out water when water level fell in the well and adding water when it rose. They recorded the water level when above the base step level as positive and below it as negative. They got a record of the rise and fall of water. We will now study the water in the jar. Let us think.

1. What happens when water is poured into the jar?
2. What happens when water is removed from the jar from the zero level?

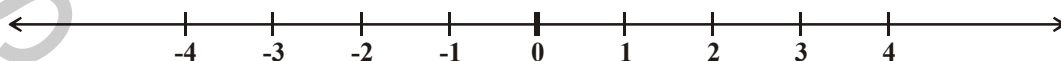

How does the position of the water level change on the strip? We show integers on strip placed horizontally. These are represented on the number line.

We know that $4 > 2$ and that 4 is to the right of 2 on the number line. Similarly, $2 > 0$ and is to the right of 0 . Now, since 0 is to the right of -3 , we say $0 > -3$.

Thus, we see that on a number line, the number increases as we move to right and decreases as we move to the left. Therefore, $-3 < -2$, $-2 < -1$, $-1 < 0$ and $0 < 1$, $1 < 2$, $2 < 3$ so on.



- (i) Go 7 steps up from the shop.
 - (ii) Go 3 steps down from the ground floor.
 - (iii) Go 5 steps up from the ground floor and then go 3 steps further up from there.
 - (iv) Go 4 steps down from the ground floor and then further 3 steps from there.
 - (v) Go down 5 steps down from the ground floor and 10 steps up from there.
 - (vi) Go 8 steps up from the ground floor and come down 9 steps down from there.
- Check your answers with your friend and discuss.

6.6 ADDITION AND SUBTRACTION OF INTEGERS

Play a Game

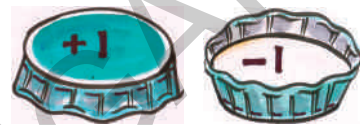
Take 10 identical caps of cool drink bottle. These bottle caps can be placed down words and upwards. Consider the top side of the cap to be (+1) and the bottom side to be (-1).



Ask your friend to throw 10 caps in a single move after shaking them vigorously. Look at the way the 10 caps lie. Which side of the cap is showing? Consider one up (+1) and one down (-1) to be a pair. Remove all the pairs like   i.e. (+1) and (-1). Are the remaining caps up or down? Count these caps. If there were 4 pairs made, two caps are left. As in the example below if these face up then it is +2 points.



If 3 pairs are formed and 4 caps are left facing down, then the points are '-4'.



Record the points in your note book using a number line. You can continue to play till any one of you get 10 points and wins the game.



Your record

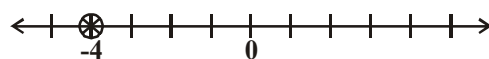

Your friend's record

Have you observed the number lines?

Does she move right or left on the line? Clearly she moves left two places starting from -4 and reaches -6 we say $(-4) + (-2) = -6$.

You add two positive integers like $(+3) + (+1) = 4$. You can also add two negative integers and the answer will take a minus sign (-) like $(-3) + (-2) = -5$.

What happens when we have one positive integer and one negative integer. Let us take the help of caps. Place as many caps facing up as positive integer and as many caps facing down as negative integer. Remove caps in pairs i.e. an up cap with a down cap since $(+1) + (-1) = 0$. Count the remaining caps.

Ex: (i) $(-3) + (+2) = (-1) + [(-2) + (+2)]$

$= -1 + 0$

$= -1$ 

(ii) $(+4) + (-2) = (+2) + [(+2) + (-2)]$

$= (+2) + 0$

$= +2$ 

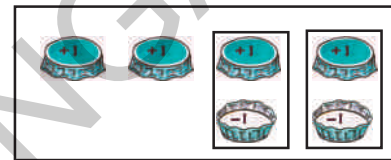
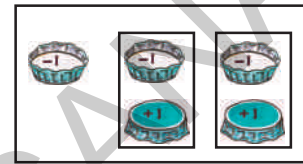

Now you can play the game by adding scores easily.

Do This

Find the values of the following:

(i) $-7 + 8$

(ii) $-3 + 5$

(iii) $-3 - 2$

(iv) $+7 - 10$

6.6.1 Addition of integers on the number line

Let us see how we can add any two integers using a number line.

1. Let us add 2 and 3 on a number line.

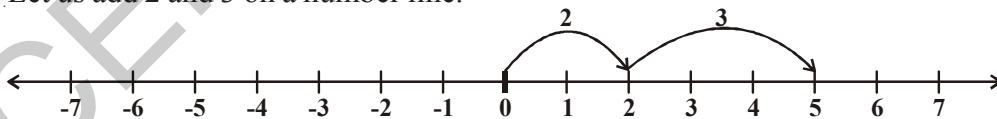

On the number line, we first move 2 steps to the right from 0 to reach 2, then we move 3 steps to the right of 2 and to reach 5. Thus we get $2 + 3 = 5$.

2. Let us add (-4) and (-3) .

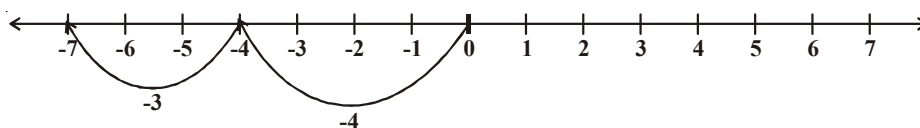

On the number line, we first move 4 steps to the left of 0 to reach -4, then we move 3 steps to the left of -4 and reach -7. Thus, $(-4) + (-3) = -7$.

3. Suppose we wish to find the sum of $(+6)$ and (-2) on the number line. First we move to the right of 0 by 6 steps to reach 6. Then we move 2 steps to the left of 6 to reach 4.

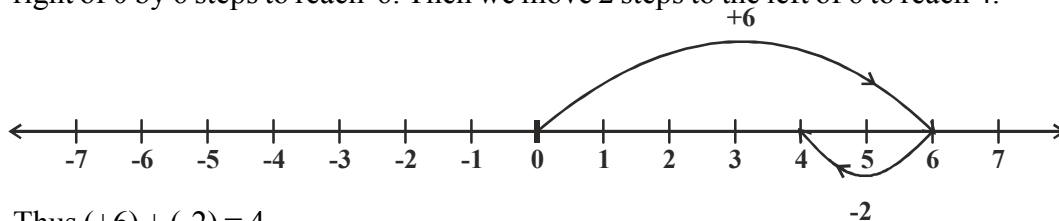

4. Similarly let us find the sum of (-5) and $(+3)$ on the number line. First we move 5 steps to the left of 0 reach -5 and then from this point we move 3 steps to the right. We reach the point -2 . Thus, $(-5) + (+3) = -2$

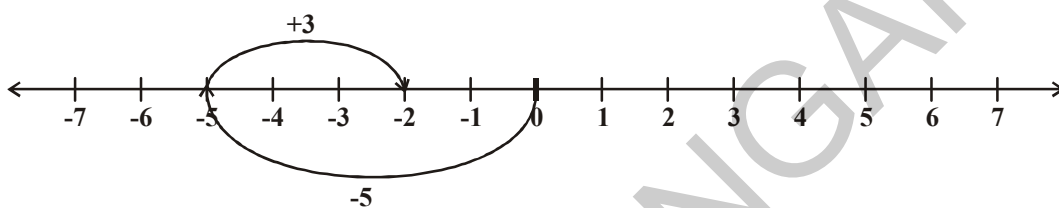

5. Suneetha adds 3 and -3 . She first moves from 0 to $+3$ and then from $+3$ she move 3 points to the left. Where does she reach ultimately?

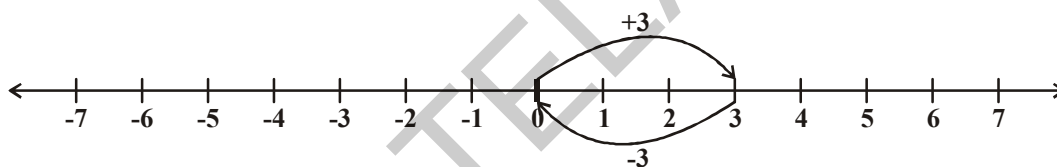

From the number line $3 + (-3) = 0$

Similarly, if we add 1 and -1 , 2 and -2 , 3 and -3 so on we obtain the sum as zero. They are called additive inverse of each other i.e. **any two distinct numbers that give zero when added to each other are additive inverse of each other.**

What is additive inverse of 7?

What is additive inverse of -8 ?



TRY THESE

- Find the value of the following using a number line.
 - $(-3) + 5$
 - $(-5) + 3$

Make your own two new questions and solve them using the number line.
- Find the solution of the following without using number line.
 - $(+5) + (-5)$
 - $(+6) + (-7)$
 - $(-8) + (+2)$

Ask your friend to give five such questions and solve them.

Observe the following:

$$\begin{array}{lll} \text{(i)} & 3 + 2 = 5 & 20 + 6 = 26 & 30 + 22 = 52 \\ & 8 + 16 = 24 & 9 + 10 = 19 & 20 + 14 = 34 \end{array}$$

We can see that the sum of two positive integers is also a positive number.

Look at the following now:

$$\text{(ii)} \quad -4 + (-6) = -10 \qquad -8 + (-12) = -20 \qquad -3 + (-9) = -12$$

What do you learn from this? The sum of two negative integers is always a negative integer. What happens if one integer is positive and the other negative? Let us see these:

$$\text{(iii)} \quad \begin{array}{ll} 15 + (-17) = -2 & -23 + 4 = -19 \\ -11 + 16 = 5 & -12 + 12 = 0 \end{array}$$

From the above, we can conclude that when we add two integers one of which is positive and the other negative, then the sum may be either positive, negative or zero.

Example-1. Find the sum of $(-10) + (+14) + (-5) + (+8)$

Solution: We can rearrange the numbers so that the positive integers and the negative integers groups together. We have

$$\begin{aligned} & (-10) + (+14) + (-5) + (+8) \\ & = (-10) + (-5) + (+14) + (+8) \\ & = -15 + 22 = 7. \end{aligned}$$

Example-2. Find the sum of (-20) , (-82) , (-28) and (-14) .

Solution:

$$\begin{aligned} & (-20) + (-82) + (-28) + (-14) \\ & = -144 \end{aligned}$$

Example-3. Find the sum of $25 + (-21) + (-20) + (+17) + (-1)$

Solution:

$$\begin{aligned} & 25 + (-21) + (-20) + (+17) + (-1) = 25 + (+17) + (-21) + (-20) + (-1) \\ & = 42 - 42 = 0 \end{aligned}$$

EXERCISE - 6.3

1. Add the following integers using number line.

$$\begin{array}{lll} \text{(i)} & 7 + (-6) & \text{(ii)} & (-8) + (-2) & \text{(iii)} & (-6) + (-5) + (+2) \\ \text{(iv)} & (-8) + (-9) + (+17) & \text{(v)} & (-3) + (-8) + (-5) & \text{(vi)} & (-1) + 7 + (-3) \end{array}$$

2. Add without using number line.

$$\begin{array}{lll} \text{(i)} & 10 + (-3) & \text{(ii)} & -10 + (+16) & \text{(iii)} & (-8) + (+8) \\ \text{(iv)} & -215 + (+100) & \text{(v)} & (-110) + (-22) & \text{(vi)} & 17 + (-11) \end{array}$$

3. Find the sum of:

$$\begin{array}{ll} \text{(i)} & 120 \text{ and } -274 & \text{(ii)} & -68 \text{ and } 28 \\ \text{(iii)} & -29, 38 \text{ and } 190 & \text{(iv)} & -60, -100 \text{ and } 300. \end{array}$$

4. Simplify:

(i) $(-6) + (-10) + 5 + 17$

(ii) $30 + (-30) + (-60) + (-18)$

(iii) $(-80) + (+40) + (-30) + (+6)$

(iv) $70 + (-18) + (-10) + (-17)$

6.6.2 Subtraction of integers

We saw that to add 5 and (-2) on a number line we can start from 5 and then move 2 steps to the left of 5.

We reach at 3 so, we have $5 + (-2) = 3$

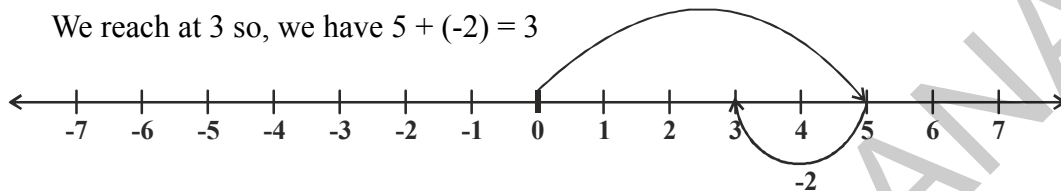

Thus, we find that to add a positive integer we move towards the right on a number line and for adding a negative integer we move towards left.

We have also seen that while subtracting whole numbers on a number line, we would move towards left.

For example take $5 - 2 = ?$

We start from 5 and take two steps to the left and end up at 3.

What does subtraction of a negative integer mean?

Let us observe the following example,

Example-4. Subtract -5 from 6.

Solution: To subtract -5 from 6, let us start at 6 and move 5 towards the right. For -5 we would have moved left but for $-(-5)$ we would move in the opposite direction. Moving 5 to the right, we reach 11.

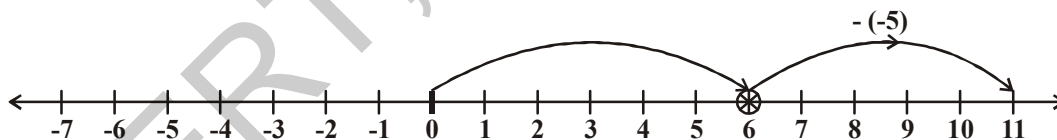

We have $6 - (-5) = 11$

i.e. To subtract -5 from 6 means add 5 (the additive inverse of -5) to 6.

$$6 - (-5) = 6 + 5 = 11$$

What would we do for $4 - (-2)$? Would you move towards the left on the number line or towards the right? If we move to the left then we reach 2. Then we have to say $4 - (-2) = 2$. This is not true because we know $4 - 2 = 2$ and $4 - (-2) \neq 4 - 2$.

So for $4 - (-2)$ we move two steps to the right of 4. This is opposite of what we would do for $4 - (2)$. We reach 6 in one case and reach 2 in the other.

Example-5. Find the value of $(-7) - (-9)$ using number line.

Solution:

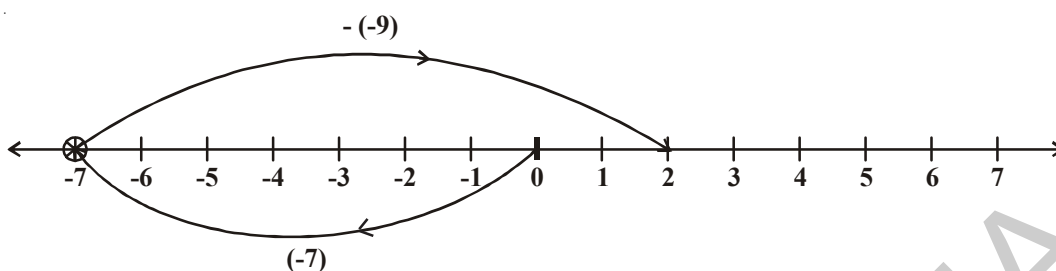

$(-7) - (-9)$ is equal to $-7 + 9$ (Since -9 is additive inverse of 9).

On the number line, start from -7 and move 9 units to right, we will reach 2 .

So $(-7) - (-9) = -7 + 9 = 2$.



Do This

- | | | |
|----------------|-----------------|------------------|
| i) $-5 - (-3)$ | ii) $-7 - (+2)$ | iii) $-7 - (-5)$ |
| iv) $3 - (-4)$ | v) $5 - (+7)$ | vi) $4 - (-2)$ |

THINK, DISCUSS AND WRITE

$$3 - 3 = 0$$

$$3 - 2 = 1$$

$$3 - 1 = 2$$

$$3 - 0 = 3$$

$$3 - (-1) = 4$$

$$3 - (-2) = 5$$

$$3 - (-3) = 6$$

Observe that as the number we subtract from 3 is decreasing, the result obtained is increasing.

Is it true for all Integers?



Example-6. Subtract (-6) from (-13) .

Solution: $(-13) - (-6) = (-13) + (\text{additive inverse of } -6)$
 $= -13 + 6 = -7$.

Example-7. Subtract $(+8)$ from (-8)

Solution: $(-8) - (+8) = (-8) + (\text{additive inverse of } +8)$
 $= -8 + (-8) = -16$

Example-8. Simplify: $(-6) - (+7) - (-24)$

Solution: $(-6) - (+7) - (-24) = (-6) + (\text{additive inverse of } +7) + (\text{additive inverse of } -24)$



EXERCISE - 6.4

- Find:
 - $40 - (22)$
 - $84 - (98)$
 - $(-16) + (-17)$
 - $(-20) - (13)$
 - $(38) - (-6)$
 - $(-17) - (-36)$
- Fill in the blanks with appropriate $>$, $<$ or $=$ sign:
 - $(-4) + (-5)$ _____ $(-5) - (-4)$
 - $(-16) - (-23)$ _____ $(-6) + (-12)$
 - $44 - (-10)$ _____ $47 + (-3)$
 - $(-21) + (-22)$ _____ $(-22) + (-21)$
- Fill in the blanks:
 - $(-13) +$ _____ $= 0$
 - $(-16) + 16 =$ _____
 - $(-5) +$ _____ $= -14$
 - _____ $- 16 = -22$
- Simplify:
 - $(-6) - (5) - (+2)$
 - $(-12) + 42 - 7 - 2$
 - $(-3) + (-6) + (-24)$
 - $40 - (-50) - (2)$



WHAT HAVE WE DISCUSSED?

- We use negative numbers to represent debit, temperatures below the 0°C , past periods of time, depth below sea level.
- The collection of all the positive numbers $\{1, 2, 3, \dots\}$, negative numbers $\{-1, -2, -3, \dots\}$ and zero put together, they are called integers. Set of integers is denoted by the letter 'I' or Z. And $Z = \{\dots -3, -2, -1, 0, 1, 2, 3, \dots\}$.
- We can show the addition and subtraction of integers on the number line.
- When two positive integers are added, we get a positive integer.
- When two negative integers are added, we get a negative integer.
- The subtraction of integers is the same as the addition of their additive inverse.



Fun with Integers !

In its search for water a frog fell down into a 30m deep well. Its progress out of the well was very erratic. Each day it managed to climb up 3m, but the following night, it slipped back 2 m. How many days did it take to get out of the well?

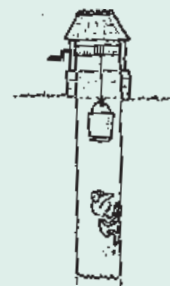



7.1 INTRODUCTION

Ramu bought an apple and wanted to share it equally with his friend. This means that the apple has to be divided into two equal pieces. Ramu will take one piece and his friend the other.

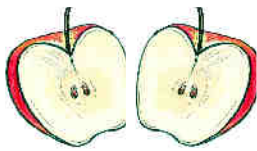

the other half.

Reshma asked that if there were four friends then what will Ramu do? Ramu further divided his half apple into two equal parts and asked Reshma what fraction of the whole apple was that piece. He also did the same with



Reshma said that these four equal parts together make one whole. So each equal part is one-fourth of one whole apple.

Therefore we can say that when something is divided into two equal parts each part represents one half of the whole. (See the figure given below)

One Whole part



Cut along the dotted line



7.2 A FRACTION

A fraction means a part of a group or of a whole.

$\frac{5}{12}$ is a fraction. We read it as 'five-twelfths'.

What does '12' stand for? It is the number of equal parts into which the whole has been divided. What does '5' stand for? It is the number of equal parts which have been taken out or selected.

Here 5 is called the numerator and 12 is called the denominator.

What is the numerator of $\frac{3}{7}$ and the denominator of $\frac{4}{15}$.



TRY THESE

1. Represent the following pictorially:

i. $\frac{3}{4}$

ii. $\frac{2}{8}$

iii. $\frac{1}{3}$

iv. $\frac{5}{8}$

2. Write the fraction representing the shaded portion.

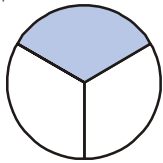

(i)

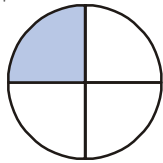

(ii)



(iii)

These fractions are less than one and are parts of a whole. These are called **proper fractions**. In proper fractions, always numerator is less than denominator.



DO THIS

1. Write 5 proper fractions and draw them pictorially.

2. Rani says that shaded portion in given figure represents $\frac{1}{4}$.
Do you agree with her? Give reason to support your answer.

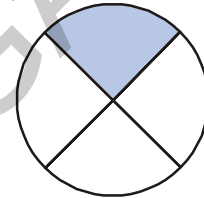

7.2.1 Improper Fractions

Consider fractional numbers that are more than one. They are called improper fractions.

For example $\frac{3}{2}, \frac{5}{2}, \frac{7}{3}, \frac{8}{2}$ etc. Check whether the denominator is greater than numerator?

Write 5 more improper fractional numbers.

How do we represent these improper fractions pictorially? Let us consider an example.

Each circle represents a whole. We have 2 wholes out of which three equal parts are shaded. There are 3 parts and each whole is divided in to two parts. Therefore this is a representation of $\frac{3}{2}$. We notice that for representing an improper fraction we need to have more than one whole.

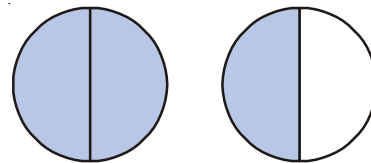

DO THIS

1. Write improper fractions represented by the following pictures.

(i)

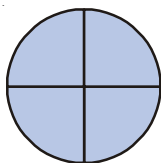



2. Represent the following fractions pictorially:

$$\frac{7}{4}, \quad \frac{5}{3}, \quad \frac{7}{6}$$

7.2.2 Mixed Fractions

Value of improper fractions are greater than one. For example $\frac{5}{2}$ has 5 halves.

$$\frac{5}{2} = \frac{1}{2} + \frac{1}{2} + \frac{1}{2} + \frac{1}{2} + \frac{1}{2} = 5 \times \frac{1}{2}$$

We represent this as:

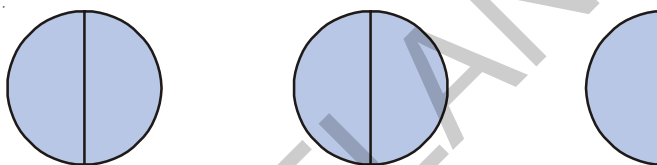

This has 2 complete wholes and a half, i.e., $2 + \frac{1}{2}$ and we write it as $2\frac{1}{2}$. Here, we say that $2\frac{1}{2}$ is in the form of a mixed fraction.

Similarly $\frac{5}{3}$ has one complete wholes and two thirds besides. $\frac{5}{3} = \frac{1}{3} + \frac{1}{3} + \frac{1}{3} + \frac{1}{3} + \frac{1}{3} = 5 \times \frac{1}{3}$

It can be represented as $1\frac{2}{3}$.

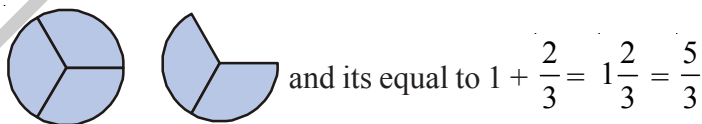

Each improper fraction can be represented as mixed fraction.

Do This

Write the following as mixed fractions.

$$\frac{7}{2}, \quad \frac{8}{5}, \quad \frac{9}{4}, \quad \frac{13}{5}, \quad \frac{17}{3}$$

7.3 NUMERATOR AND DENOMINATOR

We can see from above that any two whole numbers written in the form $\frac{1}{2}, \frac{1}{3}, \frac{5}{4}, \frac{3}{4}, \frac{2}{3}$ represent fractional numbers. In this the only condition is that the denominator can not be equal to 0. Why?



TRY THESE

1. Write the numerator and denominators of the following fractional numbers:

$$\frac{1}{3}, \frac{2}{5}, \frac{7}{2}, \frac{19}{3}, \frac{7}{29}, \frac{11}{13}, \frac{1}{7}, \frac{8}{3}$$

2. Sort the following fractions into the category of proper and improper fractions. Also write improper fractions as mixed fractions:

$$\frac{1}{3}, \frac{2}{7}, \frac{8}{3}, \frac{3}{5}, \frac{5}{3}, \frac{1}{9}, \frac{9}{5}, \frac{8}{7}$$

7.4 FRACTIONAL NUMBERS ON THE NUMBER LINE

We can show fractional numbers on the number line also.

Let us draw a number line and mark $\frac{1}{2}$ on it.

We know that $\frac{1}{2}$ is greater than 0 and less than 1, so it should lie between 0 and 1.



[Divided the gap between 0 and 1 into 2 equal parts and show one part as $\frac{1}{2}$]

Similarly $\frac{1}{3}$ and $\frac{2}{3}$ can be shown as below:

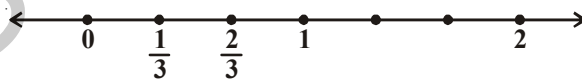

[One unit has to divide into 3 equal parts]

$\frac{1}{5}, \frac{2}{5}, \frac{3}{5}, \frac{4}{5}$ can be shown as follows:

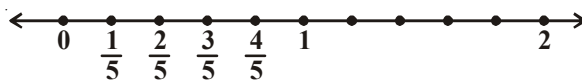

[The gap between line

How do we show $\frac{4}{3}$ on the number line? $\frac{4}{3}$ has four one thirds. It is more than one. To represent $\frac{4}{3}$ we need one more one third after 1.

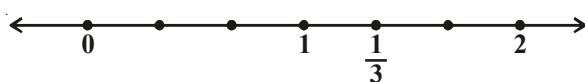

$$\frac{4}{3} = \frac{3}{3} + \frac{1}{3} = 1 + \frac{1}{3}$$

After 1 unit divide the gap between 1 and 2 into 3 equal parts.

If we consider $\frac{9}{4}$ then this number has 9 one fourths. This number would therefore be marked as shown

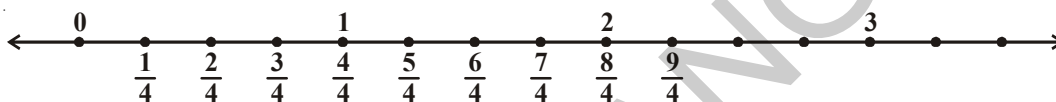

This number is thus after 2 on the number line and is written as $2\frac{1}{4}$.



DO THIS

- Show the following on number lines:
 - $\frac{7}{6}$
 - $\frac{5}{2}$
 - $\frac{7}{5}$
 - $\frac{9}{6}$
- Consider the following numbers. Which of these would lie on the number line:
 - before 1
 - between 1 and 2 $\frac{17}{8}, \frac{11}{4}, \frac{1}{3}, \frac{7}{9}, \frac{7}{5}, \frac{6}{11}, \frac{9}{2}, \frac{9}{5}$



EXERCISE - 7.1

- Out of these which are proper fractional numbers?
 - $\frac{3}{2}$
 - $\frac{2}{5}$
 - $\frac{1}{7}$
 - $\frac{8}{3}$
- Which of these are improper fractional numbers?
 - $\frac{2}{7}$
 - $\frac{7}{11}$
 - $\frac{9}{11}$
 - $\frac{13}{2}$
 - $\frac{7}{3}$

Write where each of the above improper fractional numbers would lie on the number line?

3. Pick out the mixed fractions from these:

- (i) $\frac{3}{5}$ (ii) $1\frac{2}{7}$ (iii) $\frac{7}{2}$ (iv) $2\frac{3}{5}$

4. Convert the following improper fractions into mixed fractions:

- (i) $\frac{7}{3}$ (ii) $\frac{11}{2}$ (iii) $\frac{9}{4}$ (iv) $\frac{27}{4}$

5. Convert the following mixed fractions into improper fractions.

- (i) $1\frac{2}{7}$ (ii) $3\frac{2}{8}$ (iii) $10\frac{2}{9}$ (iv) $8\frac{7}{9}$

7.5 EQUIVALENT FRACTIONS

Consider the following four fractions and their representations. The size of the shaded part is the same in all four figures and the whole is also the same.

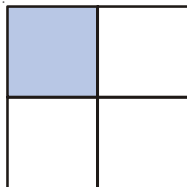

$$\frac{1}{4}$$

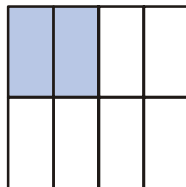

$$\frac{2}{8}$$

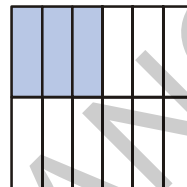

$$\frac{3}{12}$$

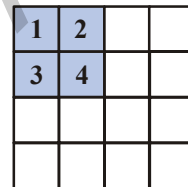

$$\frac{4}{16}$$

If we look at these closely we find that the numerator and denominator of $\frac{2}{8}$ are twice the numerator and denominator of $\frac{1}{4}$. Similarly $\frac{3}{12}$ has the numerator and denominator multiplied by 3 each.

$$\text{We see } \frac{1}{4} = \frac{2}{8} = \frac{3}{12} = \frac{4}{16}$$

All these fractions are equivalent to $\frac{1}{4}$.

We can say that the equivalent fractions arise when we multiply both the numerator and the denominator by the same number.

The equivalent fractions of $\frac{1}{3}$ are $\frac{2}{6}, \frac{3}{9}, \frac{4}{12}, \frac{5}{15}$ etc.

7.6 STANDARD FORM OF A FRACTION

Out of the equivalent fractions $\frac{1}{3}, \frac{2}{6}, \frac{3}{9}, \frac{4}{12}, \dots$ etc. $\frac{1}{3}$ is the standard form. It is the standard form as the numerator and denominator are in lowest terms and do not have any common factors other than 1.

For example $\frac{2}{3}, \frac{7}{3}, \frac{17}{7}, \frac{1}{5}, \frac{3}{11}$ are all standard forms.



TRY THESE

- Write 5 fractional numbers that are in the standard form.
- Write 5 fractional numbers that are not in standard form.
- Convert the following fractions into their standard form.

(i) $\frac{7}{28}$

(ii) $\frac{15}{90}$

(iii) $\frac{11}{33}$

(iv) $\frac{39}{13}$

7.7 LIKE AND UNLIKE FRACTIONS

In a mathematics exam, Ramu got 5 marks out of 25. We write it as $\frac{5}{25}$. Raju got $\frac{10}{25}$ and Ravi got $\frac{21}{25}$.

It is clear that Ravi got the highest marks of three. It is easy to see that the numerator of that fractions is the highest and the all have the same denominator.

The fractional numbers that have the same denominators are called **like fractions**. As we see, these can be compared easily. Fractions where the denominators are not the same are **unlike fractions**.

Example $\frac{1}{3}$ and $\frac{1}{7}$ are unlike fractions. $\frac{2}{4}$ and $\frac{6}{12}$ are also unlike fractions.

While, $\frac{2}{4}$ and $\frac{6}{12}$ are equivalent fractions but they are unlike fractions.



EXERCISE - 7.2

- Which group of fractions are like fractions among the following?
 - $\frac{2}{7}, \frac{3}{7}, \frac{4}{7}$
 - $\frac{1}{9}, \frac{2}{9}, \frac{4}{9}$
 - $\frac{3}{7}, \frac{4}{9}, \frac{7}{11}$
- Write five groups of like fractions.
- From each of these identify like fractional numbers:
 - $\frac{2}{3}, \frac{5}{3}, \frac{1}{3}, \frac{4}{6}$
 - $\frac{1}{7}, \frac{3}{5}, \frac{2}{5}, \frac{1}{9}$
 - $\frac{7}{8}, \frac{8}{7}, \frac{2}{8}, \frac{7}{5}$

THINK, DISCUSS AND WRITE

Rafi says "There can be no equivalent fractions that are also like fractions."
Do you agree with him? Explain your answer and justify.



7.8 ASCENDING AND DESCENDING ORDER OF FRACTIONS

Whenever we have a set of numbers, we compare them. Some are bigger than the others, some are smaller. We can see that 7 is smaller than 19 and bigger than 3. We also know that 3 is bigger than -5. Can we make such comparisons in fractional numbers so easily. Let us consider these through a few examples.

In a school test Suresh got $\frac{7}{10}$, Seetha got $\frac{9}{10}$, Rakesh got $\frac{5}{10}$. We know that Seetha got the most marks and that $\frac{9}{10}$ is bigger than $\frac{7}{10}$. $\frac{9}{10}$ represents 9 parts taken out of 10 equal parts. That is more than 7 parts out of 10 equal parts. It is easy to see this as the denominators are equal. For example out of $\frac{3}{2}$ and $\frac{1}{2}$, it is $\frac{3}{2}$ that is bigger. If we want to show the fractions $\frac{7}{10}, \frac{9}{10}, \frac{5}{10}$ in ascending order we show them as $\frac{5}{10}, \frac{7}{10}, \frac{9}{10}$. Can you show them in descending order?



DO THIS

Identify the biggest and the smallest in these group of fractional numbers

(i) $\frac{1}{7}, \frac{3}{7}, \frac{2}{7}, \frac{5}{7}$ (ii) $\frac{1}{9}, \frac{13}{9}, \frac{11}{9}, \frac{5}{9}$

(iii) $\frac{1}{3}, \frac{5}{3}, \frac{17}{3}, \frac{9}{3}$

7.8.1 Comparing Unlike Fractions

Let us now compare $\frac{2}{3}$ and $\frac{3}{5}$? Which of these is bigger?

We cannot now tell just by looking at the numbers. In the first, 2 parts out of three and in the second 3 parts out of five are taken. Can we say that the one with 3 parts is bigger? We cannot directly compare the fractional numbers just by looking at numerators. To compare such unlike

fractions we have to convert them to like fractions. So we convert both $\frac{2}{3}$ and $\frac{3}{5}$ in the following way.

$$\frac{2}{3} = \frac{2}{3} \times \frac{5}{5} = \frac{10}{15}$$

$$\frac{3}{5} = \frac{3}{5} \times \frac{3}{3} = \frac{9}{15}$$

Therefore, $\frac{9}{15} < \frac{10}{15}$ and thus $\frac{3}{5} < \frac{2}{3}$

Consider another example. Which is bigger out of $\frac{7}{9}$, $\frac{3}{11}$?

Converting them into like fractions.

$$\frac{7}{9} \times \frac{11}{11} = \frac{77}{99} \quad ; \quad \frac{3}{11} \times \frac{9}{9} = \frac{27}{99}$$

$\frac{77}{99}$ is a big one. So, $\frac{7}{9}$ is a big one. $\frac{7}{9} > \frac{3}{11}$.

In all these we have tried to make the denominators of both the fractions same. Once the denominators are the same the size of the parts is the same. We can then compare the number of parts and see which fractional number has more equal parts to find the bigger fraction.

Do THIS

Which of these is the smaller fraction?

- (i) $\frac{2}{5}$, $\frac{3}{7}$ (ii) $\frac{7}{8}$, $\frac{5}{4}$ (iii) $\frac{3}{11}$, $\frac{1}{2}$ (iv) $\frac{5}{6}$, $\frac{2}{3}$

7.8.2 Ascending and Descending Order

We know that when we write numbers in a form that increase from the left to the right then they are in the ascending order.

For example 1, 3, 7, 8, 12 are in ascending order:

Similarly,

$\frac{2}{5}$, $\frac{3}{5}$, $\frac{7}{5}$, $\frac{16}{5}$ are also in ascending order. Here $\frac{2}{5} < \frac{3}{5} < \frac{7}{5} < \frac{16}{5}$

And $\frac{1}{7}$, $\frac{1}{6}$, $\frac{1}{5}$, $\frac{1}{4}$ are also in ascending order.

Do THIS

Write the following fractional number in ascending order:

- (i) $\frac{1}{7}$, $\frac{13}{7}$, $\frac{11}{7}$, $\frac{5}{7}$, $\frac{15}{7}$ (ii) $\frac{2}{3}$, $\frac{5}{6}$, $\frac{3}{9}$, $\frac{24}{18}$
 (iii) $\frac{2}{3}$, $\frac{1}{2}$, $\frac{5}{6}$, $\frac{7}{12}$ (iv) $\frac{1}{5}$, $\frac{1}{2}$, $\frac{1}{8}$, $\frac{1}{3}$, $\frac{1}{12}$

When we write numbers in the manner that they decrease from left to right then they are said to be in descending order.

For example 100, 85, 83, 74, 61 are in descending order.

Similarly $\frac{11}{2}, \frac{7}{2}, \frac{5}{2}, \frac{3}{2}, \frac{1}{2}$ are in descending order.

Further $\frac{1}{4}, \frac{1}{5}, \frac{1}{6}, \frac{1}{7}$ are also in descending order. Can you say why? Discuss with your friends.

Do This

Write the following in descending order:

- (i) $\frac{1}{9}, \frac{13}{9}, \frac{11}{9}, \frac{15}{9}, \frac{3}{9}$ (ii) $\frac{1}{6}, \frac{2}{3}, \frac{3}{9}, \frac{5}{6}$
 (iii) $\frac{1}{5}, \frac{9}{5}, \frac{3}{5}, \frac{6}{5}$ (iv) $\frac{1}{4}, \frac{1}{2}, \frac{1}{8}, \frac{3}{4}$

7.9 ADDITION OF FRACTIONS

Add the following

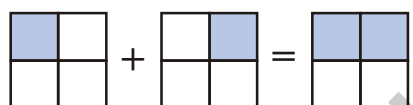
1.  $= \frac{1}{4} + \frac{1}{4} = \frac{1}{2}$

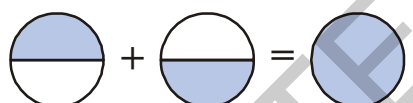
2.  $= \frac{1}{2} + \frac{1}{2} = \frac{2}{2} = 1$

Do This

Simplify the following

- i. $\frac{1}{4} + \frac{5}{4}$ ii. $\frac{1}{3} + \frac{2}{3}$ iii. $\frac{1}{7} + \frac{2}{7} + \frac{3}{7}$ iv. $\frac{13}{6} + \frac{5}{6}$

7.9.1 Adding unlike fractions

Look at the following

$$\frac{1}{2} + \frac{1}{3} = ?$$

We can not add the numerators here. Why? So what do we do?

To add such fractions we convert them into equivalent fractions with the same denominators.

$$\frac{1}{2} = \frac{1}{2} \times \frac{3}{3} = \frac{3}{6} \quad ; \quad \frac{1}{3} = \frac{1}{3} \times \frac{2}{2} = \frac{2}{6}$$

So, $\frac{1}{2} + \frac{1}{3} = \frac{3}{6} + \frac{2}{6} = \frac{5}{6}$

Let us see how this works pictorially.

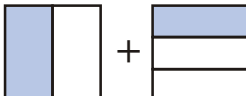
$$\frac{1}{2} + \frac{1}{3}$$



The parts in the two pictures are not equal. In order to add we need equal parts.

We divide the first into three more horizontal parts.

We get $\frac{3}{6}$



and for the second picture similarly we get $\frac{2}{6}$.



Now we can add both and get sum as $\frac{5}{6}$



Consider $\frac{1}{6} + \frac{5}{3}$

We write $\frac{5}{3} = \frac{10}{6}$

Thus $\frac{1}{6} + \frac{5}{3} = \frac{1}{6} + \frac{10}{6} = \frac{11}{6}$



DO THIS

Add the following fractional numbers:

(i) $\frac{1}{2} + \frac{1}{5}$

(ii) $\frac{1}{2} + \frac{3}{2} + \frac{7}{2}$

(iii) $\frac{1}{3} + \frac{2}{6} + \frac{5}{6}$

(iv) $\frac{1}{3} + \frac{7}{5}$

7.9.2 Addition of mixed fractions

How do we add $2\frac{1}{3}$ and $1\frac{2}{3}$?

One way is to convert them into improper fractions $\frac{7}{3}$ and $\frac{5}{3}$ and add. We can also add them in the following way

$$2\frac{1}{3} + 1\frac{2}{3} = 2 + 1 + \frac{1}{3} + \frac{2}{3}$$

We have added the whole number part and the fractional part separately. Then we add the two and get $3 + \frac{3}{3} = 3 + 1 = 4$.

We will now add $2\frac{1}{8}$, $3\frac{1}{6}$ in both ways.

$$\begin{aligned} \text{1st Method : } 2\frac{1}{8} + 3\frac{1}{6} &= 2 + 3 + \frac{1}{8} + \frac{1}{6} \\ &= 5 + \frac{1 \times 6}{8 \times 6} + \frac{1 \times 8}{6 \times 8} \\ &= 5 + \frac{6}{48} + \frac{8}{48} \\ &= 5 + \frac{14}{48} = 5 + \frac{7}{24} = 5\frac{7}{24} \end{aligned}$$

2nd Method : Changing both into improper fractions we have $\frac{17}{8} + \frac{19}{6}$

$$\text{Change into equivalent like fractions } \frac{17}{8} = \frac{17}{8} \times \frac{6}{6} = \frac{102}{48}$$

$$\frac{19}{6} = \frac{19}{6} \times \frac{8}{8} = \frac{152}{48}$$

$$\therefore \frac{102}{48} + \frac{152}{48} = \frac{254}{48} = \frac{127}{24} = 5\frac{7}{24}$$

7.10 SUBTRACTION

Subtract $\frac{3}{7}$ from $\frac{4}{7}$. Here the numbers have the same denominator so they are like fractions. We take 3 one sevenths from 4 one sevenths and are left with 1 one seventh.

$$\therefore \frac{4}{7} - \frac{3}{7} = \frac{4-3}{7} = \frac{1}{7}$$

Now take an example where fractional numbers have different denominators.

Subtract $\frac{2}{9}$ from $\frac{3}{10}$

$$\frac{3}{10} - \frac{2}{9}$$

We can not do the same process as we did above.

We make them equivalent like fractions and write

$$\frac{3}{10} = \frac{3 \times 9}{10 \times 9} = \frac{27}{90}; \quad \frac{2}{9} = \frac{2 \times 10}{9 \times 10} = \frac{20}{90}$$

$$\text{We get } \frac{27}{90} - \frac{20}{90} = \frac{27-20}{90} = \frac{7}{90}$$



Do This

1. Add the following fractions.

(i) $\frac{2}{5} + \frac{3}{5}$ (ii) $\frac{7}{10} + \frac{2}{10}$ (iii) $\frac{3}{4} + \frac{2}{6}$

2. Subtract the following.

(i) $\frac{2}{7}$ from $\frac{3}{5}$ (ii) $\frac{1}{9}$ from $\frac{2}{5}$



EXERCISE - 7.3

1. Write shaded portion as fraction. Arrange them in ascending or descending order using sign '<', '=', '>' between the fractions:

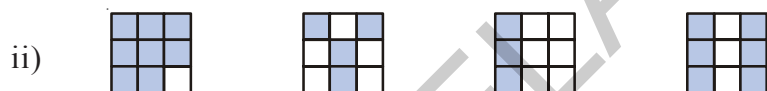
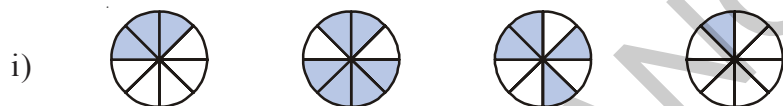

2. Show $\frac{2}{6}$, $\frac{4}{6}$, $\frac{8}{6}$, $\frac{5}{6}$ and $\frac{6}{6}$ on the number line. Also arrange them in ascending order.

3. Look at the figures and write '<' or '>', '=' between the given pairs of fractions:

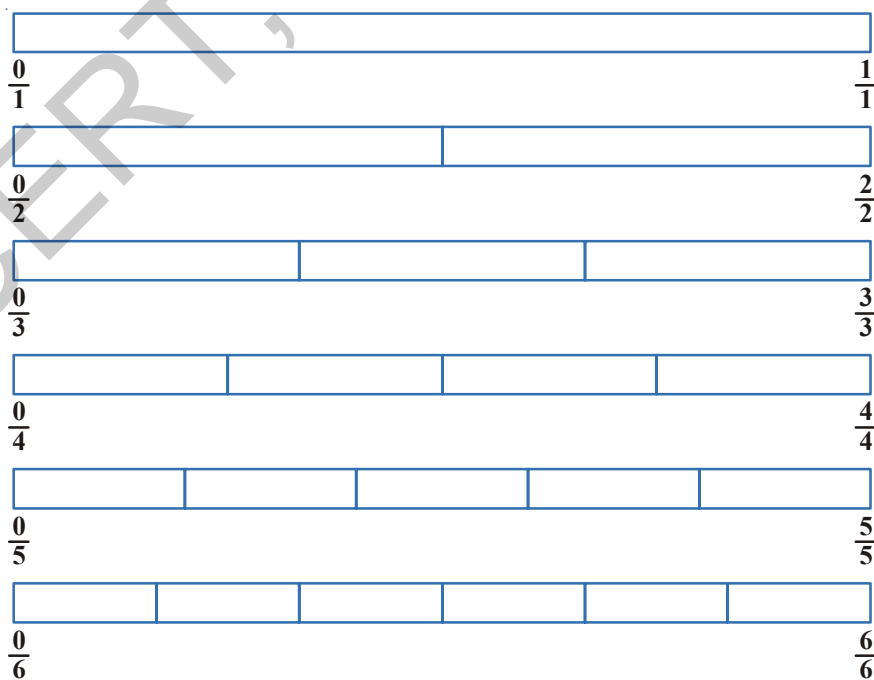

(i) $\frac{1}{6} \square \frac{1}{3}$ (ii) $\frac{3}{4} \square \frac{2}{6}$ (iii) $\frac{2}{3} \square \frac{2}{4}$

(iv) $\frac{6}{6} \square \frac{3}{3}$ (v) $\frac{5}{6} \square \frac{5}{5}$

Make five more such problems and ask your friends to solve them.

4. Fill with the appropriate sign. ('<', '=', '>')

(i) $\frac{1}{2} \square \frac{1}{5}$ (ii) $\frac{2}{4} \square \frac{3}{6}$ (iii) $\frac{3}{5} \square \frac{2}{3}$

(iv) $\frac{3}{4} \square \frac{2}{8}$ (v) $\frac{3}{5} \square \frac{6}{5}$ (vi) $\frac{7}{9} \square \frac{3}{9}$

5. Answer the following. Also write how you solved them.:

(i) Is $\frac{5}{9}$ equal to $\frac{4}{5}$? (ii) Is $\frac{9}{16}$ equal to $\frac{5}{9}$?

(iii) Is $\frac{4}{5}$ equal to $\frac{16}{20}$? (iv) Is $\frac{1}{15}$ equal to $\frac{4}{30}$?

6. Varshith read 25 pages of a story book containing 100 pages. Lalitha read $\frac{2}{5}$ of the same story book. Who read less? Give reason.

7. Fill the appropriate (+ or -) sign in the blank space.

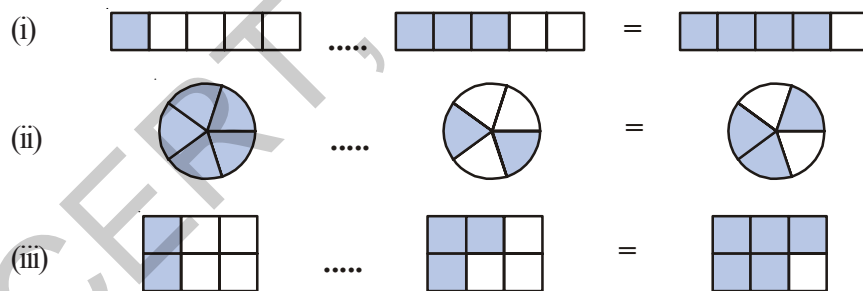

8. Simplify

(i) $\frac{1}{18} + \frac{1}{18}$ (ii) $\frac{8}{15} + \frac{3}{15}$ (iii) $\frac{7}{7} - \frac{5}{7}$

(iv) $\frac{1}{22} + \frac{21}{22}$ (v) $\frac{12}{15} - \frac{7}{15}$ (vi) $\frac{5}{8} + \frac{3}{8}$

vii) $1 - \frac{2}{3} \left(1 = \frac{3}{3} \right)$ viii) $\frac{1}{4} + \frac{0}{4}$ ix) $3 - \frac{12}{5}$

9. Fill the missing fractions in the boxes.

(i) $\frac{7}{10} - \square = \frac{3}{10}$

(ii) $\square - \frac{3}{21} = \frac{5}{21}$

(iii) $\square - \frac{3}{3} = \frac{3}{6}$

(iv) $\square + \frac{5}{27} = \frac{12}{27}$

10. Narendra painted $\frac{2}{3}$ area of the wall in his room. His brother Ritesh helped and painted $\frac{1}{3}$ area of the wall. How much did they paint together?

11. Neha was given $\frac{5}{7}$ of a basket of bananas. What fraction of bananas was left in the basket?

12. A piece of rod $\frac{7}{8}$ metre long is broken into two pieces. One piece was $\frac{1}{4}$ metre long. How long is the other piece?

13. Renu takes $2\frac{1}{5}$ minutes to walk around the school ground. Snigdha takes $\frac{7}{4}$ minutes to do the same. Who takes less time and by what fraction?

7.11 DECIMALS

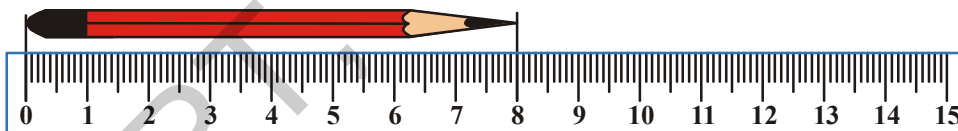

What is the length of this pencil? centimeter.

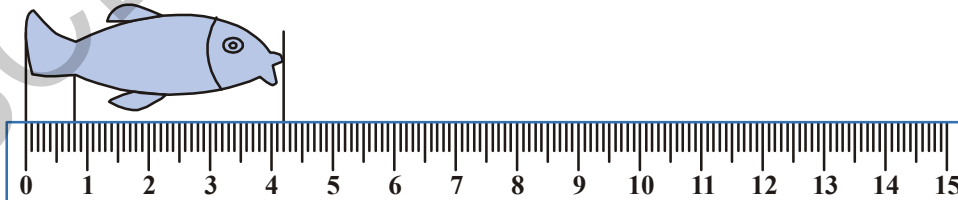

The length of this fish is more than 4 cm. But it is less than 5 cm. How will you find the length of this fish?

To do this we divide the space between 4 and 5 into 10 equal parts.

Now can you measure the length of this fish? The length is cm and small part. We call this small part as millimeter. That means this fish is 4 cm and 2 mm in length. Each of the 10 equal parts is one milli meter. In using the scale we use equal divisions and count the smaller parts.

In the above examples, the length of the fish is

$$4 \text{ and } \frac{2}{10} \text{ part} = 4 \frac{2}{10} \text{ cm}$$

What is the length of the tail of the fish?

You find it is less than 1 cm and is equal to 8 parts out of the 10 equal parts.

$$\text{Thus it is } \frac{1}{10} + \frac{1}{10} + \frac{1}{10} + \frac{1}{10} + \frac{1}{10} + \frac{1}{10} + \frac{1}{10} + \frac{1}{10} = \frac{8}{10} \text{ cm}$$



Look at the match stick. Measure the length of the match stick and write it in centimeters and in millimeters.

$$1 \text{ part of each } cm = 1 \text{ mm} = \frac{1}{10} \text{ cm} = 0.1 \text{ cm or } .1 \text{ cm}$$

7.11.1 Place Value in Decimal Number

If we read a three digit number then we can find the number by deciding the place value of the digits. Lets take 3 digits as an example: 1, 2, 5.

In the number 512 if 5 takes the place of the hundreds then it has the value 500. That is why 512 is five hundred and twelve. In the number 152 the numeral 5 is in tens place so it has the place value of fifty. In 125 we have 5 in the place of units. That is why the number is one hundred twenty and five or one hundred and twenty five.

If we move to the right of hundreds we have tens and if we move to the right side of tens it is units. In other words while shifting towards right the value of place becomes $\frac{1}{10}$ of its value.

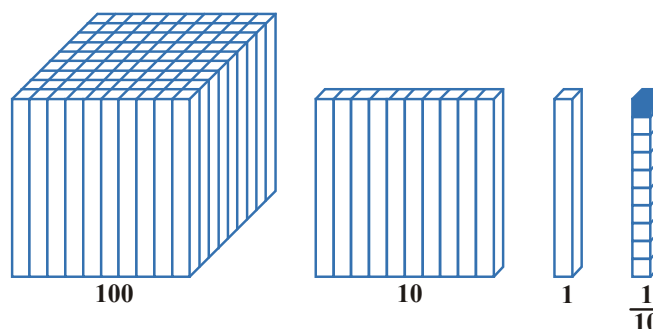

The picture above shows how as we move right the value becomes $\frac{1}{10}$ th of the value on the left. The first figure, We start 100 with a cube for 100 made up of 100 cuboidal rods. If we divide it into 10 equal parts then you will get a cuboid made up of 10 rods

When we further divide a ten in to 10 equal parts we get 1 cuboidal rod. This means that 10th part of a hundredth is tens and 10th part of tens is a unit.

Now, if we move more towards right then what will happen?

You must remember that in above diagram of measuring fish example we measured length less than 1 cm. We divided 1 cm. into 10 small equal parts. Each part is called of 1 mm. That is each part is $\frac{1}{10}$ cm. When we write mm in cm then we write it on the right hand side of the decimal point. The value of the first digit on the right hand side of the decimal point is $\frac{1}{10}$

$$100 \rightarrow \frac{100}{10} = 10 \rightarrow \frac{10}{10} = 1 \rightarrow \frac{1}{10}$$

If we have five 10th parts we have $\frac{5}{10}$ and write 0.5. This means 5 parts out of the 10 of a whole i.e., $\frac{5}{10} = 0.5$



TRY THESE

- i) Write fractions for the following decimal and also find how many tenth parts are there in each:

0.4 , 0.2 , .8 , 1.6 , 5.4 , 555.3 , 0.9

- ii) Complete the following table.

Tens (10)	Ones (1)	One-Tenths (1/10)	Decimal number
3	5	7	
6	9	4	
7	6	3	

- iii) Complete the following table.

Decimal Number	Whole number part	Decimal part	Value of the Decimal part	Write in words
8.5				
14.7				
23.0				

iv) Measure the length of these line segments and fill it in the table given below.

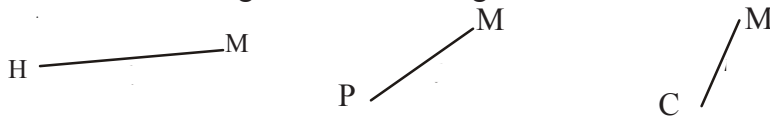

What you measured	cm and mm	Length measurement in cm	Length measurement in decimal
Line segment \overline{HM}			
Line segment \overline{PM}			
Line segment \overline{CM}			
Your eraser			
Piece of a chalk			
Your fore finger			

If part of 100 is to be shown then we have to write the number after two places to the right side of the decimal like $\frac{5}{100} = 0.05$ that is, if we move one place towards right from $\frac{1}{10}$ then the value is $\frac{1}{100}$.

1 m. has 100 cm in it. If we have to write 5 cm in meter then we write .05 m. If we have to write 25 cm. or hundredth part is to be written, then it is 0.25

$$\text{that is } \frac{20}{100} + \frac{5}{100} = \frac{25}{100} = 0.25$$

Write fractions for the following decimal and find how many hundredth parts are there in it:

0.35, 0.08, 6.70, 23.53, 756.01

Similarly we know 100 paise = 1 Rupee, so how much is 10 paise of a rupee and how much is 1 paise of rupee?

How much is 475 paise? It is $400 + 75$ paise or $4 + \frac{75}{100}$ rupee = ₹ 4.75. Also written as 4 rupees 75 paise (or) ₹ 4.75

Similarly rupees 5 and 30 paise will be written as $5\frac{30}{100}$ rupees which ₹ 5.30



DO THIS

Fill in the blanks:

- 325 paise = rupees paise = ₹
- 570 paise = rupees paise = ₹
- 2050 paise = rupees paise = ₹



EXERCISE - 7.4

- Fill in the blanks
 - The fractional form of 0.8 is _____
 - The Integral part of 15.9 is _____
 - The digit in the tenths place of 171.9 is _____
 - The place value of 8 in 9.8 is _____
 - The point between the Integral part and the decimal part of the decimal number is called _____
- Write the decimal for each of the following
 - One hundred twenty five and four tenths
 - Twenty and two tenths
 - Eight and Six tenths
- Write the following fractions in the decimal form using the decimal point.
 - $\frac{16}{100}$
 - $\frac{278}{1000}$
 - $\frac{6}{100}$
 - $\frac{369}{100}$
 - $\frac{16}{1000}$
 - $\frac{345}{10}$
 - $\frac{907}{100}$
- Write the place value of each underlined digit.
 - $3\underline{4}.26$
 - $8.\underline{8}8$
 - $0.\underline{9}1$
 - $0.\underline{5}0$
 - $3.0\underline{3}$
 - $6.\underline{7}4$
- Find greater in the following.
 - 0.2 or 0.4
 - 70.08 or 70.7
 - 6.6 or 6.58
 - 7.4 or 7.35
 - 0.76 or 0.8
- Rewrite in ascending order
 - 0.04, 1.04, 0.14, 1.14
 - 9.09, 0.99, 1.1, 7
- Rewrite in descending order
 - 8.6, 8.59, 8.09, 8.8
 - 6.8, 8.66, 8.06, 8.68

7.12 ADDITION AND SUBTRACTIONS OF DECIMAL FRACTIONS

Add 0.3 and 0.4

Take a circle and divide it into 10 equal parts.

Shade 3 equal parts to represent 0.3

Shaded 4 equal parts in a different way to represent 0.4

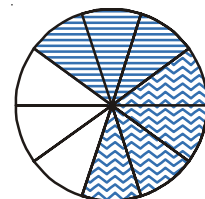

	Ones	Tenths
	0	. 3
+	0	. 4
	0	. 7

Therefore $0.3 + 0.4 = 0.7$

Thus, we can add decimal in such a manner that tenth part will add to tenth part of the second number. Similarly the hundredth parts would be added together.

Can you now add 0.63 and 0.54?

	Ones	Tenths	Hundredths
	0	. 6	3
+	0	. 5	4
	1	. 1	7

Thus $0.63 + 0.54 = 1.17$

Do This

Find:

(i) $0.39 + 0.26$

(ii) $0.8 + 0.07$

(iii) $1.45 + 1.90$

(iv) $3.44 + 1.58$

Example-1. Add $3.64 + 5.4$

Method-(i): $3.64 + 5.4$ The first is two decimal place fraction and the second is a one decimal place fraction

$= 364/100 + 54/10$ Express them in the fractional form

$= 364/100 + 540/100$ Make 100 the denominator of the second fraction.

$= 904/100$ Add the numerators after making the denominators equal.

$= 9.04$ Write the answer using the decimal point.

Method-(ii): $3.64 + 5.4$

	Units	Tenths	Hundredths
	3	. 6	4
+	5	. 4	
	9	. 0	4

3.64	As the first fraction has two decimal places
+ 5.40	convert 5.4 into a two decimal place fraction and add.
<u>9.04</u>	

Example-2. Salma is practising for her school sports day. She runs 3.27 km. in the morning and 2.8 km. in the evening. How much does she run in all?

Solution: $3.27 + 2.8 = ?$

Run in the morning	=	3.27 km
Run in the evening	=	2.80 km
Total distance run	=	6.07 km

Example-3. Subtract 1.23 from 2.85

Solution: This can be shown by the table

Ones	Tenths	Hundredths
2	8	5
-	1	2
1	6	2

Thus $2.85 - 1.23 = 1.62$

Therefore, we can say that, subtraction of decimals can be done by subtracting hundredths from hundredths, tenths from tenths, ones from ones and so on. Just as we added in addition.

Sometimes while subtracting decimals, we may also need to regroup.

Example-4. Subtract 2.89 from 4.5

Solution:

Ones	Tenths	Hundredths
4	5	0
-	2	8
1	6	9

Therefore $4.5 - 2.89 = 1.61$



EXERCISE - 7.5

1. Sonu went to a shop. He wanted to buy a chiki and a toffee. One chiki costs ₹0.75 and a toffee costs ₹0.50. If he buys one each of them how much he has to pay to the shop keeper. Sonu's mother gave him ₹2. How much he will get in return? Suppose if his mother gave her ₹5 then how much will the shopkeeper return?
2. Add the following decimal fractions:

(i) $25.11 + 3.80$	(ii) $14.01 + 1.1 + 1.98$
(iii) $9.85 + 0.61$	(iv) $2.3 + 18.94$
(v) $2.57 + 3.75$	
3. Abhishek travelled 5 km. 28 m. by bus, 2 km. 265 m. by car and the rest 1 km. 30 m. on foot. How much distance did he travel in all?
4. Mrs. Vykuntam bought 6.25 m of dress material for her elder daughter and 5.75 m for the



WHAT HAVE WE DISCUSSED?

- A fraction is a number representing a part of a whole. The whole may be a single object or a group of objects.
 - When expressing a situation of counting parts to write a fraction, it must be ensured that all parts are equal.
- In $\frac{5}{7}$, 5 is called the numerator and 7 is called the denominator.
- Fractions can be shown on a number line. Every fraction has a point associated with it on the number line.
- In a proper fraction, the numerator is less than the denominator. The fractions, where the numerator is greater than the denominator are called improper fractions. An improper fraction can be written as a combination of a whole and a part and such fractions are called mixed fractions.
- Each proper or improper fraction has many equivalent fractions. To find an equivalent fraction of a given fraction, we may multiply or divide both the numerator and the denominator of the given fraction by the same number.
- A fraction is said to be in the standard (or lowest) form if its numerator and the denominator has no common factor except 1.
- To understand the parts of one whole (i.e. a unit) we represent a unit by a cuboidal bar.

One cuboidal bar is divided into 10 equal parts means each part is $\frac{1}{10}$ (one-tenth) of a unit. It can be written as 0.1 in decimal notation. The dot represents the decimal point and it comes between the units place and the tenths place.

- Every fraction with denominator 10 and its multiples can be written in decimal notation and vice-versa.
- One block divided into 100 equal parts means each part is $\frac{1}{100}$ (one-hundredth) of a unit. It can be written as 0.01 in decimal notation.
- In the place value table, as we go from left to the right, the multiplying factor becomes $\frac{1}{10}$ of the previous factor.

The place value table can be further extended from hundredths to $\frac{1}{10}$ of hundredths i.e.

thousandths $\frac{1}{1000}$, which is written as 0.001 in decimal notation.

- All decimals can also be represented on a number line.
- Any two decimal numbers can be compared among themselves. The comparison can start with the whole part. If the whole parts are equal then the tenth part can be compared and so on.
- Decimals are used in many ways in our lives. For example, in representing units of money, length and weight.





8.1 INTRODUCTION

Siri's father wants to buy a mobile phone. He asks his friends about the different types of models available in the market and writes their prices and features in the form of table:



Features	Brand-1 Mobile	Brand-2 Mobile	Brand-3 Mobile
Price	₹1500	₹1200	₹2000
MP3	✓	✓	✓
Camera	✗	✗	✓
Bluetooth	✗	✗	✓
Alarm	✓	✓	✓
FM	✓	✗	✓
Guarantee period	1 year	3 months	6 months

Siri asked her father, why he prepared the table? Her father replied, "I want to buy a mobile. To find a model that suits my needs, I have to compare the features of the different models. So I have collected all the information and then organised in the form of a table." Siri liked the idea.

For taking the right decision it is often necessary to collect information and organise it. Numeric data is a collection of numbers gathered to give some information.

Information either in the form of numbers or words, which helps us to take decisions is called data.

In the above example, the price of the mobile phones, the presence or absence of a camera in cell phone, the presence and absence of FM in cellphones etc., is all data. In our daily life we come across several situations where we collect information to take decisions.

Let us consider one more example.

Manager of a shoe factory decided to increase his sales. He has to decide the size of shoe is to be produced in more number. For this he conducted a survey among 500 people and got the data like this.

Shoe size	7	8	9	10	11	Total
Number required	42	126	278	44	10	500

Looking at the data the manager can decide the size of the shoes to be produced in more number and the size of the shoe to be produced in less number.

8.2 COLLECTION AND RECORDING OF DATA

Laxmi is preparing to go for a picnic with her friends. She has to take fruits for everybody in the picnic. Laxmi's mother asked her to find the required number of fruits of each type. Laxmi prepared a list like this:

Person	Like to have
Laxmi	Orange
Preeti	Guava
Radha	Orange
Uma	Custard apple
Reshma	Guava
Mary	Orange
Latha	Orange
Gouri	Banana
Salma	Custard Apple
Rita	Guava



TRY THESE

- Give two examples of data in numerical figures.
- Give two examples of data in words.

She gave the list to her mother. Her mother read the list. To find the number of fruits required for each type, first counted the number of oranges by going overall names in the list. She then repeated this process for Guavas, then bananas and then custard apples. She finally wrote as

Oranges - 4, Guava - 3, Banana - 1, Custard apple - 2

Here Oranges came 4 times. So 4 is called the frequency of an Orange. Similarly frequency of Guava is 3

Would it have been so easy for Laxmi's mother to count if the number of children in class had been 50? What do you think?

Laxmi's mother needs a way in which she can count all the fruits simultaneously.

8.3 ORGANISATION OF DATA

In Census 2001, an enumerator collected information about the family size of 55 families in a habitation. He asked some students to help him to organise the data.

All students used tally marks to organize the data, but used them differently.

Poorna made tally marks like this:

Family size	Tally marks	Number of families
2		6
3		19
4		23
5		5
6		2

Rahim encircled every ten tally marks into a group:

Family size	Tally Marks	Number of families
2		6
3		19
4		23
5		5
6		2

Dinesh encircled 5 tally marks into a group.

Family size	Tally Marks	Number of families
2		6
3		19
4		23
5		5
6		2

Chetan also encircled 5 tally marks but did so differently. He marked 4 tally marks as a square and the fifth tally mark as a diagonal.

Family size	Tally Marks	Number of families
2	□	6
3	□ □ □ □	19
4	□ □ □ □ □	23
5	□	5
6	└	2

Sarala made tally marks by crossing every four tally marks with a fifth tally mark.

Family size	Tally Marks	Number of families
2	≡	6
3	≡ ≡ ≡	19
4	≡ ≡ ≡ ≡	23
5	≡	5
6		2

The manner in which Sarala has made the tally marks is generally used to obtain the frequency or the count of the data items. A table showing the frequency or count of various items is called a frequency distribution table.

Example-1. 25 students in a class got the following marks in an assignment- 5, 6, 7, 5, 4, 2, 2, 9, 10, 2, 4, 7, 4, 6, 9, 5, 5, 4, 7, 9, 5, 2, 4, 5, 7. The assignment was for 10 marks.

- (i) Organise the data and represent in the form of a frequency distribution table using tally marks.
- (ii) Find out the marks obtained by maximum number of students.
- (iii) Find out how many students received least marks.
- (iv) How many students got 8 marks?

Solution:

(i)	Marks obtained	Tally Marks	Number of Students
	2		4
	4		5
	5		6
	6		2
	7		4
	9		3
	10		1

- (ii) Marks obtained by maximum number of students (6) = 5
- (iii) Number of students who received least marks (2) = 4
- (iv) Number of students who got 8 marks = 0.



EXERCISE - 8.1

1. A child's Kiddy bank is opened and the coins collected are in the following denomination.

Type of coin

Number of coins

50 Piasa



1 Rupee



2 Rupees



5 Rupees



2. The favourite colours of 25 students in a class are given below:
Blue, Red, Green, White, Blue, Green, White, Red, Orange, Green, Blue, White, Blue, Orange, Blue, Blue, White, Red, White, White, Red, Green, Blue, Blue, White.
- Write a frequency distribution table using tally marks for the data. Which is the least favourite colour for the students?
3. A TV channel invited a SMS poll on 'Ban of Liquor' giving options :
A - Complete ban B - Partial ban C - Continue sales
- They received the following SMS, in the first hour-
- | | | | | | | | | | |
|---|---|---|---|---|---|---|---|---|---|
| A | A | B | C | A | B | B | C | A | A |
| A | A | C | C | B | A | A | C | B | A |
| A | A | A | B | B | C | C | A | A | C |
| C | B | B | B | A | A | A | A | A | C |
- Represent the data in a frequency distribution table using tally marks.
4. Vehicles that crossed a checkpost between 10 AM and 11 AM are as follows:
car, lorry, bus, lorry, auto, lorry, lorry, bus, auto, bike, bus, lorry, lorry, zeep, lorry, bus, zeep, car, bike, bus, car, lorry, bus, lorry, bus, bike, car, zeep, bus, lorry, lorry, bus, car, car, bike, auto.
- Represent the data in a frequency distribution table using tally marks.

Play the game







Take a die. Throw it and record the number. Repeat the activity 40 times and record the numbers. Represent the data in a frequency distribution table using tally marks.

8.4 REPRESENTATION OF DATA

Data that has been organised and presented in frequency distribution tables can also be represented using pictographs and bar graphs.

8.4.1 Pictographs

A book-shelf has books of different subjects. The number of books of each subject is represented as a pictograph given below. Observe them.

Subject	Number of books
Telugu	
English	
Hindi	
Maths	
Science	
Social	

- i) Which books are more in number?
- ii) Which books are least in number?
- iii) How many books are there in all?





We can answer these questions by studying the pictograph. A pictograph uses pictures or symbols to represent the frequency of the data.

Now, let us represent the strength of a school in the form of a pictograph.





Class	VI	VII	VIII	IX	X
Number of Students	28	30	35	25	22

Is it reasonable to represent 35 students using 35 symbols? To draw the pictograph conveniently, in such situations we can assume that 5 students can be represented by one symbol. This is called scaling. Generally the scale must be the Greatest Common Divisor of all the frequencies.

In case the frequency is less than the scaling unit, we must make appropriate assumptions. In the above example:





- If  represents 5 students
 represents 4 students
 represents 3 students
 represents 2 students
 represents 1 student.

Now, let us construct a pictograph for the data given above-

Class	Number of Students
VI	
VII	
VIII	
IX	
X	

Example-1. In a class of 25, students like various games. The details are shown in the following pictograph. (No student plays more than one game).

- i) How many students play badminton?
- ii) Which game is played by most number of students?

Game	Number of Students
Kabaddi	
Tennikoit	
Badminton	
Cricket	





- iii) What is the game in which least number of students are interested?
 iv) How many students do not play any game?

Solution:

- 5 students play badminton.
- Kabaddi is played by most number of students i.e. 7.
- Tennikoit is played by least number of students i.e. 4.
- Total number of players = $7 + 4 + 5 + 6 = 22$
 Number of students in the classroom = 25
 Thus, number of students who do not play any game = $25 - 22 = 3$

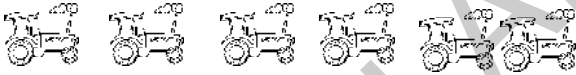
Example-2. The following pictograph shows the number of tractors in five different villages.

Scale :  = 2 Tractors

Village	Number
A	
B	
C	
D	
E	

- Which village has the minimum number of tractors?
- Which village has the maximum number of tractors?
- How many more tractors does village C has when compared to village B.
- What is the total number of tractors in all the five villages?

Solution:

- Village B and E have the minimum number of tractors, 8 tractors each.
- Village D has the maximum number of tractors, 20 tractors.
- Village C has 10 tractors more than B.
- There are 66 tractors in all in the village.



EXERCISE - 8.2

1. The number of wrist watches manufactured by a factory in a week are as follows:

Day	Monday	Tuesday	Wednesday	Thursday	Friday	Saturday
No. of watches	300	350	250	400	300	275

Represent the data using a pictograph. Choose a suitable scale.

2. Details of fruits sold in a week by Ahmed, a fruit vendor are given here under. Prepare a pictograph for the data: [Scale: Represent 5 fruit with a symbol]

Day	Sunday	Monday	Tuesday	Wednesday	Thursday	Friday	Saturday
No. of fruits sold	100	85	90	80	60	95	70

Answer the following questions:





- How many symbols represent the fruits sold on Tuesday?
 - How many symbols represent the fruits sold on Friday?
3. Votes polled for various candidates in a sarpanch election are shown below, against their symbols in the following table.

Symbol				
Number of votes	400	550	350	200

Represent the data using a pictograph. Choose a suitable scale.

Answer the following questions:

- Which symbol got least votes?
 - Which symbol's candidate won the election?
4. The following pictograph shows the number of students having cycles, in five classes of a school.





Class	Number of cycles
VI	
VII	
VIII	
IX	
X	

Answer the following questions based on the pictograph given above-

- Which class students have the maximum number of cycles?
- Which class students have the minimum number of cycles?
- Which class students have 9 cycles?
- What is the total number of cycles in all the five classes?

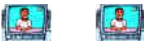
5. The sale of television sets of different companies on a day is shown in the pictograph given below.

Scale :  = 5 televisions

Company	Number of television sets sold
A	
B	
C	
D	
E	

Answer the following questions:

- How many TVs of company A were sold?
 - Which company's TVs did people like more?
 - Which company sold 15 TV sets?
 - Which company had the least sale?
6. Monthly salaries of 5 workers are shown in the pictograph given below:

Scale :  = 1000 rupees

Worker	Monthly Salary
Ramesh	
Vilas	
Venkat	
Dinesh	
Sachin	

Answer the following questions:

- What is the scale used in the pictograph?
- How much is Sachin's salary?
- Who earns more salary?
- How much is Ramesh's salary more than Vilas's?



PROJECT WORK

Collect as many pictographs as possible from news papers and magazines and study them carefully.

8.4.2 Bar Graph

Akash collected data about the qualifications of 275 persons in his locality. He organised the data into a frequency distribution table:

Education Level	Number of Persons
Primary Education	109
Secondary Education	72
Intermediate	56
Graduation	31
Post graduation	7

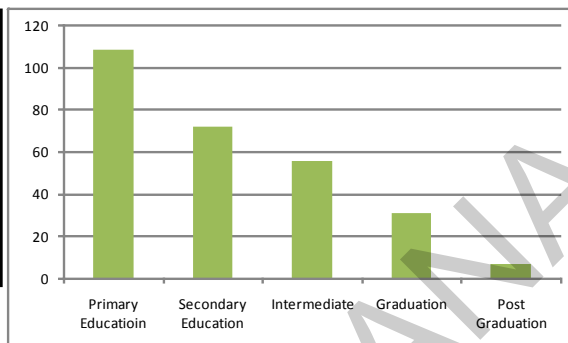

He tried to represent the data using a pictograph. But he found that this is not only time consuming but also difficult. So he decided to use bar graph, which is shown aside.

Generally bar graphs are used to represent independent observations with frequencies.

In bar graph, bars of uniform width are drawn horizontally or vertically with equal spacing between them. The length of the bars represents the frequency of the data items

From the above bar graph we can observe that most people have not studied beyond school. It also shows that a very few people hold post graduate degrees.

THINK, DISCUSS AND WRITE

In what way is the bar graph better than the pictograph?



Construction of a bar graph

The professions of people living in a colony are given in the following table:

Profession	Farmers	Businessmen	Private Employee	Govt. Employee	Labourers
No. of persons	40	10	15	35	5

To represent the above data in the form of a vertical bar diagram, the steps are given below:

- Draw two perpendicular lines—one horizontal (X-axis) and one vertical (Y-axis).
- Along the Y-axis mark 'number of people' and along the X-axis mark 'professions'.
- Select a suitable scale on the Y-axis, say 1 cm = 5 persons.

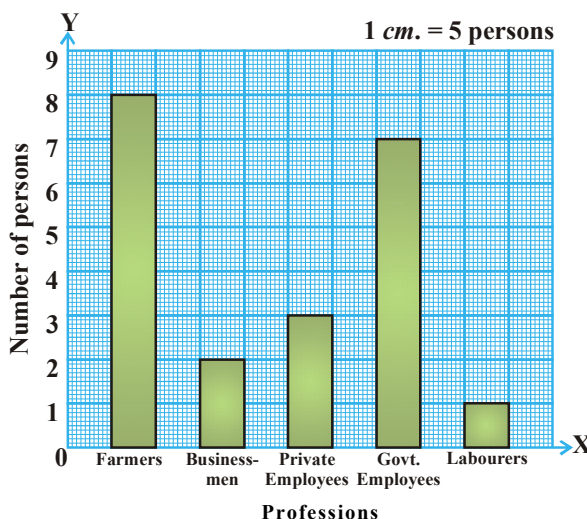

- (iv) Calculate the heights of the bars by dividing the frequencies with the scale:
- | | | | |
|-------------------|-----------------|-----------------|-----------------|
| Farmers | $40 \div 5 = 8$ | Businessman | $10 \div 5 = 2$ |
| Private Employees | $15 \div 5 = 3$ | Govt. Employees | $35 \div 5 = 7$ |
| Labourers | $5 \div 5 = 1$ | | |
- (v) Draw rectangular, vertical bars of same width on the X-axis with heights calculated above.
- Similarly we can construct a horizontal bar diagram for the data given above.

Steps of construction:

- (i) Draw two perpendicular lines on a graph sheet -one horizontal (X-axis) and one vertical (Y-axis).
- (ii) Along the X-axis mark 'number of persons' and along the Y-axis mark 'professions'.
- (iii) Select a suitable scale on the X-axis, say 1 cm = 5 persons.
- (iv) Calculate the lengths of the bars by dividing the frequencies with the scale:
- | | | | |
|-------------------|-----------------|-----------------|-----------------|
| Farmers | $40 \div 5 = 8$ | Businessmen | $10 \div 5 = 2$ |
| Private Employees | $15 \div 5 = 3$ | Govt. Employees | $35 \div 5 = 7$ |
| Labourers | $5 \div 5 = 1$ | | |
- (v) Draw rectangular, horizontal bars of same width on the Y-axis with lengths calculated above.

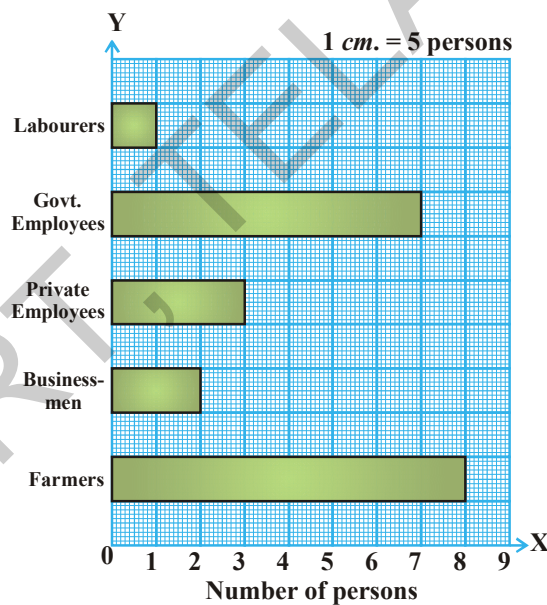

EXERCISE - 8.3

1. The life span of some animals is given as follows:
 Bear - 40 years, Bull - 28 years, Camel - 50 years, Dog - 22 years, Cat - 25 years,
 Donkey - 45 years, Goat - 15 years, Horse - 10 years, Cow - 22 years, Elephant - 70 years.

2. The following table shows the monthly expenditure of Imran's family on various items:

Item	House Rent	Food	Education	Electricity	Transport	Misc.
Expenditure (₹)	3000	3400	800	400	600	1200

Construct a vertical bar diagram to represent the above data.

3. Travelling time from Hyderabad to Thirupathi by different means of transport are-
Car - 8 hours, Bus - 15 hours, Train - 12 hours, Aeroplane - 1 hour. Represent the information using a bar diagram.
4. A survey of 120 school students was conducted to find which activity they prefer to do in their free time.

Preferred activity	Playing	Reading story books	Watching TV	Listening to music	Painting
Number of students	45	30	20	10	15

Draw a bar graph to illustrate the above data.



PROJECT WORK

1. Collect different kinds of bar graphs from news papers, magazines etc. and make an album. Try to interpret each of the bar graphs.
2. Go round your colony. Note how many houses of different kinds i.e. thatched houses, tiled houses, RCC slab houses, apartments are there. Tabulate the findings and represent the data as a bar graph.



WHAT HAVE WE DISCUSSED?

1. Information either in the form of number or words, which helps us to take decisions is called data.
2. To get a particular information from the given data quickly, the data can be arranged in a tabular form using tally marks.
3. We learnt how a pictograph represents data in the form of pictures, objects or parts of objects. We have also seen how to interpret a pictograph and answer the related questions. We have drawn pictographs using symbols to represent a certain number of items or things. For example,  = 100 books.
4. We have discussed about representation of data by using a bar diagram or a bar graph. In a bar graph, bars of uniform width are drawn horizontally or vertically with equal spacing between them. The length of each bar represents the respective frequency.



P. C. Mahalanobis (1893-1972)

Founder of Indian Statistical Research Institute in Kolkatta. He is known as father of Indian statistics. His 'National Sample Surveys' have gained international recognition.





Introduction to Algebra 9

9.1 INTRODUCTION

Our study so far has been with numbers and shapes. What we have learnt so far comes under arithmetic and geometry. Now we begin the study of another branch of mathematics called Algebra.

The main feature of algebra is the use of letters or alphabet to represent quantities. Letter can represent any number, not just a particular number. It may stand for an unknown quantity. By learning the method of determining unknowns we develop powerful tools for solving puzzles and many problems in our daily life.

Consider the following discussion

Damini and Koushik are playing a game.

Koushik : If you follow my instructions and tell me the final result, then I will tell you your age.

Dhamini : But you know my age, so what is new?

Koushik : Ok, take the age of a person who is unknown to me. Do not reveal me the age but still I will tell you the age.

Dhamini : Alright, what are your instructions? Let me see how you do it.

Koushik : First, double the age.

Dhamini : Done.

Koushik : Add 5 to the result and tell me the final result.

Dhamini : Ok, the result is '27'.

Koushik : Good! Your friend's age is 11 years.

Dhamini was surprised. She thought for a while and said 'I know how you found the age'.

Do you know how it was done? You too can try!!!

9.2 PATTERNS - MAKING RULES

9.2.1 Pattern-1

Praveen and Moulika were making human faces as shown in the following figures. They use black stickers for eyes. Moulika took two black stickers and formed a human face as shown in the figure.

Praveen also took two black stickers to form a human face and put it next to the one made by Moulika.

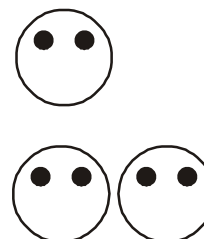

Then Moulika added one more

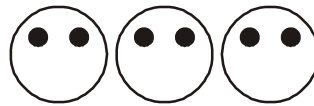

and Praveen also

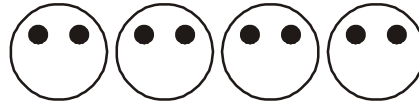

Soon after their friend Rahim joined them. He asked them, " How many black stickers will be required to form 8 such shapes". Immediately Moulika counts the number of black stickers in four shapes, doubles the number and says 16.

"Well" Rahim said and asks them, " How many black stickers will be required to form 69 such human faces". Moulika and Praveen feel this method of counting stickers is a bit laborious and time consuming, specially when the number of faces are very large. They decide to find a new way. They think a while and make the following table.

Number of human faces formed	1	2	3	...
Number of black stickers required	2	4	6	...
Also represented as (pattern formation)	2×1	2×2	2×3	...

Do you notice a relation between the number of faces formed and the number of black stickers required? Moulika says that there is a relationship between the number of faces to be formed and the number of black stickers required.

For example to make 1 face, the required stickers are 2 i.e. 2×1 or $2 \times$ the number of faces formed. Let us see if it works for larger number of faces.

For 2 faces, the required stickers are $4 = 2 \times 2 = 2 \times$ number of faces formed.

For 3 faces, the required stickers are $6 = 2 \times 3 = 2 \times$ number of faces formed.

Moulika said that the number of black stickers required is twice the number of faces formed i.e. number of black stickers required = 2 times the number of faces formed.

Now for the number of faces to be 69 we require. $2 \times 69 = 138$ black stickers.

9.2.2 Pattern-2

To make a triangle, 3 matchsticks are used.

If we want to make two triangles we need 6 matchsticks.

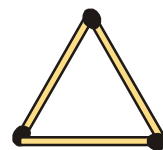
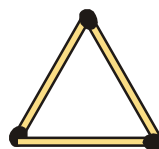
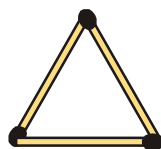

The following table gives the number of matchsticks required and the number of triangles to be formed:

Number of triangles	1	2	3	4	5	6	...
Number of matchsticks required	3	6	9	12	15	18	...
Observation (Pattern)	3×1	3×2	3×3	3×4	3×5	3×6	...

What is the rule for the number of triangles formed and the matchsticks needed?

The rule is number of matchsticks required = 3 times the number of triangles to be formed.

9.2.3 Pattern 3

To make a square, 4 matchsticks are needed.

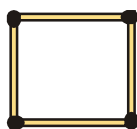

If we want to make two squares we need 8 matchsticks

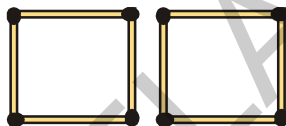

If we want to make three squares we need 12 matchsticks



Let us arrange the above information in the following table

Number of squares	1	2	3
Number of matchsticks required	4	8	12
Observation (Pattern)	4×1	4×2	4×3

i.e. number of matchsticks required = 4 times number of squares ($4 \times$ number of squares)

9.3 VARIABLE

Let us consider the table in pattern-1

Number of human faces	1	2	3	...
Number of black stickers required	2	4	6	...
Pattern	2×1	2×2	2×3	...

In the table as the number of human faces formed goes on increasing the number of black stickers required also goes on increasing. Also notice that in each case the number of stickers required is twice the number of human faces formed.

For the sake of convenience, let us write a letter say 'm' for the number of faces formed.

Therefore, number of black stickers required = $2 \times m$. Instead of writing " $2 \times m$ " we write "2m". Note that "2m" is same as " $2 \times m$ " not as $2 + m$.

\therefore The number of black stickers required = $2m$.

If we want to make one human face, the value of $m = 1$. Therefore according to the rule the number of stickers required is $2 \times 1 = 2$.

If we want to make two faces, the value of 'm' becomes 2. Therefore the number of stickers required is $2 \times 2 = 4$.

Now, can you guess the number of stickers required for three faces? Obviously 6.

From the above example we found relation between the number of stickers required and the number of faces.

Number of stickers required = $2m$

Here m is the number of faces and it can take any value i.e. 1, 2, 3, 4,

The 'm' here is an example of a variable, the value of 'm' is not fixed and it can take different values. Accordingly the number of stickers also changes.

Now consider the table of pattern-2

Number of triangles	1	2	3	4	5	6
Number of matchsticks required	3	6	9	12	15	18
Observation (Pattern)	3×1	3×2	3×3	3×4	3×5	3×6

Now can you frame the rule for the number of match sticks required for a given number of triangles to be formed?

Obviously number of match sticks required = $3y$, where 'y' is number of triangles. Here also 'y' takes different values. $y = 1, 2, \dots$ i.e. the value of 'y' changes. Hence 'y' is an example of a variable.

Go back to the table of pattern -3 and make the rule for the number of match sticks required for a given number of squares. Take n to denote the number of squares and m to denote the matchsticks needed.



TRY THESE

- Can you now write the rule to form the following pattern with match sticks?



- Find the rule for required number of match sticks to form a pattern repeating 'H'. How would the rule be for repeating the shape 'L'?

9.4 MORE PATTERNS

Consider the matchstick pattern constructing squares

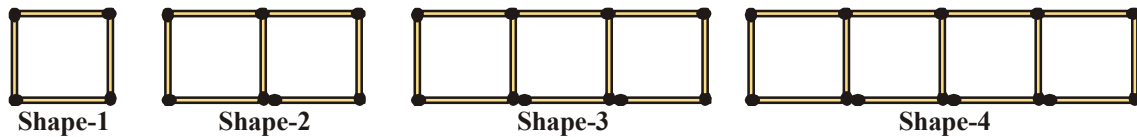

The number of squares and the matchsticks required are given below:

Number of squares	1	2	3	4	5
Number of matchsticks	4	7	10	13	---
Pattern	$(3 \times 1) + 1$	$(3 \times 2) + 1$	$(3 \times 3) + 1$	$(3 \times 4) + 1$	---

Then the rule is, number of matchsticks = $3 \times (\text{number of squares}) + 1$

Let s = number of squares, therefore number of matchsticks used = $(3 \times s) + 1 = 3s + 1$

Here the letter 's' is an example for a variable.



TRY THESE

Observe the number of matchsticks required to arrange the following pattern.

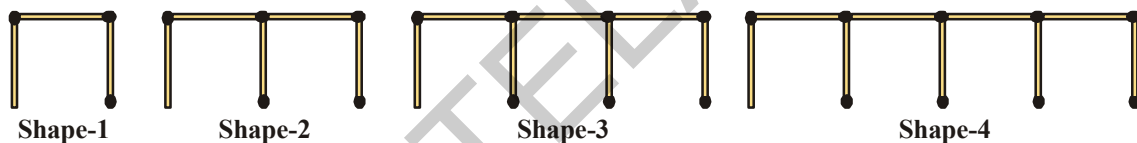

- Find the rule that shows how many sticks are needed to make a group of such shapes?
- How many matchsticks are needed to form a group of 12 shapes?

We can use any letter eg. m, n, p, s, x, y, z etc. to denote a variable. Variable does not have a fixed value or a fixed letter attached to it. A letter can denote any quantity. In the above examples we have used m, y, s to denote the number of matchsticks.

Example-1. Number of pencils with Rama is 3 more than Rahim. Find the number of pencils Rama has in terms of what Rahim has?

Solution: If Rahim has 2 pencils then Rama has $2 + 3 = 5$ pencils.

If Rahim has 5 pencils then Rama has $5 + 3 = 8$ pencils.

We do not know how many pencils Rahim has.

But we know that Rama's pencils = Rahim's pencils + 3

If we denote the number of pencils Rahim has as n , then the number of pencils of Rama are $n+3$

Here $n = 1, 2, 3, \dots$ therefore 'n' is a variable.

Example-2. Hema and Madhavi are sisters. Madhavi is 3 years younger to Hema. Write Madhavi's age in terms of Hema's age?

Solution: Given that Madhavi is younger to Hema by 3 years,
 If Hema is 10 years old then Madhavi is $10 - 3 = 7$ years old.
 If Hema is 16 years old, Madhavi is $16 - 3 = 13$ years old.

Here we don't know the exact age of Hema. It may take any value.

So let the age of Hema be 'p' years, then Madhavi's age is "p - 3" years.

Here 'p' is also an example of a variable. It takes different values like 1,2,3... As you would expect when 'p' is 10, 'p-3' is 7 and when 'p' is 16, p-3 is 13.

 **EXERCISE - 9.1**

- Find the rule which gives the number of matchsticks required to make the following matchsticks patterns.
 (i) A pattern of letter 'T' (ii) A pattern of letter 'E' (iii) A pattern of letter 'Z'
- Make a rule between the number of blades required and the number of fans (say n) in a hall?
- Find a rule for the following patterns between number of shapes formed and number of matchsticks required.

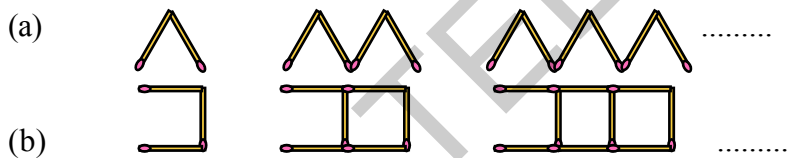
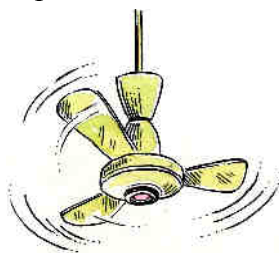

- The cost of one pen is ₹ 7 then what is the rule for the cost of 'n' pens.
- The cost of one bag is ₹ 90 what is the rule for the cost of 'm' bags?
- The rule for purchase of books is that the cost of q books is ₹ 23q ; then find the price of one book?
- John says that he has two books less than Gayathri. Write the relationship using variable x.
- Rekha has 3 books more than twice the books with Suresh. Write the relationship using variable y.
- A teacher distributes 6 pencils per student. Can you find how many pencils are needed for the given number of students (use 'z' for the number of students).
- Complete each table to generate the given functional relationship.

i)	x	1	2	3	4	5	9
	$3x+2$	5	38
ii)	a	1	3	6	7	9	8
	$5a-1$	4	49

11. Observe the following pattern.



Shape-1



Shape-2

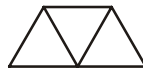

Shape-3

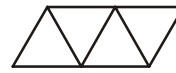

Shape-4

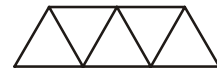

Shape-5

Count the number of line segments in each shape.

- How many line segments will the ninth shape contain?
- Write the rule for the above pattern.

9.5 EXPRESSIONS WITH VARIABLES

Recall that in arithmetic we have come across expression like $5 + 4$, $11 - 9$, $3 + 0$ etc. These are all formed using numbers. Observe the following.

Ram says that he has scored five marks more than Tony. Can you find the marks scored by Ram? Here we do not know the marks of Tony. We proceed by supposing Tony's marks.

Suppose Tony scored 45 marks. Then marks scored by Ram would be $45 + 5 = 50$

If Tony scored 56 marks. Then marks scored by Ram would be $56 + 5 = 61$

Now let us suppose Tony scored 'x' marks. Can you say the marks scored by Ram?

The marks scored by Ram would be $x + 5$, which is an expression with variable 'x'.

In fact, we have seen expressions like $2m$, $3y$, $4z$, $2s + 1$, $3s + 1$, $8p$, $n + 3$, $p - 3$ in the earlier discussion. Those expressions are obtained by using operations of addition, subtraction, multiplication and division of variables. For example, the expression ' $p - 3$ ' is formed by subtracting 3 from the variable 'p' and the expression ' $8p$ ' is formed by multiplying the variable 'p' by '8'.

We know that variables can take different values; they have no fixed value, but they are numbers. That is why operations of addition, subtraction, multiplication and division can be done on them.

We have already come across daily life situation in which expressions are useful. Let us recall some of them:

S.No.	Situation	Variable	Statement using Expression
(i)	'n' divided by 7		
(ii)	₹ 5 more than what Geeta has	Geeta has ₹ y	$y + 5$
(iii)	Perimeter is 4 times the side in a square		
(iv)	Price of apple is twice the price of guava		
(v)	Renu's height is 3 feet less than Leela's height		
(vi)	I have scored $\frac{1}{3}$ of the runs scored by you.		



TRY THESE

1. Find the general rule for the perimeter of a rectangle. Use variables ' l ' and ' b ' for length and breadth of the rectangle respectively.
2. Find the general rule for the area of a square by using the variable ' s ' for the side of a square.
3. What would be the rule for perimeter of an Isosceles triangle?

9.7 RULE FROM ARITHMETIC

Observe the following even number pattern

2, 4, 6, 8, 10,

To find the n th term in the given pattern, we put the sequence in a table

Even no. position	1st	2nd	3rd	4th	5th	6th	7th	8th	9th	10th
Even Number	2	4	6	8	10	12	14	16	18	20
Pattern	2×1	2×2	2×3	2×4	2×5	2×7	2×9

From the table it is clear that the first even number is 2×1 , the second even number is 2×2 and so on. Using the above logic, we can fill up the blanks in the table and find the pattern for ' n th' even number. It is $2 \times n$ i.e., ' $2n$ '.

So the n th term of the pattern 2, 4, 6, 8, 10, is $2n$.



DO THIS

1. Find the n th term in the following sequences
 - i) 3, 6, 9, 12,
 - ii) 2, 5, 8, 11,
 - iii) 1, 8, 27, 64, 125,

9.8 SIMPLE EQUATIONS

Let us recall the face pattern.

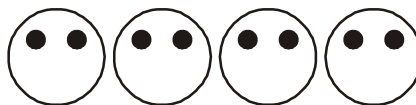

We know that the number of black stickers required is given by the rule $2m$, if m is taken to be the number of faces to be formed. We can find the number of stickers required for a given number of faces.

What about the other way? How to find the number of faces formed when the number of stickers are given. This means, we have to find the number of faces (i.e. m) for the given number of stickers 10.

For 10 stickers we know $2m = 10$. Here we have a condition to be satisfied by the

The condition to be satisfied that 2 times m must be 10 is example of an equation.

Our question can be answered by observing the table.

m	$2m$	Condition satisfied? (Yes/No)
2	4	No
3	6	No
4	8	No
5	10	Yes
6	12	No
7	14	No

The equation $2m = 10$ is satisfied only when $m = 5$.

9.8.1 L.H.S & R.H.S of an Equation

If we observe the equation $2m = 10$ we can find that equation has sign of equality between its two sides. The value of expression to the left of the equality sign ($2m$) in an equation is called Left Hand Side (LHS) and the value which is right side of the equality sign (10) is called Right Hand Side (RHS).

An equation says that the value of the LHS is equal to the value of RHS. This condition of an equation is often compared with a simple balance with equal weights on both pans.

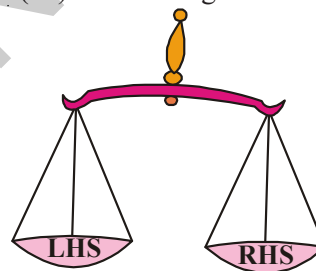

If LHS is not equal to RHS we do not get an equation. For example $4 + 5$ on one side and 7 on the other side is not an equation. We would write $4 + 5 \neq 7$ or $4 + 5 > 7$. Similarly $x + 5 > 6$, $y - 1 < 10$ are not equations.



Do This

- Write LHS and RHS of following simple equations:
(i) $2x + 1 = 10$ (ii) $9 = y - 2$ (iii) $3p + 5 = 2p + 10$
- Write any two simple equations and give their LHS & RHS.

9.8.2 Solution of an equation (Root of the equation)- Trial & Error Method

Let us take the other example considered at the beginning of the chapter. We observed a conversation between Damini and Koushik. In that conversation Damini said that the final result was 27 and Koushik told her friend's age as 11 years.

Let us see how he found the age.

Let Damini friend's age be ' x ' years. Doubling it we get ' $2x$ '. After adding 5 to it, it becomes ' $2x + 5$ ', which is equal to the final result 27 given by Damini.

$$\therefore 2x + 5 = 27$$

Let us take the above equation : Check for what value of x it is satisfied.

Here 'x' is a variable and can take any value like 1, 2, 3,

If $x = 1$ then the value of $2x + 5 = 2 \times 1 + 5 = 7$

If $x = 2$ then the value of $2x + 5 = 2 \times 2 + 5 = 9$

If $x = 3$ then the value of $2x + 5 = 2 \times 3 + 5 = 11$ and so on.

Writing 1,2,3 in the place of 'x' is called "**Substitution**".

Let us examine the values of LHS and RHS by substituting values for the variable 'x' in $2x+5 = 27$

Substituting value (x)	Value of LHS (2x+5)	Value of RHS (27)	Whether LHS and RHS are equal
1	$2 \times 1 + 5 = 7$	27	Not equal
2	$2 \times 2 + 5 = 9$	27	Not equal
3	$2 \times 3 + 5 = 11$	27	Not equal
4	$2 \times 4 + 5 = 13$	27	Not equal
5	$2 \times 5 + 5 = 15$	27	Not equal
6	$2 \times 6 + 5 = 17$	27	Not equal
7	$2 \times 7 + 5 = 19$	27	Not equal
8	$2 \times 8 + 5 = 21$	27	Not equal
9	$2 \times 9 + 5 = 23$	27	Not equal
10	$2 \times 10 + 5 = 25$	27	Not equal
11	$2 \times 11 + 5 = 27$	27	Equal
12	$2 \times 12 + 5 = 29$	27	Not equal

From the table it is obvious that when 'x = 11' both LHS and RHS are equal. Therefore $x = 11$ is called the solution of equation $2x + 5 = 27$.

Solution of an equation is the value of the variable for which LHS and RHS are equal. The solution is also called as root of the equation.

In mathematics, Algebra is a powerful tool for solving puzzles, riddles and problems in our daily life.

Example: Consider the equation $3m = 15$

The following table shows for different values of 'm', the value of LHS and the comparison with the RHS.

Substituting value (m)	Value of LHS (3m)	Value of RHS (15)	Whether LHS and RHS are equal
1	$3 \times 1 = 3$	15	Not equal
2	$3 \times 2 = 6$	15	Not equal
3	$3 \times 3 = 9$	15	Not equal
4	$3 \times 4 = 12$	15	Not equal
5	$3 \times 5 = 15$	15	Equal
6	$3 \times 6 = 18$	15	Not equal

From the table we find that for $m=5$ both LHS and RHS are equal. Therefore $m = 5$ is the solution of the equation.

The method we followed in the above is called Trial and Error Method.



DO THIS

Find the solution of the equation ' $x - 4 = 2$ ' by Trial and Error method.



EXERCISE - 9.3

- State which of the following are equations.

(i) $x - 3 = 7$	(ii) $l + 5 > 9$	(iii) $p - 4 < 10$
(iv) $5 + m = -6$	(v) $2s - 2 = 12$	(vi) $3x + 5 > 13$
(vii) $3x < 15$	(viii) $2x - 5 = 3$	(ix) $7y + 1 < 22$
(x) $-3z + 6 = 12$	(xi) $2x - 3y = 3$	(xii) $z = 4$
- Write LHS and RHS of the following equations.

(i) $x - 5 = 6$	(ii) $4y = 12$	(iii) $2z + 3 = 7$
(iv) $3p = 24$	(v) $4 = x - 2$	(vi) $2a - 3 = -5$
- Solve the following equation by Trial & Error Method.

(i) $x + 3 = 5$	(ii) $y - 2 = 7$	(iii) $a - 2 = 6$
(iv) $5y = 15$	(v) $6n = 30$	(vi) $3z = 27$



WHAT WE HAVE DISCUSSED?

- We looked at the patterns arising from making of many identical letters or shapes using match sticks. We learnt to write general relation between the number of matchsticks required for making a number of identical shapes. Since the number of times the shape is repeated is a variable, we denote it by an alphabet in writing the rule.
- A variable takes different values. Its value is not fixed.
- We may use any letter $a, b, m, n, p, q, x, y, z$ etc., to represent a variable.
- A variable allows us to express relations in any practical situation.
- Variables are numbers, although their value is not fixed. We can do operations on them just as in the case of fixed numbers.
- We can form expressions with variables using different operations. Some examples are $2m, 3s+1, 8p, x/3$ etc.
- Variables allow us to express many common rules of geometry and arithmetic in a general way.
- An equation is a condition on a variable. Such a condition limits the values the variable can have.
- An equation has two sides, L.H.S. and R.H.S., on both sides of equality sign.
- Solution of an equation is the value of the variable for which LHS and RHS are equal.
- To get the solution of an equation, one of the methods used is the Trial and Error method.





10.1 INTRODUCTION

We studied about different shapes in chapter "Basic Geometrical Ideas". When we talk about plane figures, we think of regions covered by them and their boundaries. We need some measures to compare their sizes. Let us look into this now.

10.2 PERIMETER

Think of the following situations:

1. A boy is running around a circular path as shown in the figure. He starts running from point A and stops at A. Then the distance covered by the boy is the perimeter of the circular path.



2. A man wants to fence his field with wire. To find the length of wire needed he should measure the sides of the field.

Sum of the sides will give the perimeter of the field. The length of the boundary of a closed figure is called its perimeter. We use perimeter in many situations of our daily life.



TRY THESE

Give five examples of situations where you need to know the perimeter.

We can look at perimeter in another way.

Look at the figures given below:

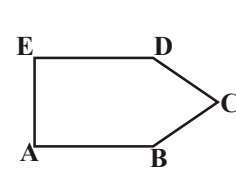
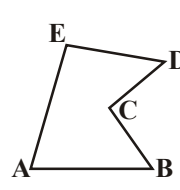
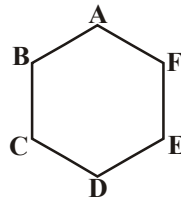
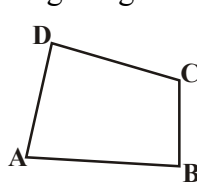
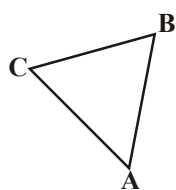

Take a wire or a string. Break the string into pieces of appropriate lengths, start placing the string pieces along the sides of the figures. When all the sides are covered, we can put the string together and measure its length. The length of the string is equal to the distance in going around the shape once. This length is known as the perimeter of the closed figure. It is the length of the wire to form the figures.

We can say that perimeter is the distance covered along the boundary forming a closed figure when you go around the figure once.



DO THIS

What would be the perimeter of these shapes?

Fill in the blanks given and in each case start from the point A.

i) Perimeter = $AB + \dots + \dots + \dots$
 = $\dots + \dots + \dots + \dots$
 = \dots m

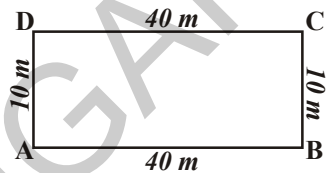

ii) Perimeter = $AB + \dots + \dots$
 + $\dots + \dots + \dots$
 = $\dots + \dots + \dots$
 + $\dots + \dots + \dots$
 = \dots m

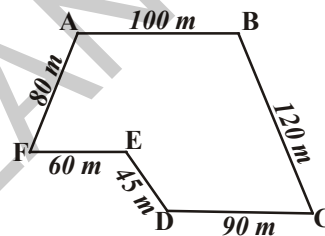

We see that to find the perimeter of a closed figure made up entirely of line segments we find the sum of the lengths of all the sides.

Example-1. Ritu went to a park 130 m long and 90 m wide. She took one complete round of it. What distance did she cover?

Solution: Total distance covered by Ritu = Perimeter of the park ABCD
 = $AB + BC + CD + DA$
 = $130 \text{ m} + 90 \text{ m} + 130 \text{ m} + 90 \text{ m} = 440 \text{ m}$

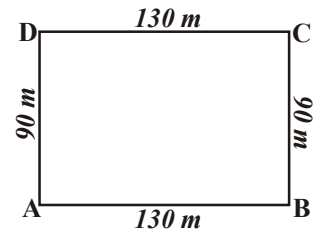

Example-2. Find the perimeter of given shape.

Solution: $IJ = DC = 3 \text{ m}$ $EF = HG = 2 \text{ m}$
 $AB = LK = 4 \text{ m}$ $FG = KJ = CB = 1 \text{ m}$
 $AL = BC + DE + FG + HI + JK$
 = $1 \text{ m} + 2 \text{ m} + 1 \text{ m} + 2 \text{ m} + 1 \text{ m}$
 = 7 m

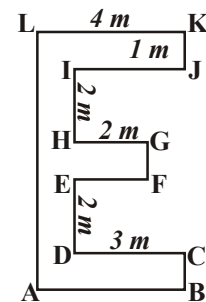

Perimeter = $AB + BC + CD + DE + EF + FG + GH + HI + IJ + JK + KL + LA$
 = $4 \text{ m} + 1 \text{ m} + 3 \text{ m} + 2 \text{ m} + 2 \text{ m} + 1 \text{ m}$
 + $2 \text{ m} + 2 \text{ m} + 3 \text{ m} + 1 \text{ m} + 4 \text{ m} + 7 \text{ m} = 32 \text{ m}$



TRY THESE

1. A table with sides equal to 30 cm, 15 cm, 30 cm and 15 cm respectively. Find its perimeter.
2. Measure the length of the sides of your text book cover. What is the perimeter?
3. Around a rectangular park of sides 100 meter and 70 meters a wire has to be put. The cost of the wire is ₹ 20 per meter. What is the total cost of the wire?

10.2.1 Perimeter of a Rectangle

Let us consider a rectangle ABCD whose length and breadth are 15 cm and 10 cm respectively. What will be its perimeter?

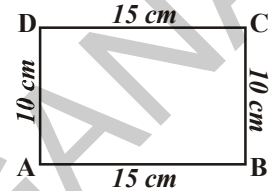

$$\begin{aligned}
 \text{Perimeter of the rectangle} &= \text{Sum of the lengths of its four sides} \\
 &= AB + BC + CD + DA \\
 &= AB + BC + AB + BC \\
 &= 2 \times AB + 2 \times BC \\
 &= 2 \times (AB + BC) \\
 &= 2 \times (15 \text{ cm} + 10 \text{ cm}) \\
 &= 2 \times 25 \text{ cm} \\
 &= 50 \text{ cm}
 \end{aligned}$$

We know that the opposite sides of a rectangle are equal
so $AB = CD$, $AD = BC$

We see that

perimeter of a rectangle = length + breadth + length + breadth

i.e. perimeter of a rectangle = $2 \times (\text{length} + \text{breadth})$

Perimeter of a rectangle $P = 2(l + b)$

where l = length, b = breadth and P = perimeter.

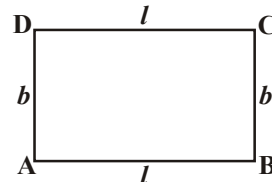

TRY THESE

Find the perimeter of the following rectangles.

Length of rectangle	Breadth of rectangle	Perimeter by adding all the sides	Perimeter by the formula $2 \times (\text{Length} + \text{Breadth})$
20 cm	15 cm	$= 20 \text{ cm} + 15 \text{ cm}$ $+ 20 \text{ cm} + 15 \text{ cm}$ $= 70 \text{ cm}$	$= 2 \times (20 + 15)$ $= 2 \times (35)$ $= 70 \text{ cm}$
0.7 m	0.3 m		
22 cm	18 cm		
12.5 cm	7.5 cm		

Example-3. Find the perimeter of a rectangular field which is 36 m long and 24 m wide.

Solution: Length of the field (l) = 36 m
Breadth of the field (b) = 24 m
Therefore, perimeter of the field (P) = $2(l + b)$
= $2(36 + 24)$ m
= 2×60 m
= 120 m

Example-4. Find the breadth of a rectangle whose perimeter is 76 cm and length is 26 cm

Solution: Perimeter of the rectangle (P) = 76 cm
Length of the rectangle (l) = 26 cm
Perimeter of the rectangle = $2(\text{length} + \text{breadth})$
So, 76 = $2(26 + \text{breadth})$
26 + breadth = $76 \div 2 = 38$
Breadth = $38 - 26 = 12$ cm
Hence, breadth of the rectangle = 12 cm

Example-5. The length and breadth of a rectangular field are 22.5 m and 14.5 m respectively. Find the cost of fencing its four sides at the rate of ₹ 6 per meter.

Solution: Length of the field (l) = 22.5 m
Breadth of the field (b) = 14.5 m
Perimeter of the field (P) = $2(l + b)$
= $2(22.5 + 14.5)$ m
= 2×37 m
= 74 m

Thus, cost of fencing at ₹ 6 per meter.
= ₹ (6×74)
= ₹ 444

Example-6. How many different rectangles with integral measurements can be drawn with perimeter as 32 cm?

Solution: Perimeter = 32 cm
Half of the perimeter = $\frac{32}{2}$ cm = 16 cm

Now, we have to find the number of rectangles that can be drawn, the sum of whose length and breadth is 16 cm. Keeping in mind that the sides are positive integers in cm,

all possible pairs of length and breadth are

(15, 1) (14, 2) (13, 3) (12, 4) (11, 5) (10, 6) (9, 7) (8, 8)

Hence, eight rectangles can be drawn.

Do This

1. A square picture frame has sides of 0.75 meters. If the cost of a coloured paper is ₹ 20 per meter, what is the cost of putting coloured paper around the frame?
2. There is a string of length 44 cm. How many different rectangles with positive integers as length and breadth can be made with this string?
3. If I have a string 41 cm long can I make a rectangle with sides as positive integers using the string completely? Give reasons.

10.2.2 Perimeter of Regular shapes

Polygons are the simple closed plane figures bounded by line segments. A polygon is called a regular polygon, if all its sides are of equal length and all angles are of equal measure.

Equilateral triangle is a regular three sided polygon.

Square is a regular four sided polygon. Now let us try to find the perimeter of a square.

Since the sides of a square are equal.

$$\begin{aligned}\text{So, perimeter} &= a + a + a + a \\ &= 4 \times a = 4a\end{aligned}$$

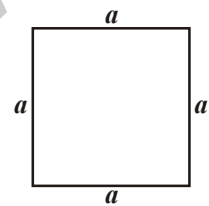

Perimeter of a square = 4 × length of any side.

Now, look at equilateral triangle with each side equal to 4 cm Can we find its perimeter?

Perimeter of this equilateral triangle

$$\begin{aligned}&= (4 + 4 + 4) \text{ cm} \\ &= 3 \times 4 \text{ cm} = 12 \text{ cm}\end{aligned}$$

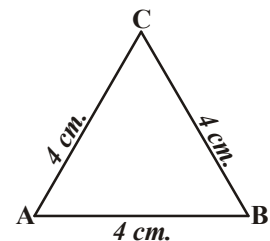

In general if 'a' represents the side of an equilateral triangle then the perimeter is $3 \times a = 3a$.

Perimeter of an equilateral triangle = 3 × length of any side



TRY THESE

1. Find the perimeter of the following squares. Figures are drawn on 1 cm grids.

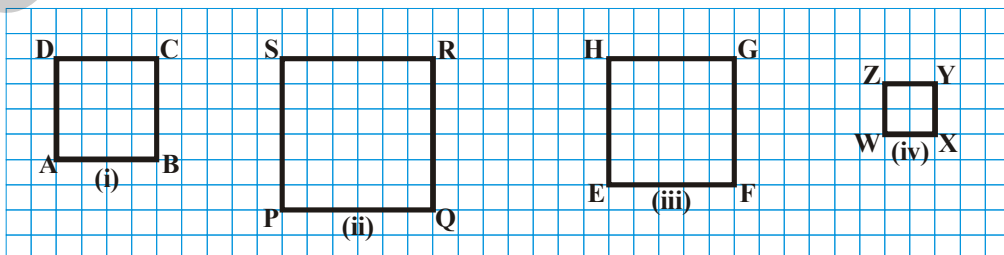

2. Find various objects from your surroundings which have regular shapes and their perimeters.

Regular Polygon

Geometrical shapes that have all the sides equal and all angles equal are called regular polygon. Square and equilateral triangles are examples of regular polygon. There can be 5-sided, 6-sided or more sided regular figures. Their perimeters are the sum of their sides.

We can thus see that in general

perimeter of a regular 5-sided polygon (pentagon) = $5 \times$ length of any side

perimeter of a regular 6-sided polygon (Hexagon) = $6 \times$ length of any side

perimeter of a regular 8-sided polygon (Octagon) = $8 \times$ length of any side



DO THIS

Find the perimeter of a regular pentagon of side 8 cm

Example-7. Find the cost of fencing a square park of side 250 m at the rate of ₹ 20 per meter.

Solution: Perimeter of the square park = $4 \times$ length of a side

$$= 4 \times 250 = 1000 \text{ m}$$

Cost of fencing the park = ₹ 20 per meter

Thus, total cost of fencing the park = ₹ $1000 \times 20 = ₹ 20,000$

Example-8. Find the side of the equilateral triangle whose perimeter is 54 cm

Solution: Perimeter of an equilateral triangle = $3 \times$ length of a side

$$\text{Thus, length of a side} = \frac{\text{Perimeter}}{3} = \frac{54}{3} = 18 \text{ cm}$$

Example-9. A piece of wire is 24 cm. long. What will be the length of each side, if the wire is used to form.

- (i) an equilateral triangle (ii) a square (iii) a regular hexagon

Solution:

(i) Perimeter of equilateral triangle = $3 \times$ length of a side

$$\text{Length of its side} = \frac{24}{3} = 8 \text{ cm}$$

(ii) Perimeter of square = $4 \times$ length of a side

$$\text{Length of its side} = \frac{24}{4} = 6 \text{ cm}$$

(iii) Perimeter of regular hexagon = $6 \times$ length of a side

$$\text{Length of its side} = \frac{24}{6} = 4 \text{ cm}$$



EXERCISE - 10.1

1. Find the perimeter of each of the following shapes:

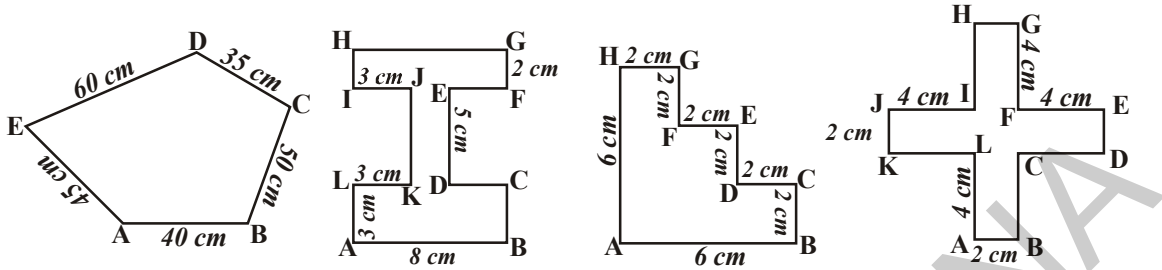

2. Find the perimeter of each of the following figures.

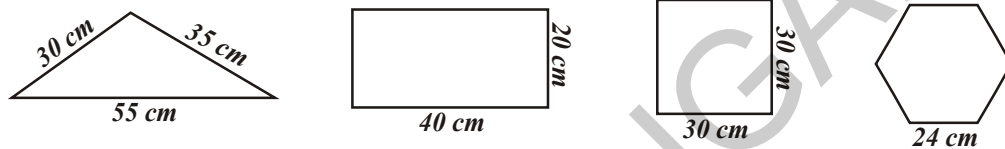

What would be the cost of putting a wire around each of these shapes given that 1 cm wire costs ₹ 15?

3. How many different rectangles can you make with a 24 cm long string with integral sides and what are the sides of those rectangles in cm?
4. A flower bed is in the shape of a square with a side 3.5 m. Each side is to be fenced with 4 rows of ropes. Find the cost of rope required at ₹ 15 per meter.
5. A piece of wire is 60 cm long. What will be the length of each side if the string is used to form:
- an equilateral triangle
 - a square.
 - a regular hexagon
 - a regular pentagon.
6. Bunty and Bubby go for jogging every morning. Bunty goes around a square park of side 80 m and Bubby goes around a rectangular park with length 90 m and breadth 60 m. If they both take 3 rounds, who covers more distance and by how much?
7. The length of a rectangle is twice of its breadth. If its perimeter is 48 cm, find the dimensions of the rectangle?
8. Two sides of a triangle are 12 cm and 14 cm. The perimeter of the triangle is 36 cm. What is the length of third side?
9. Find the perimeter of each of the following shapes:
- A triangle of sides 3 cm, 4 cm and 5 cm
 - An equilateral triangle of side 9 cm
 - An isosceles triangle with equal sides 8 cm each and third side of 6 cm

10.3 AREA

Look at the closed figures given below. All of them occupy some region of a flat surface. In the pairs of figures, Can you find which one occupies more region? Mark a tick (✓) on them:

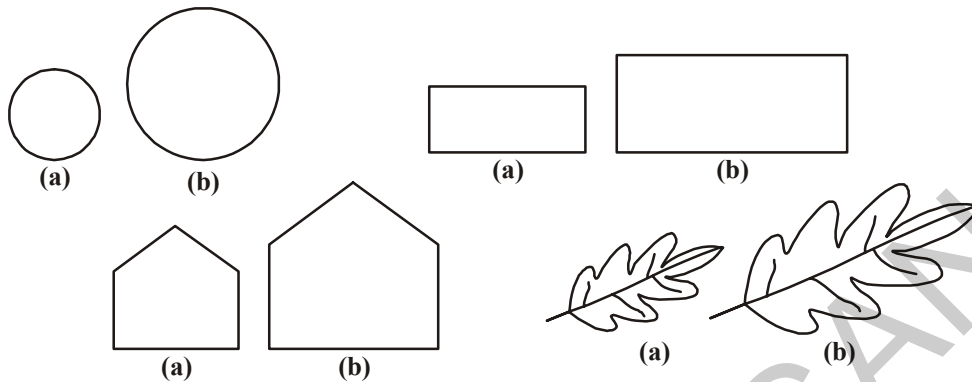

The amount of surface enclosed by a closed figure is called its area.

In the above pair of figures you can tell, which has more area but is that always possible?

Now look at the adjacent figures.

Which has more area? It is not easy to say. Let us use a graph paper to help.

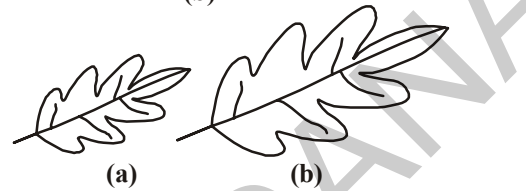

Take the shape (ii) and place it on a squared paper or graph paper where every square measures $1\text{ cm} \times 1\text{ cm}$. Make an outline of the figure.

Look at the squares covered by the figure. Some of them are completely covered, some half, some less than half and some more than half. The completely covered squares are shown shaded in picture (iii).

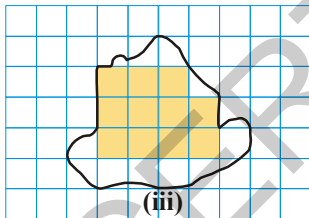

We know that the area is the number of centimeter squares that are needed to cover the shape.

But as we can see there is a small problem. The squares do not always fit exactly into the area you measure. Some fit completely, some are marginally covered and some are largely included in the shape. We get over this difficulty by adopting some rules:

- Ignore portions of the area that are less than half a square.
- If more than half of a square is in the region, just count it as one square.
- If exactly half the square is covered, take its area as $\frac{1}{2}$ square unit.
- The area of one full square is taken as 1 square unit. If it is a centimeter square sheet, then the area of one full square will be a square centimeter.

Such a rules give a fair estimate of the desired area as the ignored ones balance out the incomplete ones included.

Now count the squares in the figure (iii) and fill in the information in the table.

	Covered Area	No. of squares	Estimated Area (sq units)
(i)	Fully-filled squares	11	11
(ii)	Half-filled squares	2	$2 \times \frac{1}{2}$
(iii)	More than half-filled squares	8	8
(iv)	Less than half filled squares	3	0

$$\text{Total area} = 11 + 2 \times \frac{1}{2} + 8 = 20 \text{ sq units}$$

We can thus compare any two shapes by counting the squares covered by their outline on the graph or square paper grid.



TRY THIS

Find the areas of the following figures by counting squares.

Area of each square is 1 sq.cm.

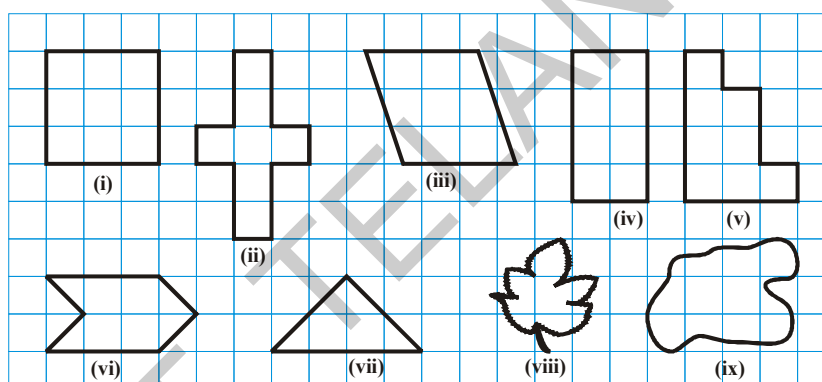

DO THIS

- Trace shapes of leaves, flower petals and other such objects on the graph paper and find their area approximately.
- Draw any line diagram on a graph sheet. Count the squares and use them to estimate the area of the region.

10.3.1 Area of the rectangle

With the help of the graph paper, can we tell the area of a rectangle whose length is 7 cm and breadth is 4 cm?

Draw the rectangle on a graph paper having $1 \text{ cm} \times 1 \text{ cm}$ squares. The rectangle covers 28 squares completely. \therefore The area of the rectangle = 28 sq cm

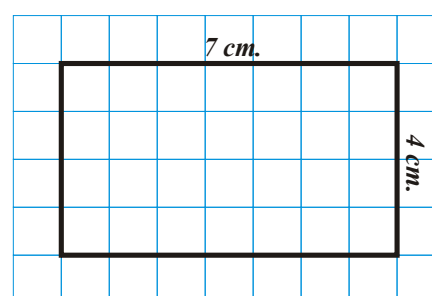

We can see that there are 7 squares in each row and there are 4 rows. This can be written as $7 \times 4 = 28$.

Here, area of the rectangle is 28, length of the rectangle is 7 and breadth of the rectangle is 4.

With the following measurements draw rectangles on a graph paper and find their area by counting the completely covered squares. Also find the product of length and breadth. What can you think from the results obtained?

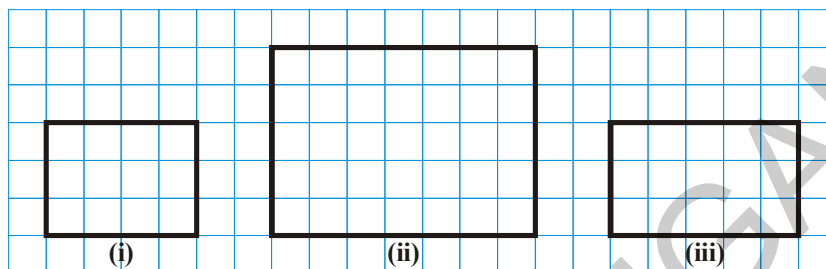

S.No.	Length	Breadth	Area (Total no. of squares)	length \times breadth
1.	4	3	12	$4 \times 3 = 12$ sq. cm.
2.				
3.				

Thus from the above discussion and the results we can establish that

$$\text{Area of rectangle} = \text{length} \times \text{breadth}$$

Without using the graph paper, we can now able to find the area of a rectangle. For example if the length of a rectangle is 6 cm and breadth is 4 cm then the

$$\text{Area of the rectangle} = \text{Length} \times \text{breadth} = 6 \times 4 = 24 \text{ sq. cm.}$$



TRY THESE

- Draw two different rectangles having the same perimeter. Compare their areas. Are they same? Can you draw two different squares having the same perimeter.



DO THIS

- Find the area of:
 - The floor of your classroom.
 - A door in your house
 - The black board in your classroom.

10.3.2 Area of the Square

Let us consider a square of side 4 cm. If we place it on a centimeter graph paper then we observe that it covers 16 squares.

So the area of the square = $4 \times 4 = 16$ sq. cm.

There are four squares in each row and there are four rows. So the area is $4 \times 4 = 16$ sq cm. We know that a square is just like a rectangle with the special condition that its length is equal to the breadth.

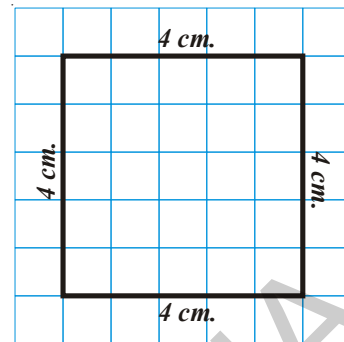

TRY THESE

The length of one side of few squares are given. Find their areas using graph papers also find side \times side. What do you notice from the results obtained?

i) 4 cm

ii) 6 cm

iii) 2 cm

iv) 8 cm

From the above discussion

$$\begin{aligned}\text{Area of the square} &= \text{Side} \times \text{Side} \\ &= (\text{Side})^2\end{aligned}$$

Example-10. How many tiles with dimensions 12 cm and 5 cm will be needed to fit a region whose length and breadth are 144 cm and 100 cm respectively.

Solution:

Length of the region	= 144 cm
Breadth of the region	= 100 cm
Area of the region	= $144 \text{ cm} \times 100 \text{ cm}$
	= 14,400 sq cm
Length of 1 tile	= 12 cm
Breadth of 1 tile	= 5 cm
Area of 1 tile	= $12 \text{ cm} \times 5 \text{ cm}$
	= 60 sq cm

$$\begin{aligned}\therefore \text{Number of tiles required} &= \frac{\text{area of region}}{\text{area of 1 tile}} = \frac{14400}{60} \\ &= 240 \text{ tiles}\end{aligned}$$

Example-11. The perimeters of a rectangle and a square are same. If the length and breadth of the rectangle are 35 cm and 25 cm respectively. Find which figure has greater area and by how much.

Solution: Perimeter of the rectangle = 2 (length + breadth)
 = 2 (35 + 25) = 2 × 60 = 120 cm

∴ So perimeter of the square = 120 cm

Now side of the square = $\frac{120}{4} = 30$ cm

∴ Area of the square = (side)² = (30)² = 900 sq cm

Area of the rectangle = length × breadth
 = 35 × 25 = 875 sq cm

Thus the square has greater area by (900 - 875) sq cm = 25 sq cm

Example-12. Find the area of a rectangle whose length is 4 m and breadth is 68 cm.

Calculate the area in sq cm.

Solution : Length of the rectangle = 4 m = 400 cm
 Breadth of the rectangle = 68 cm
 Area of the rectangle = length × breadth
 = 400 × 68
 = 27,200 sq cm

Example-13. The area of a rectangular garden which has 40 meter length is 1120 sq m. Find the width of the garden?

Solution: Area of the rectangle = 1,120 square meters
 Length of the rectangle = 40 meters
 Area of the rectangle = length × width

$$\text{So width} = \frac{\text{Area}}{\text{Length}} = \frac{1120}{40} = 28 \text{ meters}$$

Example-14. Five square flower beds each of side 1m are dug on a piece of land 5 m long and 4 m wide. What is the area of the remaining part of the land?

Solution : Area of the piece of land = length × breadth
 = 5 × 4 sq meters
 = 20 sq meters

Area of each square flower bed = 1 × 1 = 1 sq. m.
 So area of 5 square flower beds = 5 sq meters

Area of Land remaining = 20 - 5 = 15 sq meters



EXERCISE - 10.2

- Find the area of the rectangles with the given sides:
 - 50 cm and 20 cm
 - 65 m and 45 m
 - 25 cm and 16 cm
 - 7 km and 19 km
- Find the area of squares with the given sides:
 - 26 m
 - 17 m
 - 52 cm
 - 8 cm
- The area of rectangular frame is 1,125 sq cm. If its width is 25 cm, what is its length?
- The length of a rectangular field is 60 m and the breadth is half of its length. Find the area of the field.
- A square sheet of paper has a perimeter of 40 cm. What is the length of its side? Also find the area of the square sheet?
- The length and breadth of a room are 6 m and 4 m respectively. How many square meters of carpet is required to completely cover the floor of the room? If the carpet costs ₹240 a square meter, what will be the total cost of the carpet for completely covering the floor?
- Two fields have the same perimeter. One is a square of side 72 m and another is a rectangle of length 80 m. Which field has the greater area and by how much?
- The area of a square is 49 sq cm. A rectangle has the same perimeter as the square. If the length of the rectangle is 9.3 cm, what is its breadth? Also find which has greater area?
- Rahul owns a rectangular field of length 400 m and breadth 200 m. His friend Ramu owns a square field of length 300 m. Find the cost of fencing the two fields at ₹150 per meter. If one tree can be planted in an area of 10 sq m, who can plant more trees in his field? How many more trees can he plant?
- The length of a rectangular floor is 20 m more than its breadth. If the perimeter of the floor is 280 m, what is its length?
- A rectangular plot of land is 240 m by 200 m. The cost of fencing per meter is ₹ 30. What is the cost of fencing the entire field?
- The side of a square field is 120 meters. The cost of preparing a grass lawn is ₹ 35 per square meter. How much will it cost, if the entire field is converted into a lawn?

13. What will happen to the area of rectangle, if
- Its length and breadth are doubled?
 - Its length is doubled and breadth is tripled?
14. What will happen to the area of a square if its side is:
- doubled
 - halved



WHAT HAVE WE DISCUSSED?

- Perimeter is the distance covered along the boundary forming a closed figure when you go round the figure once.
- Perimeter of a rectangle = $2 \times (\text{length} + \text{breadth})$
 - Perimeter of a square = $4 \times \text{length of its side}$
 - Perimeter of an equilateral triangle = $3 \times \text{length of any side}$
- Polygon in which all sides and angles are equal are called regular polygons.
 - The perimeter of a regular polygon is equal to the number of sides times the size of each side.
- The amount of surface enclosed by a closed figure is called its area.
- To calculate the area of a figure using a graph paper, the following conventions are adopted:
 - Ignore portions of the area that are less than half a square.
 - If more than half a square is in the region. count it as one square.
 - If exactly half the square is covered, take its area as $\frac{1}{2}$ sq units.
- Area of a rectangle = length \times breadth
 - Area of square = side \times side
 - The area of a square is more than the area of any other rectangle having the same perimeter.





11.1 INTRODUCTION

In our day to day life, we compare quantities in different ways. In the market, we compare which vegetables look fresh, which are expensive, which are reasonably priced etc. Let us consider some examples.

Every day Satya and Madhukar drink milk before going to school. Satya adds 2 spoons of sugar to 1 cup of milk. Madhukar adds 1 spoon of sugar in same sized cup of milk.



Which milk will be sweeter? Can we say without tasting the milk?

Sharada has 3 spoons of sugar in 2 cups of milk. How do we compare the sweetness of milk in the three cases?

Consider the following situation.

Siri has 8 note books and Ravi has 16 note books.

To compare the books, Ravi compared them by finding their difference. And Siri compared them by division. One quantity is how much more or how much less than the other quantity is comparison by subtraction. And one quantity is how many times more or less than the other is comparison by division.



Give 3 instances where we compare quantities by subtraction and by division.

If we wish to compare the length of an ant and a grasshopper. The difference in length does not express the comparison. The grasshopper's length, which is approximately 4 cm to 5 cm, is too long in comparison to an ant's length which is just a few mm. The difference in length would be around 4cm only. That by itself does not appear to be a big difference. Comparison will be better if we try to find out how many ants can be placed one behind the other to match the length of the grasshopper. So we may say that 15 to 20 ants together have the same length of a grasshopper.

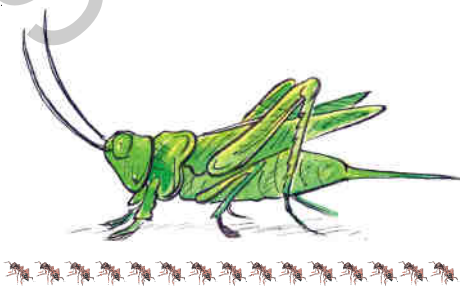

Consider another example.

The cost of a car is ₹ 2,50,000 and that of a motorbike is ₹ 50,000. If we compare the cost by taking the difference between the costs, the difference is ₹ 2,00,000. This does not

help us to understand the extent of difference. If we compare by division; then $\frac{2,50,000}{50,000} = \frac{5}{1}$

which tells us that for cost of every car we can buy 5 motorcycles.

Thus, in certain situations, comparison by division makes better sense than comparison by taking the difference.

Let us consider one more example.

Latha is 3 years old and Kareem is 18 years old. We can say that Kareem is 15 years older than Latha. Compare this with Rahim being 65 years old and Reshma 50 years. In both the cases the difference in the ages is 15 years. It is obvious however, the difference in Latha and Kareem is of a different kind. It is much better to say that Kareem is six times older than Latha.

This type of the comparison where we compare things by division is called ratio. In this chapter we will learn about ratio in detail.

Another example where we use such comparison is in making maps.

Look at the map:

The places on a map are very close by as compared to the actual distance between them. The scale of map tells us that the comparison between the actual distance and the distance shown in the map. For example, a map of a street or a market, the scale says 1 cm = 100 m, then we know that the distance on the map is ten thousandth of the actual distance. In other words actual distance is 10,000 times the distance on the map.

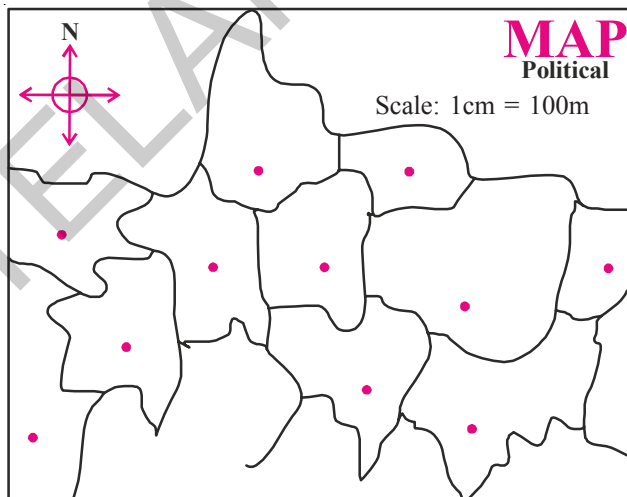

If we compare the distance on the map to the actual distance represented we would say that 5 cm represents 500 meters. Comparison by subtraction would tell us that the actual distance is 499 meters 95 cm more than the distance on the map. Compared to the statement that the actual distance is 10,000 times the distance on the map, this statement does not convey much.

In the first example ratio of Siri's books to Ravi's books is $\frac{16}{8} = \frac{2}{1} = 2 : 1$

We read it as 2 is to 1.

If we change the comparison order and ask for the ratio of Ravi's books to Siri's books, the answer will be $\frac{8}{16} = \frac{1}{2} = 1 : 2$



TRY THESE

Observe the example and fill in the blanks.



S.No.	No. of items (Basket 1)	No. of items (Basket 2)	Comparing statement	Ratio	Comparison by changing the order	Ratio
1	2 apples	6 apples	Apples in the first basket are one-third of the apples in the second basket.	1 : 3	Apples in the second basket are 3 times the apples in the first basket.	3 : 1
2	500 g of Copper	1000 g of Iron				
3	Cost of T-Shirt ₹ 200	Cost of a Coat ₹ 1000				

11.2 Comparing quantities with different units

The height of a tree is 13 m and its picture in the book is 26 cm long. Can we say that the height of the tree in the picture is twice that of the actual tree? Obviously not, as we know actual tree is taller than the tree shown in the picture.

Height of the tree is 13 m i.e. $13 \times 100 = 1300$ cm and the height of tree in the picture is just 26 cm

$$\text{Now the ratio between two heights} = \frac{1300}{26} = 50 : 1$$

So we can say that the tree's actual height is 50 times than that of the picture in the book.



When we compare two quantities, they must be in the same units.

In general the ratio of two quantities **a** and **b** is written as **a : b** and we read it as **a is to b**

The two quantities **a** and **b** are called terms of the ratio. First quantity 'a' is called **first term** or **antecedent** and second quantity 'b' is called **second term** or **consequent**.

Example-1. Rafi has 16 red marbles and 4 blue marbles. Find the ratio of red marbles to blue marbles Rafi has?











Solution: Red marbles : Blue marbles = 16 : 4
= 4 : 1

Number of red marbles are 4 times than that of blue marbles.



EXERCISE - 11.1

1. Complete the following table.

S. No.	First quantity	Second quantity	Ratio
i)			3 : 5
ii)			
iii)			
iv)			
v)			

2. Compare:

- (i) Number of blue coloured squares is _____ times of the number of red colour squares.
- (ii) Number of red coloured squares is _____ times of the number of blue coloured squares.
- (iii) Find the ratio of number of blue squares to the number of red squares.



3. Solve the following:

- (i) A milk man adds 250 ml of water to 1 litre of milk. Find the ratio of water to milk.
- (ii) Satya's mother bought 4 kg pulses and 50 g chilli powder. Find the ratio of weights of chilli powder to pulses. What is the ratio of weights of the pulses to chilli powder?
- (iii) Rani takes 30 minutes to reach school from home. Ismail takes $\frac{1}{2}$ an hour to cover the same distance. Find the ratio of time taken by Rani to the time taken by Ismail.

11.3 Ratio in different situation

Sloka is in class VI. She has ₹50 with her. Mahesh is also in the same class. He has ₹100 with him. Both of them decided to save their amounts in 'Sanchayika', a savings programme in their school. After depositing their amounts, they came to know that total money saved by their class students is ₹ 2000. They want to compare their amount to the total amount saved.

The ratio of savings of Sloka to savings of Mahesh = 50:100

The ratio of savings of Sloka to the total money saved = 50:2000



ACTIVITY

Take a square ruled paper. Throw a dice and note the number on the dice. Fill as many squares as the number noted with your favorite colour. Ask your friend to throw a dice and colour as many squares as the number on the dice with some other colour.

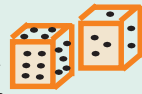

1. Find the ratio of number of squares coloured by you to the number of squares coloured by your friend?
2. Find the ratio of number of squares coloured by you to the total number of squares coloured?
3. Find the ratio of number of squares coloured by your friend to the total number of squares coloured?
4. Can you find any other ratios in this activity? Think and discuss with your friend.

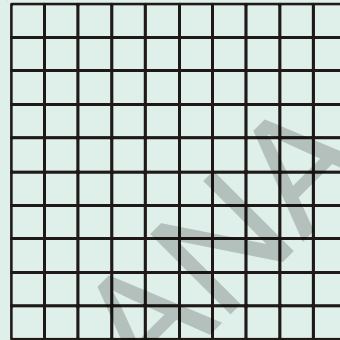

TRY THESE

In the given figure, find the ratio of

- (i) Shaded parts to unshaded parts
- (ii) Shaded parts to total parts
- (iii) Unshaded parts to total parts

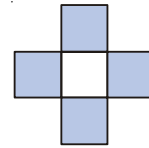

11.4 Same ratio in different situations

Consider the following:

- Length of a room is 30 m and its breadth is 20 m. So, the ratio of length of the room to the breadth of the room = $\frac{30}{20} = \frac{3}{2}$ is same as 3 : 2
- There are 24 girls and 16 boys going for a picnic. Ratio of the number of girls to the number of boys = $\frac{24}{16} = \frac{3}{2}$ is the same as 3 : 2

The ratio in both the examples is 3 : 2.

- Note, the ratio 30 : 20 and 24 : 16, in lowest form are same as 3 : 2. These are **equivalent ratios**.

Can you think of some more examples having the ratio 3 : 2?

It is fun to write situations that give rise to a certain ratio. For example, write situations that give the ratio 2 : 3. We have given two examples, you write 3 more.

- Ratio of the breadth of a table to the length of the table is 2 : 3.
- Sheena has 2 marbles and her friend Shabnam has 3 marbles. The ratio of marbles

Example-2. In a mathematics class there are 16 boys and 20 girls. Find the ratio of number of boys to the number of girls and express it in the simplest form.

Solution: Ratio of number of boys to number of girls = 16: 20

$$= \frac{16}{20} = \frac{2 \times 2 \times 2 \times 2}{2 \times 2 \times 5} = \frac{4}{5}$$

The simplest form is 4 : 5

A ratio is said to be in the **simplest form** or in the **lowest terms** when it is written in terms of whole numbers with no common factors other than 1.

TRY THESE

1. Complete the following tables

Ratio	1:2	2:3	5:7		
1 time	1:2				
2 times		4:6			
3 times			15:21		
4 times				12:16	
5 times					20:25

Remember:
Ratio is comparison of quantities expressed in same units

2. Complete the following table.

S.No.	First quantity	Second quantity	Ratio	Simplified ratio
1.	20 paise	₹ 1		
2.	800 g	1 kg		
3.	1 hr	30 min		
4.	2 m	125 cm		
5.	3 min	45 sec		
6.	30 mm	1 cm		

Fill this first

1 rupee = paisa

1000 g = kg

1 hour = min

100 cm = m

1 minute = sec

10 mm = cm

3. In the following figures, express the ratio of shaded parts to unshaded parts in the simplest terms.

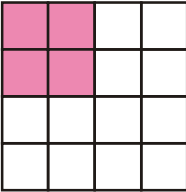

(i)

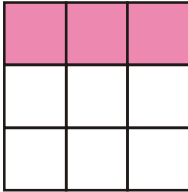

(ii)

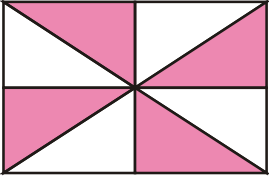

(iii)

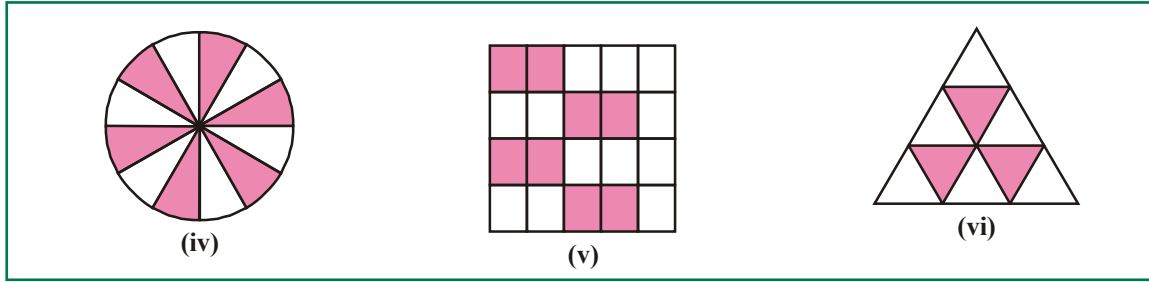

EXERCISE - 11.2

- Among the following, which ratios are in the simplest form? If not, convert them into the simplest form.
i) 2:3 ii) 16:20 iii) 5:6 iv) 20:60 v) 8:15 vi) 19:2
- A bag contains 20 kg of rice and another bag contains 60 kg of wheat. Find the ratio of the amount of rice to that of wheat? What is the ratio of rice to the total weight?
- There are 32 students in a class of which 12 are girls. Find:
 - The ratio of number of boys to number of girls
 - The ratio of number of boys to total number of students
 - The ratio of number of girls to total number of students.
- Draw a four sided closed figure and divide it in to some number of equal parts. Shade the figure with any colour so that the ratio of shaded parts to unshaded parts is 1: 3. Draw two more different figures and do the same.
- Imran bought 2 liters of oil and Vijay bought 500 ml of oil. Find the ratio of quantities of oil bought by Imran to oil bought by Vijay.
- Weight of Abraham is 20 kg and his father's weight is 60 kg. Find the ratio of weight of Abraham and his father. Express it in the simplest form.
- Ramu spent $\frac{2}{5}$ th of his money on a story book. Find the ratio of money spent to the money with him at the beginning.

11.5 Division of a given quantity in a given ratio

Example-3. On Snigdha's birthday, her father brought a flower bouquet that contain 18 flowers in all. If the ratio of red flowers to yellow is 1 : 2. Find their number.

Solution: Ratio of red flowers to yellow flowers = 1 : 2

$$\text{Total parts} = 1 + 2 = 3 \text{ parts}$$

$$\text{Total number of flowers} = 18 \text{ flowers}$$

$$3 \text{ parts} = 18 \text{ flowers}$$

$$\text{Each part} = \frac{18}{3} = 6 \text{ flowers}$$

$$\text{Red flowers} = 1 \text{ part} = 1 \times 6 \text{ flowers} = 6 \text{ flowers}$$

$$\text{Yellow flowers} = 2 \text{ parts} = 2 \times 6 \text{ flowers} = 12 \text{ flowers.}$$

Example-4. A goldsmith mixes gold and copper in the ratio 7:2 to prepare an ornament. If the ornament weighs 45 gms, find the weight of gold and copper in it.

Solution: Ratio of gold and copper = 7:2
 Sum of the ratio terms = $7+2=9$
 Weight of 9 parts = 45 gm
 Weight of each part = $45 \div 9 = 5$ gm
 Weight of gold = 7 parts $\times 5$ gm = 35 gm
 Weight of copper = 2 parts $\times 5$ gm = 10 gm

Example-5. Line segment AB is divided into five equal parts.



- i) In what ratio does X divide line segment AB?
- ii) If the length of the line segment AB is 15 cm, find the length of the line segments AX and XB.

Solution: i) X divides AB in the ratio 3:2
 ii) Total parts = $3 + 2 = 5$ parts
 Length of line segment AB = 15 cm
 Length of 5 parts = 15 cm
 Length of each part = $\frac{15}{5} = 3$ cm
 Length of line segment AX = 3 parts = 3×3 cm = 9 cm
 Length of line segment XB = 2 parts = 2×3 cm = 6 cm

TRY THESE

Make a pattern with squared tiles using black and white tiles in the ratio 2 : 5. There are many possible ways.

Example-6. Hari and Teja won a Lottery, which they agreed to share in the ratio of 5:3. If Teja received ₹150, how much did Hari receive? Also find the total amount.

Solution: Ratio of Hari's amount to Teja's amount is = 5 : 3
 Teja's share = 3 parts = ₹150
 $1 \text{ part} = \frac{150}{3} = ₹50$
 So, Hari's share = 5 parts = $₹50 \times 5 = ₹250$
 Hari will receive ₹250 and the total amount = $250 + 150 = ₹400$

EXERCISE - 11.3

1. A bag of 25 marbles is shared between Rahul and Kiran in the ratio 2: 3
 - i) How many marbles does Kiran receive?
 - ii) How many marbles does Rahul receive?
2. A point X on AB = 14 cm divides it in the ratio 3 : 4. Find the length of AX and XB.

- Geetha and Laxmi won ₹ 1050 in a game. They agreed to share the amount in the ratio of 3:4. How much does each person receive?
- Divide ₹ 3600 between Satya and Vishnu in the ratio of 3:5.
- Two numbers are in the ratio 5:6. If the sum of the numbers is 132, find the two numbers.
- Estimate the ratio in which X divides AB and then check your estimation by measuring it.

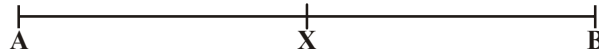

- The income and savings of an employee are in the ratio 11:2. If his expenditure is ₹5346, then find his income and savings.

11.6 PROPORTION

Observe the following figures. Do you find any changes in the shape?

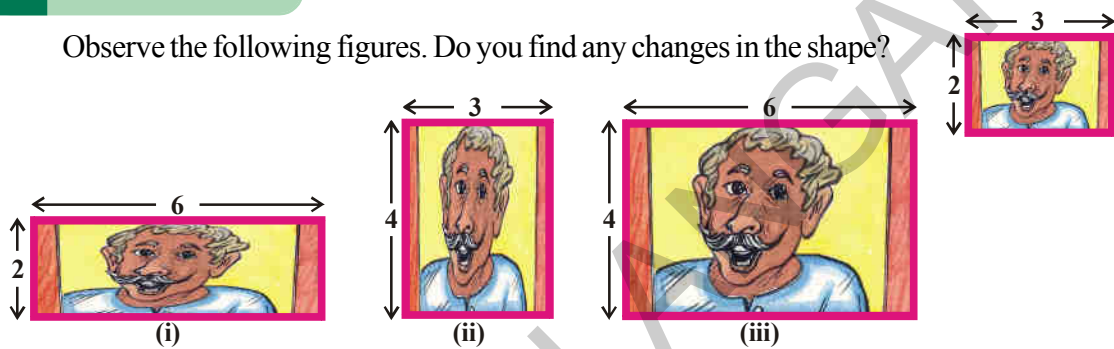

What difference do you find in the figures? The figures (i) and (ii) look different and their shapes have changed. Figure (iii) is enlarged but it does not look different. This is because there is a change in the size, but not in the shape.

Let us find the ratio of length and breadth in all the three cases

Ratio of length and breadth in the original picture = 3:2

Ratio of length and breadth in picture (i) = 6 : 2 i.e. simplest form is 3 : 1

Ratio of length and breadth in picture (ii) = 3 : 4 i.e. simplest form is 3 : 4

Ratio of length and breadth in picture (iii) = 6 : 4 i.e. simplest form is 3:2 which is as same as the ratio in the original picture. We can say picture (iii) is proportionate to the original picture and that's why their ratios are same. This equality of ratios is Proportion.

In general if the ratio of 'a' and 'b' is equal to the ratio of 'c' and 'd', we say that **a, b, c, d** are in proportion. This is represented as **a : b :: c : d**.

Consider another example.

Bhavika has 28 marbles and Vinila has 180 flowers. They want to share these among themselves. Bhavika gave 14 marbles to Vinila, and Vinila gave 90 flowers to Bhavika. But Vinila was not satisfied. She felt that she had given more flowers to Bhavika and the marbles given by Bhavika to her were much less.

What do you think? Is Vinila correct?

To solve this, both went to Vinila's mother Pooja.

Pooja explained that out of 28 marbles Bhavika gave 14 marbles to Vinila.

Therefore, ratio is $14 : 28 = 1 : 2$

And out of 180 flowers, Vinila had given 90 flowers to Bhavika.

Therefore, ratio is $90 : 180 = 1 : 2$.

Since both the ratios are the same, the distribution is fair. Do you agree with Pooja's version?

Example-7. Raju and Bharath add their money and bought 20 pencils. Raju contributed ₹12 and Bharath ₹18. They wanted to distribute the pencils between them.

- (i) Bharath said 10 pencils for each
- (ii) Raju said 12 pencils for Bharath and 8 pencils for him.

Who is correct? justify your answer.

Solution: Ratio of amounts given by Raju and Bharath = $12 : 18$
 $= 12 \div 6 : 18 \div 6$
 $= 2 : 3$

- (i) According to Bharath, Ratio of pencils = $10 : 10$
 $= 10 \div 10 : 10 \div 10$
 $= 1 : 1$

Equal distribution of pencils is not proportional to the amount contributed.

- (ii) According to Raju, Ratio of pencils = $8 : 12$
 $= 8 \div 4 : 12 \div 4$ [HCF=4]
 $= 2 : 3$

For fair distribution the ratio of number of pencils should be the same as the ratio of amounts contributed. So it can be said that Raju is correct and 8 pencils should go to Raju and 12 pencils to Bharath.



TRY THESE

In the given square rule paper with 5 squares, colour 3 squares red and 2 squares green.

If 10 squares are given, find how many are to be red and how many of them are to be green so that it becomes proportionate to the figure.

If there are 15 squares then colour them accordingly.

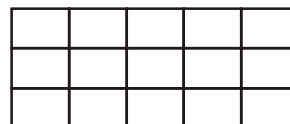
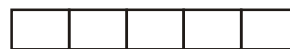

11.7 Unitary Method

Ravi went to purchase 3 kg of tomatoes. One shop keeper told him that the cost of tomatoes is ₹ 40 for 5 kg. Another shop keeper gave the price as ₹ 42 for 6 kg.

What should Ravi do? Should he purchase tomatoes from the first shop keeper or from the second? How much he has to pay for 3 kg in each case?

Sreedevi helped him. She said, "Find the price of one kg of tomatoes in each shops and compare".

$$\text{In the first shop 1 kg of tomatoes cost } ₹ \frac{40}{5} = ₹ 8$$

$$\text{In the second shop 1 kg of tomatoes cost } ₹ \frac{42}{6} = ₹ 7$$

She advised Ravi to purchase tomatoes from the second shop-keeper. Do you agree with her?

$$\begin{aligned} \text{In the second shop, price of 3 kg of tomatoes} &= ₹ 7 \times 3 \\ &= ₹ 21. \end{aligned}$$

The method in which we first find the value of one unit and then the value of the required number of units is known as the **unitary method**.

Example-8. If the cost of 12 pencils is ₹ 24, then find the cost of 10 pencils.

Solution: First we find the cost of 1 pencil by dividing ₹ 24 by 12.

$$\begin{aligned} \text{Cost of 12 pencils} &= ₹ 24 \\ \text{Cost of 1 pencil} &= 24 \div 12 = ₹ 2 \\ \text{Cost of 10 pencils} &= 2 \times 10 = ₹ 20 \end{aligned}$$

Example-9. If the cost of 6 bottles of juice is ₹ 210, then what will be the cost of 4 bottles of juice?

Solution:

$$\begin{aligned} \text{Cost of 6 bottles of juice} &= ₹ 210 \\ \text{Cost of 1 bottle of juice} &= 210 \div 6 = ₹ 35 \\ \text{Cost of 1 bottle of juice is} & ₹ 35 \end{aligned}$$

To find the cost of 4 bottles of juice, multiply the cost of 1 bottle of juice by 4

$$\text{Cost of 4 bottles of juice} = 4 \times 35 = ₹ 140$$



EXERCISE - 11.4

1. If three apples cost ₹ 45, how much would five apples cost?
2. Laxmi bought 7 books for a total of ₹ 56. How much would she pay for just 3 books?
3. Reena wants to prepare vegetable pulao. She needs 300 grams of rice, if she has to feed 4 people. How much of rice is needed if the same pulao is prepared for 7 people?
4. The cost of 16 chairs is ₹ 3600. Find the number of chairs that can be purchased for ₹ 4500.
5. A train moving at a constant speed covers a distance of 90 km. in 2 hours. Find the time taken by the train to cover a distance of 540 km at the same speed.

6. The income of Kumar for 3 months is ₹ 15000. If his monthly income remains the same then,
- How much will he earn in 5 months?
 - In how many months will he earn ₹ 95000?

7. If the cost of 7 meters of cloth is Rs 294, find the cost of 5 m of cloth.

8. A farmer has sheep and cows in the ratio 8 : 3.

- How many sheep has the farmer, if he has 180 cows?
 - Find the ratio of the number of sheep to the total number of animals the farmer has.
 - Find the ratio of the total number of animals with the farmer to the number of cows with him.
9. Are 3, 5, 15, 9 in proportion? If we change their order, can we think of proportional pairs? Write as many proportionality statements as you can for the above example.?

10. The temperature has dropped by 15 degree Celsius in the last 30 days. If the rate of temperature drop remains the same, how much more will the temperature drop in the next 10 days?

11. Fill in the following blanks:

$$\frac{15}{18} = \frac{\square}{6} = \frac{10}{\square} = \frac{\square}{30}$$

12. (i) Ratio of breadth and length of a hall is 2: 5. Complete the following table that shows some possible breadths and lengths of the hall

Breadth of the hall(in m)	10	?	40			
Length of the hall(in m)	25	50	?			

Add 3 more of your choice.

- Find the ratio of length to breadth of your classroom.
13. Geetha earns ₹ 12000 a month, out of which she saves ₹ 3000. Find the ratio of her
- Expenditure to savings
 - Savings to her income
 - Expenditure to her income.
14. There are 45 persons working in an office. The number of females is 25 and the remaining are males. Find the ratio of
- The number of females to number of males
 - The number of males to the number of females.
15. A bag of sweets contain yellow and green sweets. For every 2 yellow sweets, there are 6 green sweets. Complete this table based on the above information.

Yellow		4	6		
Green	6	12		24	
Total Sweets	8		24		40

Answer the following questions.

- i) What is the ratio of green to yellow sweets?
- ii) If you have 8 yellow sweets, how many green sweets will you have?
- iii) If there are 32 sweets in the medium sized bag, how many will be yellow?
- iv) In the super fat size bag there are 40 sweets. How many will be green?
- v) In a bag if there are 16 yellow sweets. How many total sweets are in the bag?

16. In a school survey it was found that for every 4 girls there were 5 boys. Fill in the following table.

Girls	4	8			
Boys			15	20	
Total					45

Now answer these questions:

- i) What is the ratio of girls to boys?
- ii) In a class of 27 children, how many would be girls?
- iii) There are 54 children in a class. How many are boys?
- iv) If 20 girls join in a year. How many boys would join?



WHAT HAVE WE DISCUSSED?

1. A Ratio is an ordered comparison of quantities of the same units
2. The ratio of two quantities '**a**' and '**b**' can be given in any one of the following ways.
 - i) Symbolic form $a : b$
 - ii) Fractional form $\frac{a}{b}$
 - iii) Verbal form a is to b
3. The two quantities '**a**' and '**b**' are called terms of the ratio. First quantity '**a**' is called first term or antecedent and second quantity '**b**' is called second term or consequent.
4. A ratio is in the simplest form or in the lowest terms when it is written in terms of whole numbers having no common factors other than 1.
5. Equality of ratios is called Proportion.
6. The method in which we first find the value of one unit and then the value of the required number of units is known as unitary method.





12.1 INTRODUCTION

Sirisha was getting ready in front of a mirror. She noticed something interesting written on her T-shirt.

Of the three words written on her T-shirt "THE WOW FACTOR", only "WOW" was looking the same in the mirror.

She then took out some old alphabet cards and started checking to find which alphabet remained the same in their mirror image.

Sirisha started playing with mirror. She kept the mirror along different letters and saw their reflection.

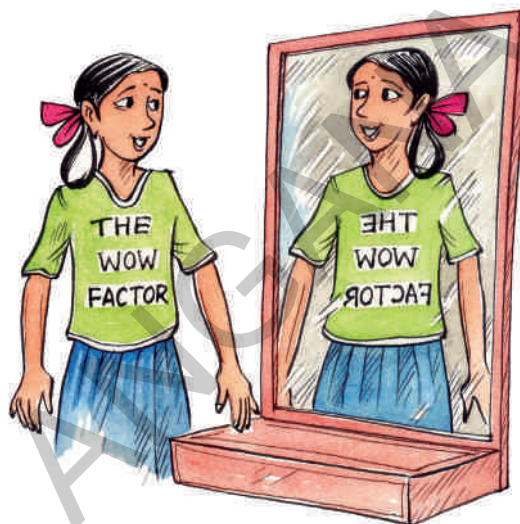

DO THIS

Match each letter with its mirror image. The dotted line with every letter shows the mirror.

	Alphabet	Image
(i)	B	Ɔ
(ii)	L	Ɔ
(iii)	N	W
(iv)	M	И
(v)	P	T
(vi)	T	J

Can you think of more such alphabets and words which will remain the same in their mirror image?



TRY THESE

1. Place a mirror along the dotted lines and draw their mirror images.

(i)

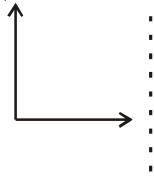

(ii)

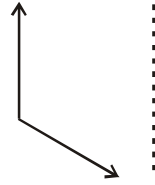

(iii)

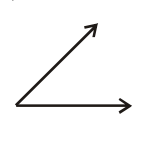

Do you observe any change?

Are angles in the images equal to the angles in the given figures?

While getting the reflection you might also observed that with the verticle line of axis of reflection symmetry the left hand side angle becomes right hand side angle in the image. similarly with the horizontal line of axis of reflection symmetry top and bottom interchange with each other.

12.2 LINE SYMMETRY

Observe the following figures. What do you notice?

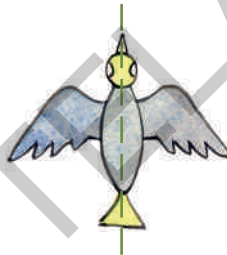

The above figures are beautiful because they are symmetric i.e. if the figure is folded along the given dotted line each part coincides with the other part exactly. It is called line symmetry and the line along which the paper is folded is called **line of symmetry or axis of symmetry**.



DO THIS

In the figures given below find which are symmetric figures.

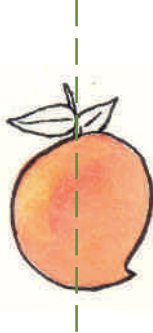

Can we find line of symmetry for every figure?

Mohit places a mirror on the dotted line and finds if the figure is completed by the image or not. Do you think what Mohit is doing right?



Observe the following figures



We can see that the first and the third figures are symmetric. First figure M has a line of symmetry vertically at its middle and third figure bird has a line of symmetry, horizontally.

Any line along which we can fold a figure so that the two parts of it coincide exactly is called a line of symmetry. It can be horizontal, vertical or diagonal.

Play with alphabet

Write English alphabet A on a tracing paper, draw a dotted line vertically on it at the centre and fold it along the dotted line. Do the two parts coincide? The dotted line is a line of symmetry and the alphabet has vertical symmetry.

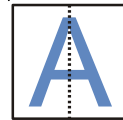

Similarly let us check the line of symmetry in the case of the alphabet B. Here we can see that the alphabet has horizontal line of symmetry.

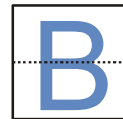

TRY THIS

Write the letters of English alphabet A to Z and find out which have

- (i) Vertical lines of symmetry.
- (ii) Horizontal lines of symmetry.
- (iii) No lines of symmetry.



DO THIS

Check whether the dotted line represents the line of symmetry or not.

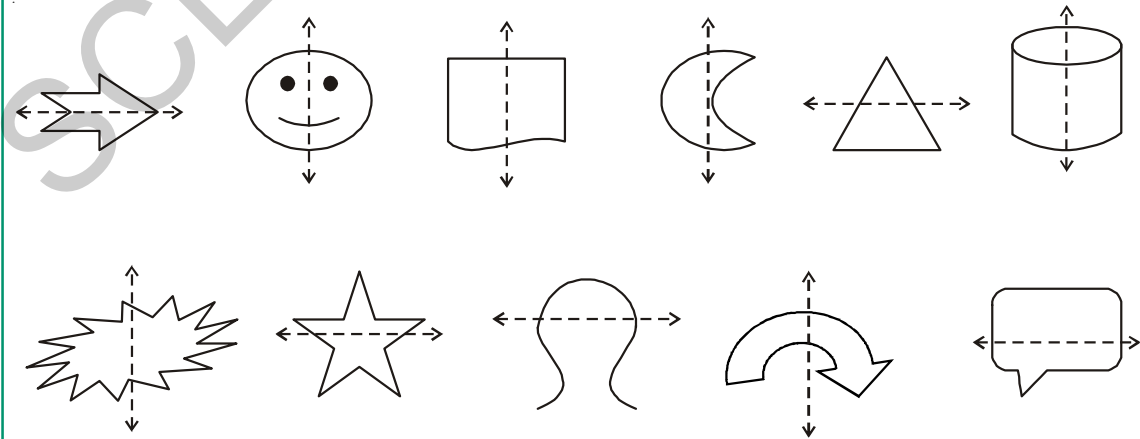



TRY THESE

Draw any five objects which have a line of symmetry.

Draw any five objects which are not symmetric.



ACTIVITY

Take a piece of paper. Fold it in half and open.

Spill a few drops of ink and fold.

Press the halves together. Now open the fold.

Will you find a symmetric design?

Draw a line of symmetry for the figure.

Make some more such symmetric figures with different colours.

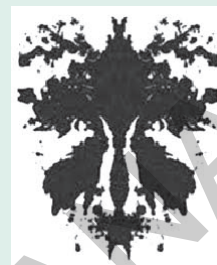

Inked-string Patterns

Fold a paper into half and open. On one half-portion, place short length of string, which is dipped in different coloured inks or paints. Now press the two halves and pull the string slowly. Study the figure you obtain. Is it symmetric? Identify the line of symmetry.



EXERCISE - 12.1

1. Check whether the given figures are symmetric or not? Draw the line of symmetry as well.

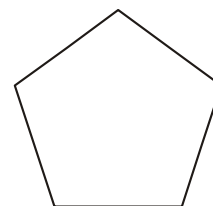
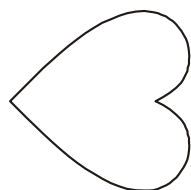
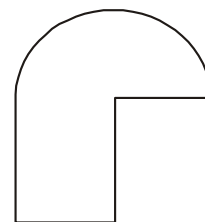
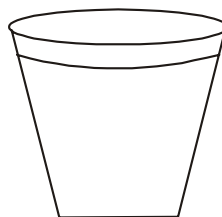
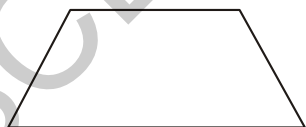

2. Draw a line of symmetry for each of the figures, wherever possible.

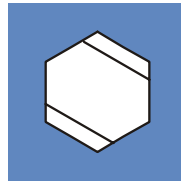
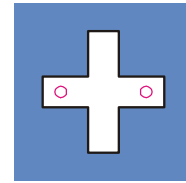

3. In the figure, ℓ is the line of symmetry. Complete the diagram to make it symmetric.

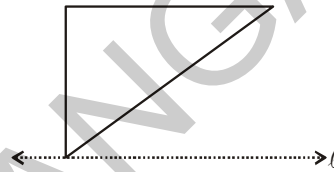

4. Complete the figures such that the dotted line is the line of symmetry.

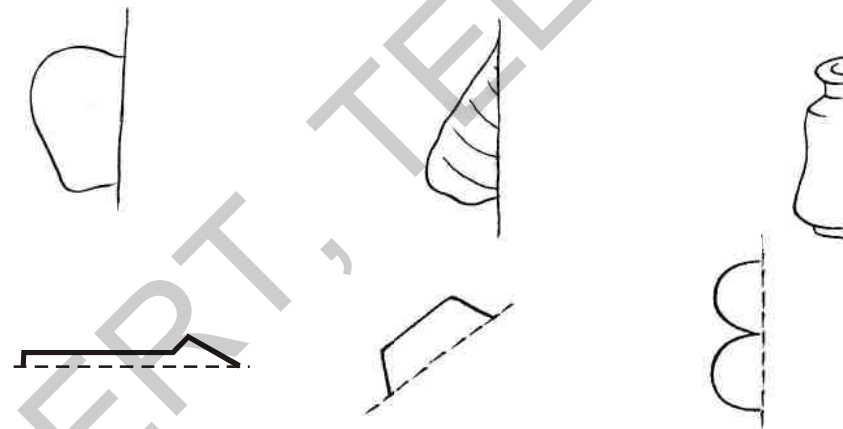

Game

There are three different shapes given below. Minakshi and Rahul try to make different symmetric shapes using the three given shapes.



Shapes

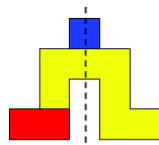

Symmetry Shapes (i)

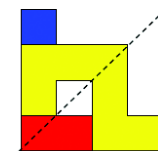

Symmetry Shapes (ii)

Trace the three shapes and make different symmetric shapes. Check with your friends. Who make more symmetric shapes.

12.3 MULTIPLE LINES OF SYMMETRY

A KITE

There are two set square in your instrument box one has angles of measure 30° , 60° , 90° . Take two such identical set-squares. Place them side by side to form a 'kite' shape as shown here.

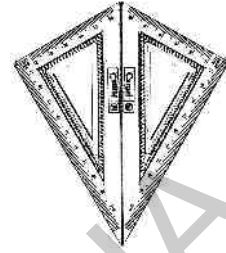

How many lines of symmetry does this shape have?

Do you think that some shapes may have more than one line of symmetry?

A Rectangle

Take a rectangular sheet (like a post-card). Fold it once length wise so that one half fits exactly over the other half. Is this fold a line of symmetry? Why?

Open it up now and again fold along its width in the same way. Is this second fold also a line of symmetry? Why?

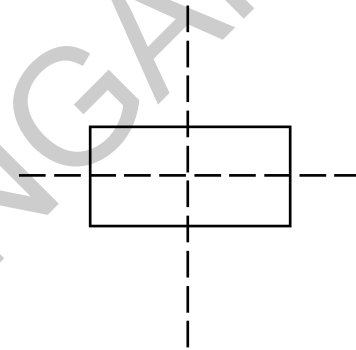

Do you find that these two lines are the lines of symmetry?

Take a square piece of paper. Fold it into half vertically so that the edges coincide. Open the fold and you will find that the two halves made by the fold are congruent. The fold at the centre becomes a line of symmetry for the paper. Try to fold the paper at different angles so that it becomes a line of symmetry. How many folds are possible?

There are four lines of symmetry for a square.

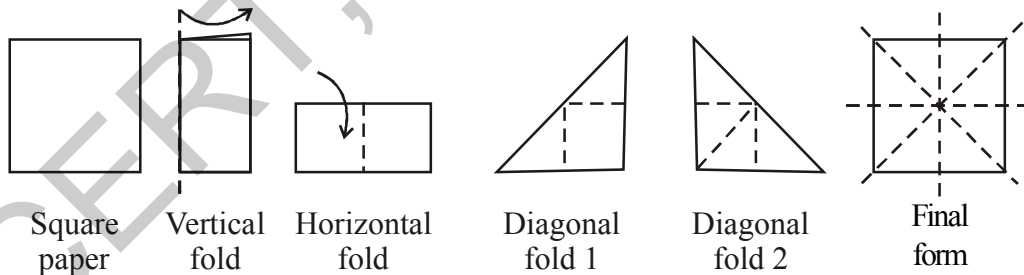

Think of an equilateral triangle and an isosceles triangle. How many lines of symmetry, does each of these figures have?

Paper cutting using symmetry

Remember how you decorate your class room on independence day or on republic day, with colour papers cut in various designs. Do you know how to cut these designs?

Take a square paper and fold at the middle vertically. Draw a design on the fold as shown in the figure and cut off the paper on edges. Then open to see a symmetric design with

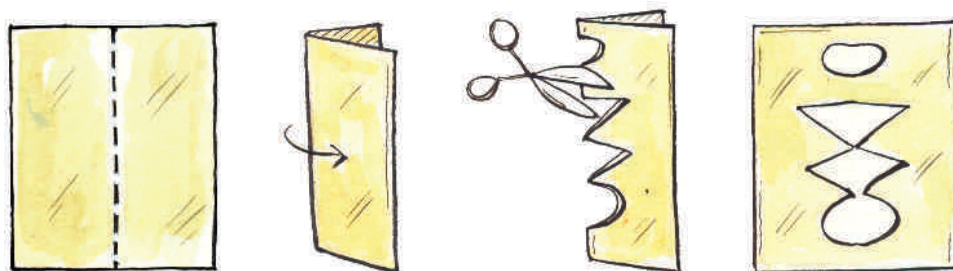

Take a square paper and fold at the middle vertically and horizontally. Draw a design on the fold as shown in the figure and cut off the paper on edges. Then open to see a symmetric design with two lines of symmetry.

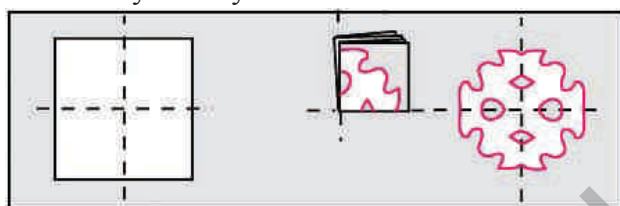

Take a square paper and fold it into half vertically, horizontally and diagonally. Draw a design on the fold as shown in the figure and cut off the paper on edges. Then open to see a symmetric design with four lines of symmetry. Create more such designs.

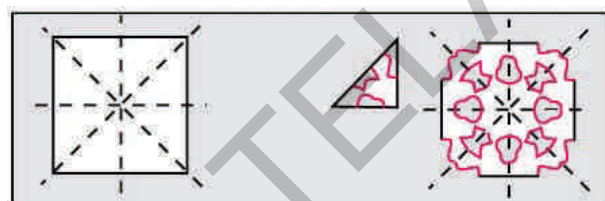

THINK, DISCUSS AND WRITE

1. If the paper is folded four times how many lines of symmetry can be formed with paper cutting.
2. To cut four similar figures side by side by folding the paper, how many folds are needed?



HOW TO DRAW A SYMMETRIC FIGURE?

- (i) Let us start drawing a figure as shown in the adjacent figure.
- (ii) We want to complete it so that we get a figure with two lines of symmetry. Let the two lines of symmetry be ℓ and m .
- (iii) Draw a curve so that it is a mirror image of the previous curve in line ℓ .
- (iv) Draw a curve so that it is a mirror image of the previous curves in the symmetric line m .

Try to make some more figures that have two lines of symmetry.

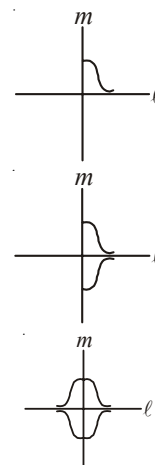



EXERCISE - 12.2

1. Write any five man made things which have two lines of symmetry.
2. Write any five natural objects which have two or more than two lines of symmetry.
3. Find the number of lines of symmetry for the following shapes.

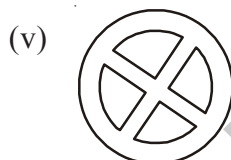
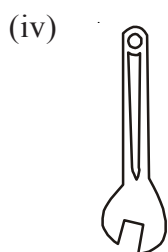
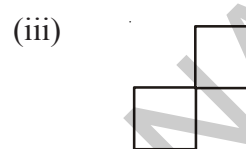
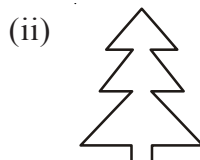

4. Draw the possible number of lines of symmetry.

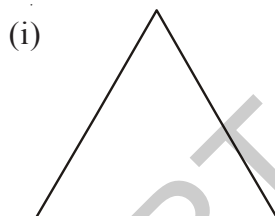

Equilateral triangle

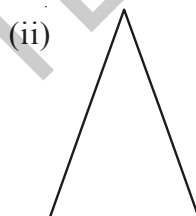

Isosceles triangle

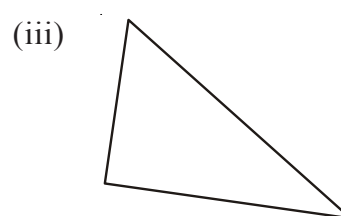

Scalene triangle

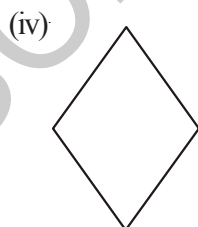

Rhombus

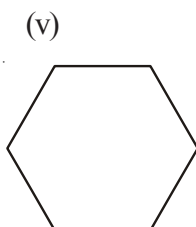

Hexagon

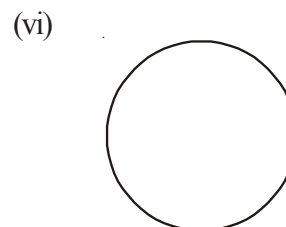

Circle

5. From the above problem, complete the following table.

Shape	Number of lines of symmetry
i) Equilateral triangle	
ii) Isosceles triangle	
iii) Scalene triangle	
iv) Rhombus	
v) Regular Hexagon	
vi) Circle	

6. A few folded sheets and designs drawn about the fold are given. In each case, draw a rough diagram of the complete figure that would be seen when the design is cut off.

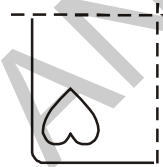

Paper is folded vertically once Paper is folded vertically & horizontally



Classroom project

Take a grid paper. A grid paper is what you would have used in your arithmetic notebook in earlier classes. Draw a vertical line of symmetry on the paper (as shown in the figure). Colour any one square on one side of the vertical axis. Then ask a student to find the square which is symmetrical to the first one and colour it. After she does this, she can choose any other square and colour it also. The next student will now do the same.

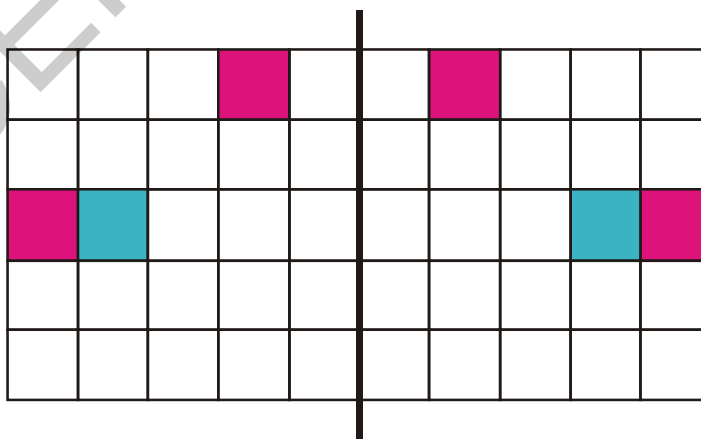



Home project

Collect symmetrical figures from your environment and prepare a scrap book. Also collect Rangoli patterns and draw them in your scrap book. Try and locate symmetric portions of these patterns along with the lines of symmetry. Here are few examples:

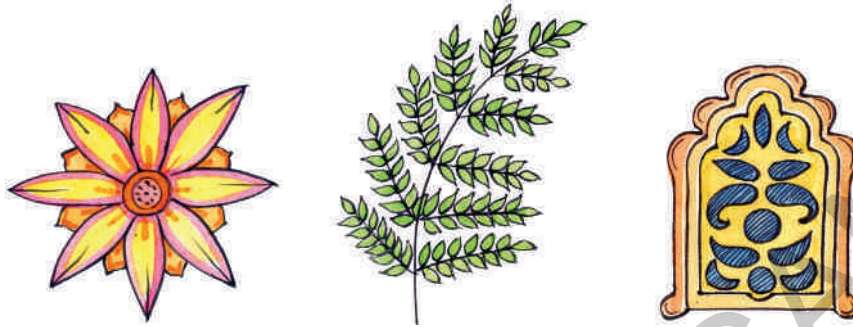

WHAT HAVE WE DISCUSSED?

1. A figure is said to have line symmetry if a line can be drawn dividing the figure into two identical parts. This line is called a line of symmetry.
2. A figure may have no line of symmetry, only one line of symmetry, two lines of symmetry or multiple lines of symmetry. Here are some examples.

Number of lines of symmetry	Example
No line of symmetry	A scalene triangle
Only one line of symmetry	An isosceles triangle
Two lines of symmetry	A rectangle
Three lines of symmetry	An equilateral triangle
Countless lines of symmetry	A circle

3. The line symmetry is closely related to mirror reflection. When dealing with mirror reflection, we have to take into account the left \leftrightarrow right changes in orientation.
4. Symmetry has plenty of applications in everyday life as in art, architecture, textile technology, design creations, geometrical reasoning, Kolams, Rangoli etc.





13.1 INTRODUCTION

Copy the following shapes in your notebook with a pencil.

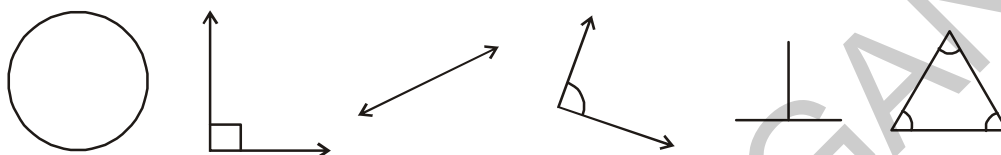

Do they look exactly the same? Measure their sides and angles by ruler and protractor.

What do you find? You will find their measures are not exactly the same. To make them exactly same we need to draw them of accurate sizes. For this we need to use tools. We will learn to construct such figures, in this chapter by using compasses, ruler and protractor. Ruler, compasses and protractor are our tools. These are all a part of our geometry box. Let us observe the geometry box.

What all is there in the geometry box? Besides the ruler, compasses and protractor we have a divider and set squares. The ruler is used for measuring line segments, a compasses for drawing circles and arcs, protractor measures angles and the divider is to make equal line segments or mark points on a line.

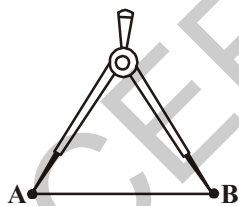

Divider

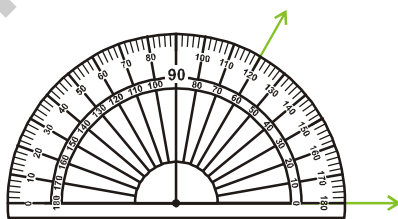

Protractor

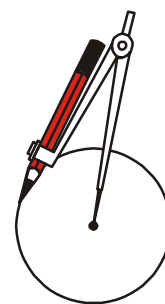

Compass

13.2 A LINE SEGMENT

Let A and B be two points on a paper. Then the straight path from A to B is called a line segment AB, denoted by \overline{AB} .



The distance between the points A and B is called the length of AB. Thus a line segment has a definite length, which can be measured.

13.2.1 Construction of a Line Segment of a given Length

We can construct a line segment of given length in two ways.

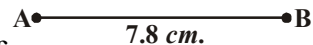

- By using ruler:** Suppose we want to draw a line segment of length 7.8 cm. We can do it in this way

Place the ruler on paper and hold it firmly. Mark a point with a sharp pencil against 0 cm mark of the ruler. Name the point as A. Mark another point against 8 small divisions just after the 7 cm mark. Name this point as B. Join points A and B along the edge of the ruler. AB is the required line segment of length 7.8 cm

- By using Compasses:**

Suppose we want to draw a line segment of length 5.3 cm

Steps of Constructions:

Step-1: Draw a line l . Mark a point A on the line l .



Step-2: Place the metal pointer of the compasses on the zero mark of the ruler. Open the compasses so that pencil point touches the 5.3 cm mark on the ruler.

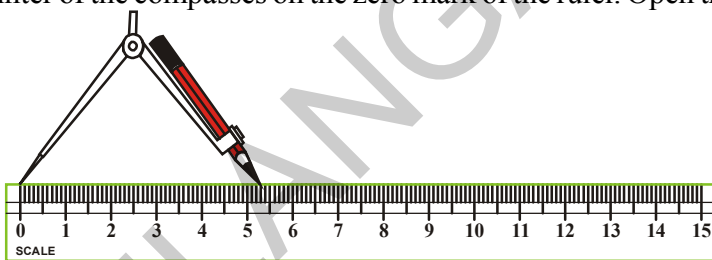

Step-3: Place the pointer on A on the line l and draw an arc to cut the line. Mark the point where the arc cuts the line as B.

Step-4: On the line l , we got the line segment AB of required length (5.3 cm).

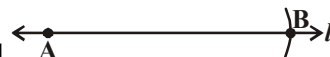

EXERCISE - 13.1

- Construct a line segment of length 6.9 cm using ruler and compasses.
- Construct a line segment of length 4.3 cm using ruler.
- Construct a line segment MN of length 6 cm. Mark any point O on it. Measure MO, ON and MN. What do you observe?
- Draw a line segment \overline{AB} of length 12 cm. Mark a point C on the line segment \overline{AB} , such that $\overline{AC} = 5.6$ cm. What should be the length of \overline{CB} ? Measure the length of \overline{CB} .
- Given that $AB = 12$ cm



- From the above figure measure the lengths of the following line segments.
 - \overline{CD}
 - \overline{DB}
 - \overline{EA}
 - \overline{AD}
 - Verify $\overline{AE} - \overline{CE} = \overline{AC}$?
- $\overline{AB} = 3.8$ cm. Construct \overline{MN} by compasses such that the length of $\overline{MN} = 3 \overline{AB}$. Verify this with the help of a ruler.

13.3 Construction of a Circle

Look at the wheel shown here. Observe that every point on its boundary is at an equal distance from its centre. Think of other such objects that are of this shape.

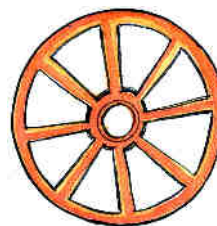

How to draw objects and figures having this shape. We can use many things like bangle, bowl top, plate and other things. These are however of a definite size. To draw a circle of given radius we use the compasses.

We use the following steps to construct a circle

Steps of Construction:

Step-1: Open the compasses for required radius. Let us say for example it is 3.7 cm

Step-2: Mark a point with sharp pencil. This is the centre. Mark it as O.

Step-3: Place the pointer of the compasses firmly at O.

Step-4: Without moving its metal point. Slowly rotate the pencil till it comes back to the starting point.



TRY THESE

Construct two circles with same radii (radius) in such a way that

- (i) the circles intersect at two points
- (ii) touch each other at one point only.

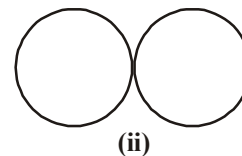
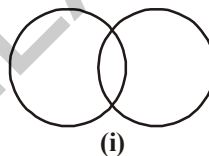

EXERCISE - 13.2

1. Construct a circle with centre M and radius 4 cm
2. Construct a circle with centre X and diameter 10 cm
3. Draw four circles of radii 2 cm, 3 cm, 4 cm and 5 cm with the same centre P.
4. Draw any circle and mark three points A, B and C such that
 - (i) A is on the circle
 - (ii) B is in the interior of the circle
 - (iii) C is in the exterior of the circle.

ACTIVITY

Make a circle of desired radius in your note book. Make a point on it. Put compasses on it and make a circle without changing the radius. It will cut the circumference at two points. On both points repeat the process again, you will get a beautiful picture as shown. Colour it as you wish.

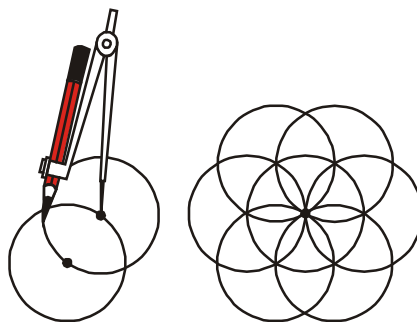

13.4 PERPENDICULARS

You know that two lines (or rays or segments) are said to be perpendicular if they intersect such that the angles formed between them are right angles.

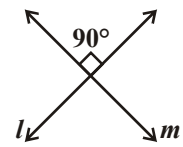

In the figure, the lines l and m are perpendicular.

The corners of a foolscap paper or your notebooks indicate lines meeting at right angles. Think other such objects where the lines meeting are perpendicular. Give five examples.



1. Perpendicular through a Point on a given line

ACTIVITY

Take a tracing paper and draw a line l on it.

Mark a point P lying on this line. Now, we want to draw a perpendicular on l through P .

We simply fold the paper at point P such that the lines on both sides of the fold overlap each other.

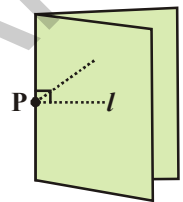

When we unfold it, we find that the crease is perpendicular to l .

THINK, DISCUSS AND WRITE

How would you check whether it is perpendicular or not? Note that it passes through P as required.



13.4.1 Constructing Perpendicular Bisector of the given Line Segment

Steps of Construction

Step-1: Draw a line segment \overline{AB} .

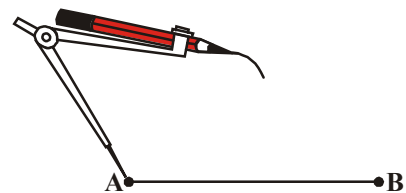

Step-2: Set the compasses as radius more than half of the length of \overline{AB} .

Step-3: With A as centre, draw arcs below and above the line segment.

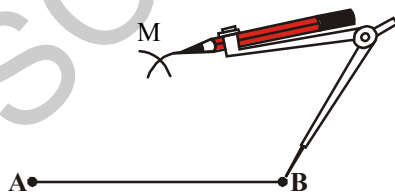

Step-4: With the same radius and B as centre draw two arcs above and below the line segment to cut the previous arcs. Name the intersecting points of arcs as M and N .

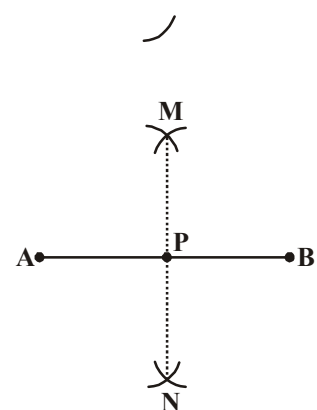

Step-5: Join the points M and N . Then, the line MN is the required perpendicular bisector of the line segment AB . Line MN intersects line segment AB at P .

Observe another method.

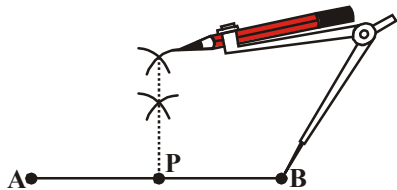

DO THIS

Measure the lengths of \overline{AP} and \overline{BP} in both the constructions. Are they equal ?

THINK, DISCUSS AND WRITE

In the construction of perpendicular bisector in step 2. What would happen if we take the length of radius to be smaller than half the length of \overline{AB} ?



13.4.2 Perpendicular to a Line, through a Point which is not on it

Steps of Construction:

Step-1: Draw a line l and a point A not on it.

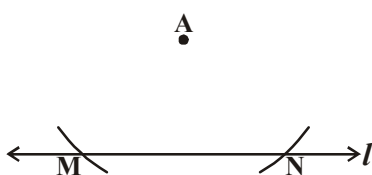

Step-2: With A as centre draw an arc which intersects the given line l at two points M and N.

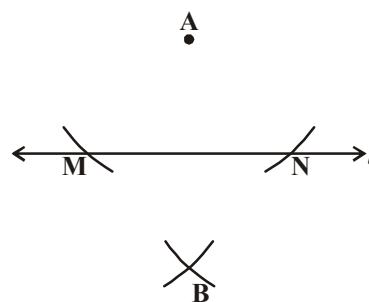

Step-3: Using the same radius and with M and N as centres construct two arcs that intersect at a point, say B on the other side of the line.

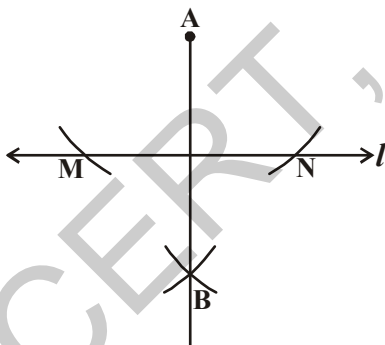

Step-4: Join A and B. AB is a perpendicular of the given line l .



EXERCISE - 13.3

1. Draw a line segment $PQ = 5.8$ cm and construct its perpendicular bisector using ruler and compasses.
2. Ravi made a line segment of length 8.6 cm. He constructed a bisector of AB on C. Find the length of AC & BC.
3. Using ruler and compasses, draw $AB = 6.4$ cm. Find its mid point.

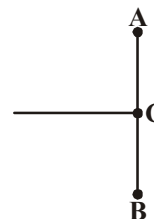

13.5 DRAWING ANGLES USING PROTRACTOR

Let us construct $\angle PQR = 40^\circ$.

Steps of construction:

Step-1: Draw a ray QR of any length. 

Step-2: Place the centre point of the protractor at Q and the line aligned with the \overline{QR}

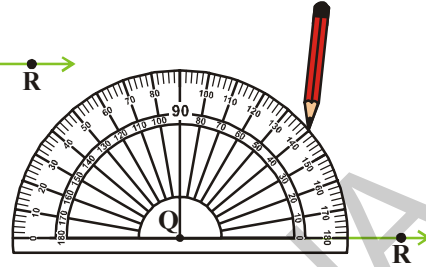

Step-3: Mark a point P at 40° .

Step-4: Join Q, P. Then $\angle PQR$ is the required angle.

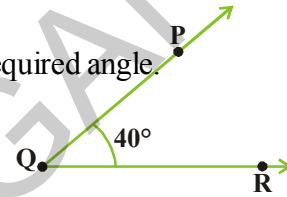
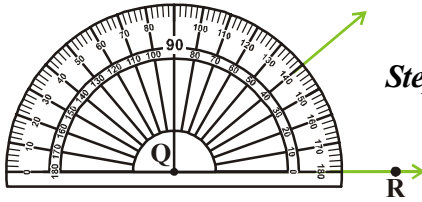

13.6 CONSTRUCTING A COPY OF AN ANGLE OF UNKNOWN MEASURE

Suppose an angle (whose measure we do not know) is given and we want to replicate this angle using compass and scale.

Let $\angle A$ is given, whose measure is not known.

Step-1: Draw a line l and choose a point P on it.

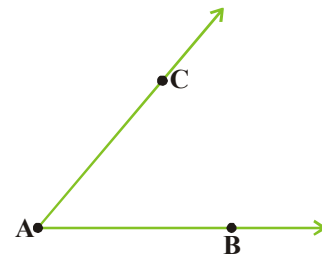

Step-2: Now place the compasses at A and draw an arc to cut the rays AC and AB.

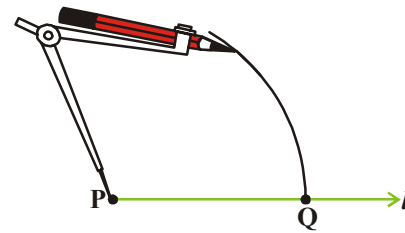
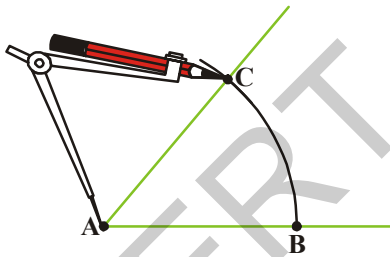

Step-3: Use the same compasses setting to draw an arc with P as centre, cutting l at Q.

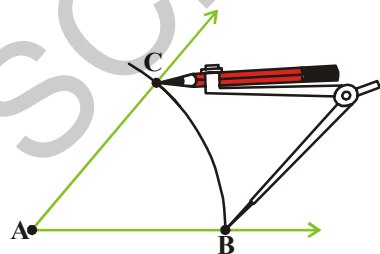

Step-4: Set your compasses with \overline{BC} as the radius.

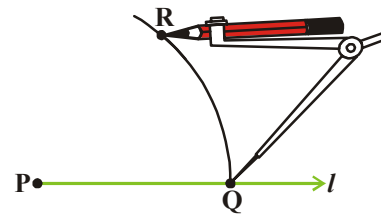

Step-5: Place the compasses pointer at Q and draw an arc to cut the existing arc at R.

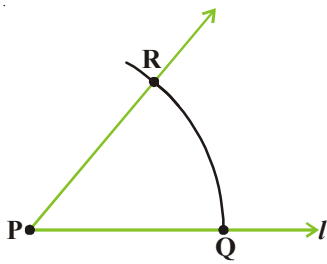

Step-6: Join PR. This gives us $\angle RPQ$. It has the same measure as $\angle CAB$.

This means $\angle QPR$ has same measure as $\angle BAC$.

13.7 CONSTRUCTION TO BISECT A GIVEN ANGLE

Take a tracing paper. Mark a point O on it. With O as initial point, draw two rays \overline{OA} and \overline{OB} . You get $\angle AOB$. Fold the sheet through O such that the rays \overline{OA} and \overline{OB} coincide. Let \overline{OC} be the crease of paper which is obtained after unfolding the paper.

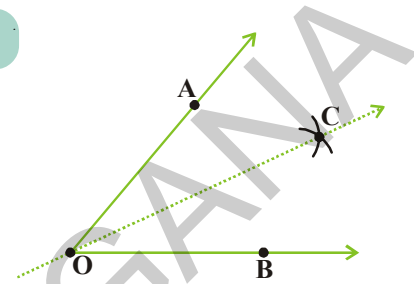

\overline{OC} is clearly a line of symmetry for $\angle AOB$.

Measure $\angle AOC$ and $\angle COB$. Are they equal? \overline{OC} the line of symmetry, is therefore known as the angle bisector of $\angle AOB$.

Let an angle say $\angle MON$ be given.

Steps of Construction:

Step-1: With O as centre and any convenient radius, draw an arc PQ cutting OM and ON at P and Q respectively.

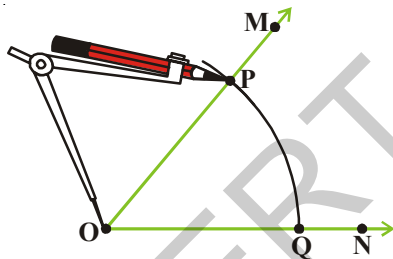

Step-2: With P as centre and any radius slightly more than half of the length of PQ, draw an arc in the interior of the given angle.

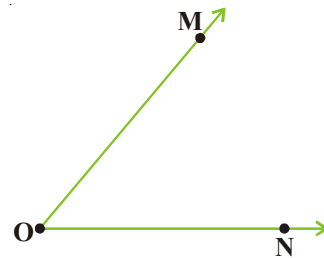

Step-3: With Q as centre and without altering radius (as in step 2) draw another arc in the interior of $\angle MON$.

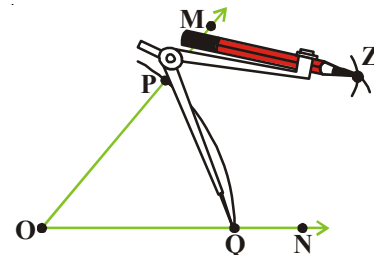

Let the two arcs intersect at Z.

Step-4: Draw ray \overline{OZ} .

Then \overline{OZ} is the desired bisector of $\angle MON$.

Observe $\angle MOZ = \angle ZON$.

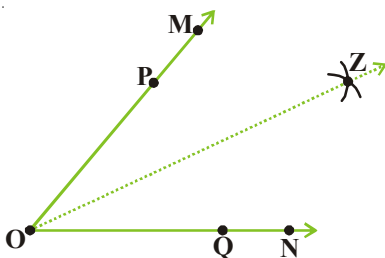



EXERCISE - 13.4

- Draw the following angles with the help of a protractor .
i) $\angle ABC = 65^\circ$ ii) $\angle PQR = 136^\circ$ iii) $\angle Y = 45^\circ$ iv) $\angle O = 172^\circ$
- Copy the following angles in your note book and draw their bisector:

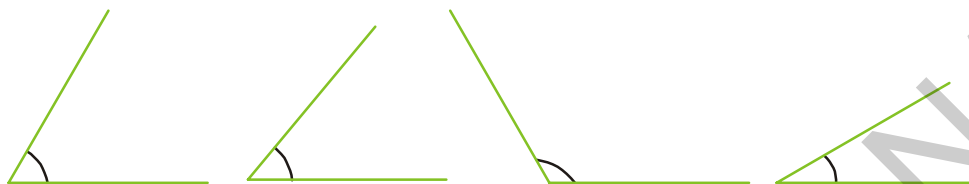

13.8 CONSTRUCTING ANGLES OF SPECIAL MEASURES

There are some elegant and accurate methods to construct some angles of special sizes which do not require the use of the protractor. A few have been discussed here.

You learnt the construction of any given angle by using a protractor. Now we will learn construction of some angles by using compasses only.

13.8.1 Construction of 60° Angle

Steps of construction:

Step-1: Draw a line l and mark a point O on it. 

Step-2: Place the pointer of the compasses at O and draw an arc of convenient radius which cuts the line l at a point say, A .

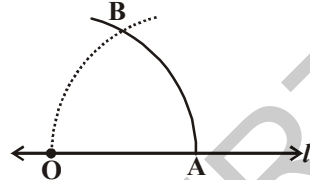

Step-3: With the pointer at A (as centre) and the same radius as in the step-2. Now draw an arc that passes through O . Let the two arcs intersect at B .

Step-4: Join O, B . We get $\angle AOB$ whose measure is 60° .

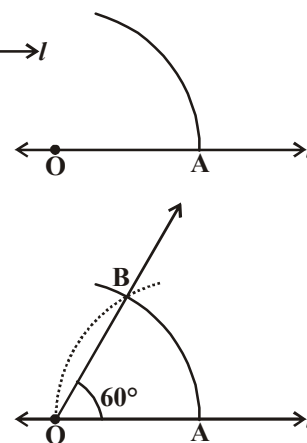

Use protractor and draw 60° . Now compare two measurements. Are they equal?

13.8.2 Construction of 120° Angle

An angle of 120° is nothing but twice of an angle of 60° . Therefore, it can be constructed as follows:

Steps of construction:

Step-1: Draw any ray OA . 

Step-2: Place the pointer of the compasses at O . With O as centre and any convenient radius draw an arc cutting OA at M .

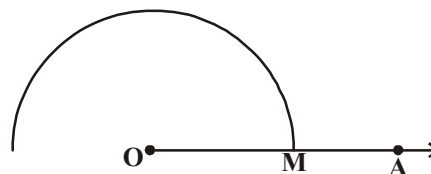

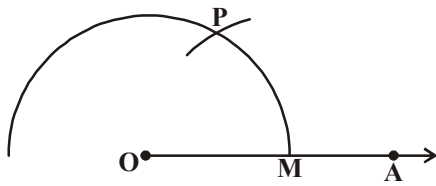

Step-3: With M as centre and without altering radius (as in step 2) draw an arc which cuts the first arc at P.

Step-4: With P as centre and without altering the radius (as in step 2) draw an arc which cuts the first arc at Q.

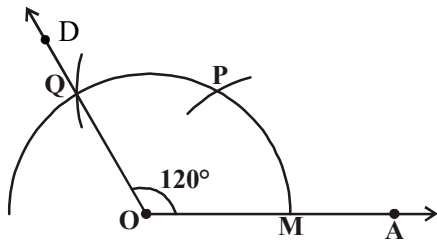
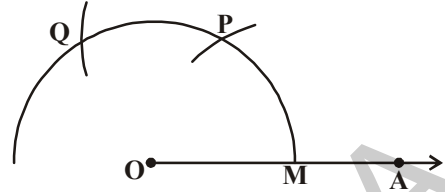

Step-5: Join O, Q and extend upto D. Then $\angle AOD = 120^\circ$ is the required angle.



Do This

Construct angles of 180° , 240° , 300° .

13.8.3 Construction of 30° Angle

Steps of Construction:

Draw an angle of 60° as discussed above. Name it as $\angle POQ$.

Bisect this angle as shown earlier to get two angles each of 30° .

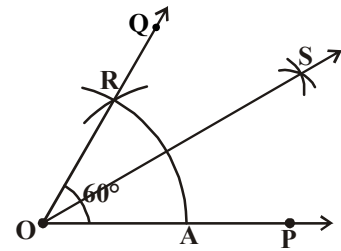

13.8.4 Construction of 90° Angle

Look at the given figure

$\angle AOP = 60^\circ$, $\angle POQ = 60^\circ$ and

$\angle AOQ = 120^\circ$

We want to construct an angle of 90° .

We know that $90^\circ = 60^\circ + 30^\circ$ and

also $90^\circ = 120^\circ - 30^\circ$

So, we need to bisect $\angle POQ$ to get an angle of 30° .

$\angle BOP = 30^\circ$ and $\angle AOB = 90^\circ$

Think of one more way to construct a 90° angle.

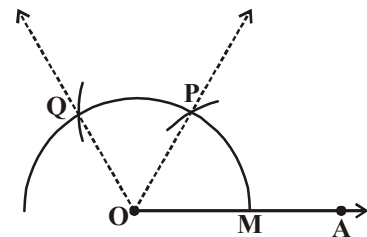
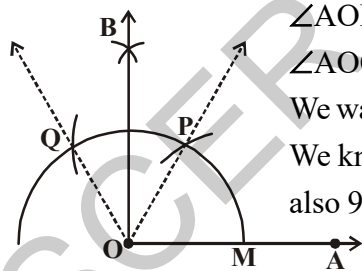

Step-1: With 'P' as a centre and convenient radius draw an arc above PQ.

Step-2: With 'Q' as a centre and with same radius draw another arc intersecting the previous arc at 'B'.

Step-3: Draw the ray \overline{OB} . $\angle AOB = 90^\circ$ which is our required angle.



Do This

Construct an angle of 45° by using compasses.



EXERCISE - 13.5

- Construct $\angle ABC = 60^\circ$ without using protractor.
- Construct an angle of 120° with using protractor and compasses.
- Construct the following angles using ruler and compasses. Write the steps of construction in each case.
 - 75°
 - 15°
 - 105°
- Draw the angles given in Q.3 using a protractor.
- Construct $\angle ABC = 50^\circ$ and then draw another angle $\angle XYZ$ equal to $\angle ABC$ without using a protractor.
- Construct $\angle DEF = 60^\circ$. Bisect it, measure each half by using a protractor.



WHAT HAVE WE DISCUSSED?

This chapter deals with methods of drawing geometrical shapes.

- We use the following geometrical instruments to construct shapes:
 - A graduated ruler
 - The compasses
 - The divider
 - Set-squares
 - The protractor
- Using the ruler and compasses, the following constructions can be made:
 - A circle, when the length of its radius is known.
 - A line segment, if its length is given.
 - A copy of a line segment.
 - A perpendicular to a line through a point
 - on the line
 - not on the line
 - The perpendicular bisector of a line segment of given length.
 - An angle of a given measure.
 - A copy of an angle.
 - The bisector of a given angle.
 - Some angles of special measures such as:
 - 90°
 - 45°
 - 60°
 - 30°
 - 120°
 - 135°



Fun with curves

Mark 10 points at 1cm intervals on two lines at right angles, numbering them 1 to 10. Join 1 to 10, 2 to 9, 3 to 8, ... etc. so that the sum is 11 as shown in the figure. The result is a curve. Make some pictures using this idea.

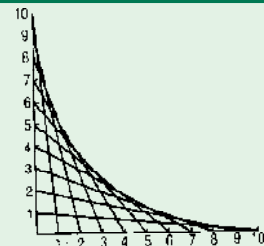



14.1 INTRODUCTION

Pictures of some objects are given below.



Carefully study the shape of these objects. Classify them according to their shape in this table:

Table - 14.1

Shape	Object
Like a match box	
Like a ball	
Like a wooden log	
Like a dice	
Like a cap	

14.2 3D-SHAPES

We have learnt about triangles, squares, rectangles etc. in the previous classes. All these shapes spread in two directions only and thus called two-dimensional or 2D shapes.

All solid objects like above, have a length, breadth and height or depth. Thus they are called three dimensional or 3D-shapes. Now, we will learn about various 3 dimensional or 3D shapes.

14.2.1 Cuboid

The shapes like a closed match box are examples of a cuboid. Touch your hand on the top of the match box. This plane surface is the face of match box. How many faces does a match box have?

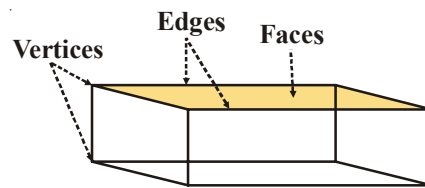

The sides of the faces are the edges. How many edges does a match box have?

The corners of the edges are the vertices of the match box. How many vertices does a match box have?

Now take an eraser, whose shape is similar to that of a match box. Touch your hand along its faces, edges and vertices.

Does the eraser have the same number of faces, edges and vertices as that of match box? You will find this to be true.

Objects like match boxes, erasers etc. are in the shape of a cuboid and have 6 faces, 12 edges and 8 vertices.

14.2.2 Cube

A dice is an example of a cube. Take a dice. Locate its faces, edges and vertices. Count them. How many faces, edges and vertices does a dice have?

You will find that a die has 6 faces, 12 edges and 8 vertices, same as that of a cuboid. Then what is the difference between a cube and a cuboid? You will find that the length, breadth and height of a cube are all same, but in a cuboid they are different. Verify this by measuring the length, breadth and height of an eraser and a die.

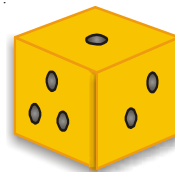

TRY THESE

- What is the shape of the face of a cube?
 - What is the shape of the face of a cuboid?
- Ramesh has collected some boxes in his room. Pictures of these are given here. How many are cubes and how many are cuboids.
- Ajith has made a cuboid by arranging cubes of 2 centimeter each. What is the length, breadth and height of the cuboid so formed?

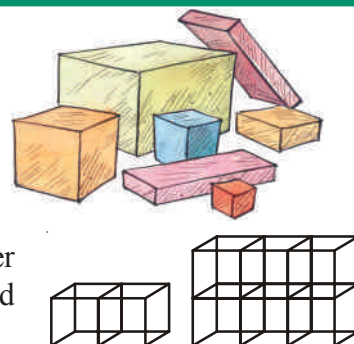

14.2.3 Cylinder

Objects like a wooden log, a piece of pipe, a candle, tube light are in the shape of a cylinder. Take a candle. Slice it on the top as shown in the *fig.1*. Lay it down horizontally (*fig.2*). Can you roll it?

Now erect candle up vertically (*fig.3*). Does it roll?

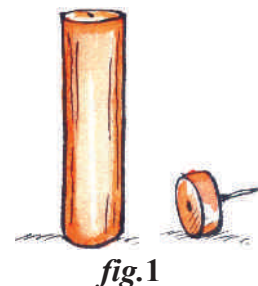

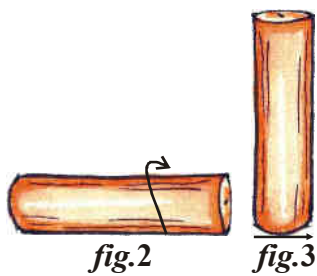

The surface on which the candle rolls is called its curved surface. The surface on which the candle does not roll, but stands on vertically is the base, which is circular in shape.

Now what is the height and width of the candle? Look at the height and width of the cylinder shown in the figure.

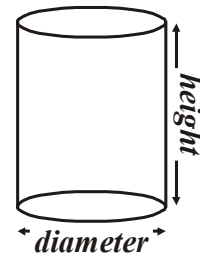

14.2.4 Cone

Raju wants to buy a special cap for his birthday. He asked Leela to come along with him. Leela said that there is no need to go to the market as they can make the cap on their own.

Would you like to make a cap? Let us try.

Draw a circle on a thick paper using a compass. Draw two lines from the centre to the circumference as shown in the fig. (ii)

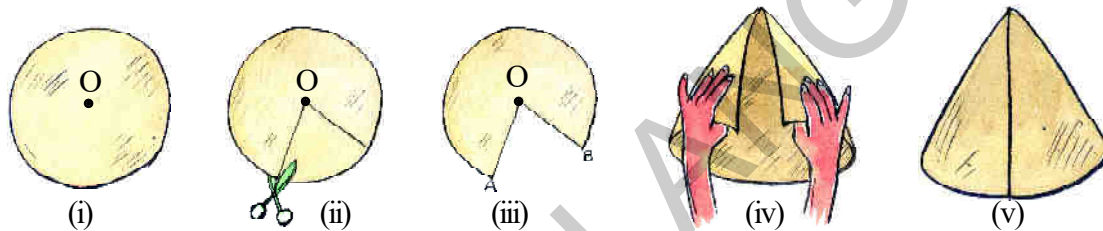

Cut this part with scissors it will look like. (fig. iii)

Now join \overline{OA} and \overline{OB} with adhesive tape. Your cap is ready now. Decorate it as you wish.



Raju inverted the cap and said "oh! it looks like an ice-cream cone."

Here is a figure of a cone. \overline{OA} is the radius of the circular part and \overline{OC} is the height of the cone.

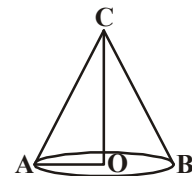

THINK, DISCUSS AND WRITE

What is the difference between a cylinder and a cone with respect to the number of faces, vertices and edges? Discuss with your friends.



14.2.5 Sphere

Balls, laddoos, marbles etc. are all in the shape of a sphere. They roll freely on all sides.

Can you call a coin a sphere? Does it roll on all its sides? What about a bangle?

You may have seen lemon in your daily life. When we cut it horizontally it looks like the shape shown in the figure. The shape of such an object is called hemisphere.





DO THIS

Fill the table accordingly:

S. No.	Object	Shape	Slides only	Roll only	Slides and rolls
1.	Cell	Cylindrical	×	×	✓
2.	Ball				
3.	Oil can				
4.	Biscuit packet				
5.	Coin				
6.	Marble				
7.	Orange				

The cylinder, the cone and the sphere have no straight edges. What is the base of a cone? Is it a circle? The cylinder has two bases. What shape is its base? Of course, a sphere has no face! Think about it.

14.2.6 Prism

Here is a diagram of a **prism**. You might have seen it in the laboratory. Two of its faces is in the shape of triangle. Other faces are either in the shape of rectangle or parallelogram. It is a triangular prism.

If the prism has a rectangular base, it is a rectangular prism. Can you recall another name for a rectangular prism?

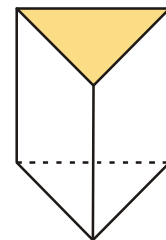

Prism

14.2.7 Pyramid

A **pyramid** is a solid shape with a base and a point vertex, the other faces are triangles. All the triangular faces meet at vertex of the prism.

Here is a square pyramid. Its base is a square. Can you imagine a triangular pyramid? Attempt a rough sketch of it.

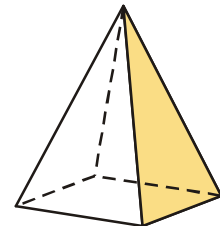

Pyramid



ACTIVITY

Take a sheet of chart. Draw a triangle with equal sides on the chart, cut it. Then using this triangle cut out three more triangles of exactly same size from the chart. Join the edges of the four triangles, thus formed in order to make a closed object. This object is in the shape of a tetrahedron or triangular pyramid.

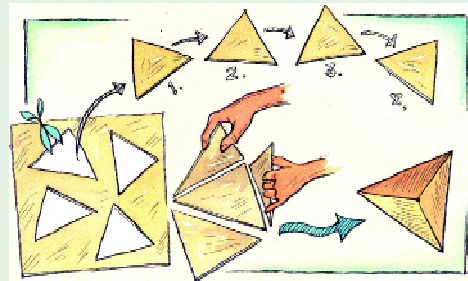



EXERCISE-14.1

1. A triangular pyramid has a triangle at its base. It is also known as a tetrahedron. Find

No. of Faces : _____
 No. of Edges : _____
 No. of Vertices : _____

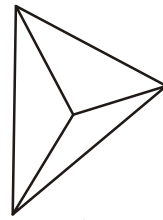

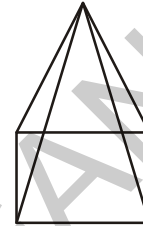

2. A square pyramid has a square at its base. Find

No. of Faces : _____
 No. of Edges : _____
 No. of Vertices : _____



3. Fill the table

Shape	No. of curved surfaces	No. of plane surfaces	No. of Vertices
			
			
			

4. A triangular prism is often in the shape of a kaleidoscope. It has triangular faces. Find

No. of triangular Faces : _____
 No. of rectangular Faces : _____
 No. of Edges : _____
 No. of Vertices : _____

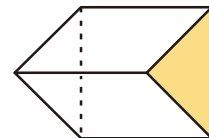

14.3 POLYGONS

We have learnt about open and closed figures in the chapter 'Basic Geometrical Ideas'. See the figures given below. Which of the following figures are open and which are closed?



(i)

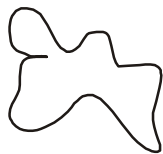

(ii)

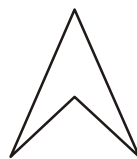

(iii)

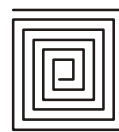

(iv)



(v)

A figure is a polygon if it is a closed figure, formed with a definite number of line segments.

Some examples are shown here.

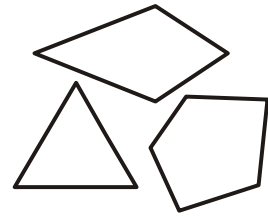





 **DO THIS**

1. Draw ten polygons with different shapes in your notebook.
2. Use match-sticks or broom-sticks and form closed figures using:

(i) Six sticks	(ii) Five sticks	(iii) Four sticks
(iv) Three sticks	(v) Two sticks	

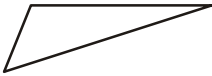
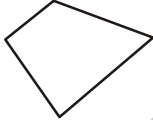
In which case was it not possible to form a polygon? Why?

You will find that you could not form a polygon using two sticks. A polygon must have at least three sides. A polygon with three sides is called a triangle. Study the table given below and learn the names of the various types of polygons. Fill the blanks in the table.

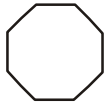
Figure	No. of sides	Name
	3	Triangle
	4	Quadrilateral
	-	Pentagon
	-	Hexagon
	7	Septagon
	-	Octagon



TRY THIS

Find out the differences:

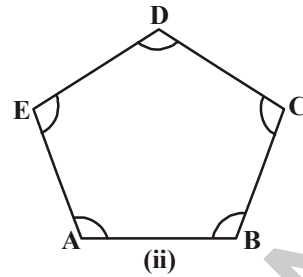
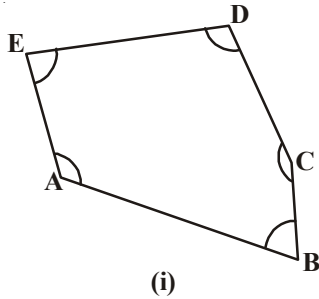

Measure the lengths of the sides and angles of (i) and (ii). What did you find?

14.3.1 Regular Polygon

A polygon with all equal sides, and all equal angles is called a regular polygon. Equilateral triangles and squares are examples of regular polygons.

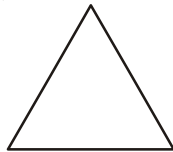

Equilateral triangle : A triangle with all sides and all angles equal



Square : A quadrilateral with all sides and all angles equal.

Similarly, if all the sides and all the angles of a pentagon, hexagon, septagon and octagon are equal they are called regular pentagon, regular hexagon, regular septagon and regular octagon respectively.



EXERCISE - 14.2

1. Examine whether the following are polygons if not why?



(i)

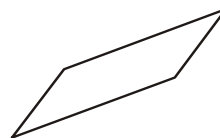

(ii)

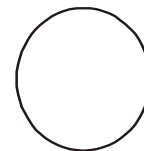

(iii)

2. Count the number of sides of the polygons given below and name them:

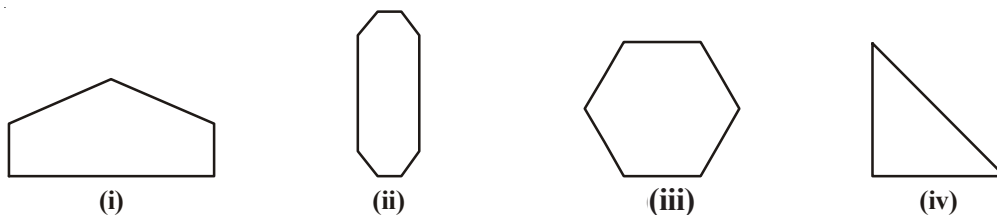

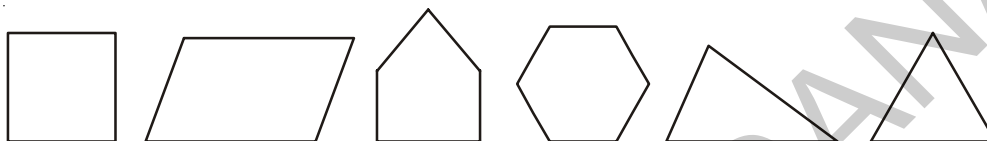

3. Identify the regular polygons among the figures given below:

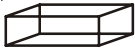

WHAT HAVE WE DISCUSSED?

1. Various boxes are normally in the shapes of cubes and cuboids:

Shapes	Faces	Edges	Vertices
	6	12	8
	6	12	8

- Ice-cream cones, joker's caps etc. are in the shape of cone.
- Tins, oil drums, wooden logs are in the shape of a cylinder.
- Balls, laddoos etc. are in the shape of a sphere.
- A polygon is a closed figure made up of line segments.
- If all the sides and angles of a polygon are equal, it is called a regular polygon.



Answers



EXERCISE - 1.1

1. **Greatest number** **Smallest number**
- i 15892 15370
- ii 25800 25073
- iii 44687 44602
- iv 75671 75610
- v 34899 34891
2. i 375, 1475, 4713, 15951 ii 9347, 12300, 19035, 22570
3. i 89715, 89254, 45321, 1876 ii 18500, 8700, 3900, 3000
4. i < ii > iii > iv >
5. i Seventy two thousand six hundred forty two
- ii Fifty five thousand three hundred forty five
- iii Sixty six thousand six hundred
- iv Thirty thousand three hundred one
6. i 40270 ii 14064 iii 9700 iv 60000.
7. The greatest number is 7430 and the smallest number is 3047
8. i 1000 ii 9999 iii 10000 iv 99999



EXERCISE - 1.2

1. i 90 ii 420 iii 3950 iv 4410
2. i 700 ii 36200 iii 13600 iv 93600
3. i 3000 ii 70000 iii 9000 iv 4000
4. i 3407 ii 12351 iii 30525 iv 99999
5. i $4000 + 300 + 40 + 8$ ii $30000 + 200 + 10 + 4$
- iii $20000 + 2000 + 200 + 20 + 2$ iv $70000 + 5000 + 20 + 5$



EXERCISE - 1.3

1. i 1,12,45,670 ii 2,24,02,151
- iii 3,06,08,712 iv 19,03,08,020
2. i Thirty four thousand twenty five



EXERCISE - 2.1

1. i T ii T
iii F [All natural numbers are whole numbers] iv T
v F [The whole number on the left of another number on the number line, is smaller]
vi F [We can show the smallest whole number on the number line.]
vii F [We can't check the greatest whole number on the number line]

2. 18

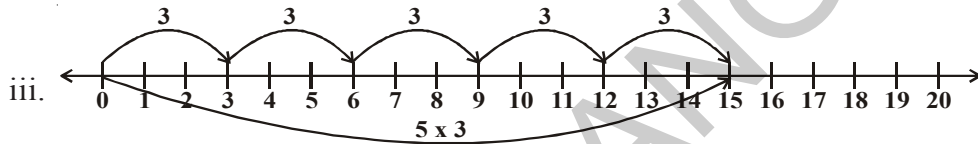
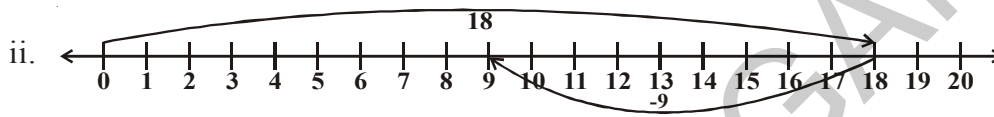
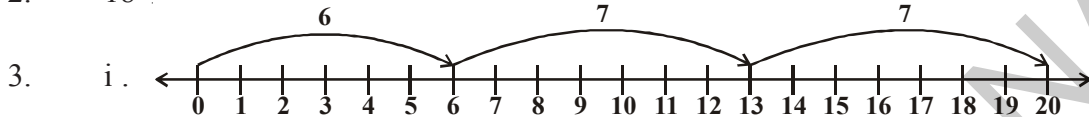

4. i 895 is on the right of 239 ii 10001 is on the right of 1001
iii 10015678 is on the right of 284013

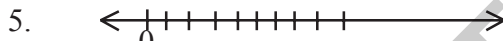

6. i > ii > iii < iv > 7.



EXERCISE - 2.2

1. i 532 ii 47 iii c iv 100 v 85 vi d
2. i 1095 ii 600
3. i 196300 ii 1530000 4. i 11040 ii 388710
5. i 407745 ii 2000955
6. ₹3000 7. ₹330
8. i c ii e iii b iv a v d



EXERCISE - 2.3

1. $123456 \times 8 + 6 = 987654$
 $1234567 \times 8 + 7 = 9876543$
 $12345678 \times 8 + 8 = 98765432$

2. $91 \times 11 \times 4 = 4004$
 $91 \times 11 \times 5 = 5005$
 $91 \times 11 \times 6 = 6006$
 $91 \times 11 \times 7 = 7007$
 $91 \times 11 \times 8 = 8008$
 $91 \times 11 \times 9 = 9009$
 $91 \times 11 \times 10 = 10010$



EXERCISE - 3.1

1. Divisible by 2 -- ii, iii, iv, v, vi, viii
 Divisible by 3 -- i, ii, iii, iv, v, vii
 Divisible by 6 -- ii, iii, iv, v
2. Divisible by 5 -- 25, 125, 250, 1250, 10205, 70985, 45880
 Divisible by 10 -- 250, 1250, 45880
5. 12345 is divisible by 3, 5
 54321 is divisible by 3.
7. i. 2, 8 ii. 0, 9 iii. 1, 7
8. 2 9. 6



EXERCISE - 3.2

1. i. 1, 2, 3, 4, 6, 9, 12, 18, 36 ii. 1, 23
 iii. 1, 2, 3, 4, 6, 8, 12, 16, 24, 32, 48, 96 iv. 1, 5, 23, 115
2. i, ii 3. 19
4. Prime number- 11, 13, 17, 19, 23, 29
 Composite number- 12, 14, 15, 16, 18, 20, 21, 22, 24, 25, 26, 27, 28
5. 13-31, 79-97 6. (3, 5), (5, 7), (11, 13), (17, 19)
7. 5 and 7 8. 13, 23
9. 90 to 96 10. (31, 11, 11); (13, 17, 23); (3, 19, 31) etc
11. (3, 13); (7, 17); (23, 13)... 12. (2, 3); (3, 7); (7, 13) etc



EXERCISE - 3.3

1. i

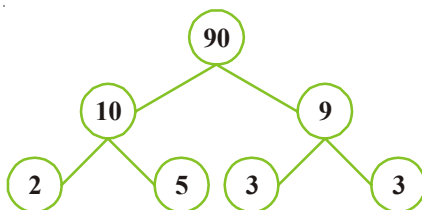

- ii

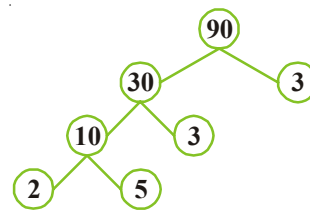



EXERCISE - 4.1

1. i. \overline{AB} , \overline{BC} , \overline{AC}
ii. \overline{PQ} , \overline{QR} , \overline{RS} , \overline{ST} , \overline{PT} , \overline{PR} , \overline{PS} , \overline{QS} , \overline{QT} and \overline{RT}
3. i. uncountable/many ii. one
4. iii. line segment
5. i. two ii. one iii. none
6. i. T ii. T iii. F iv. F v. T



EXERCISE - 4.2

1. i ii iv
2. Open (i., v) closed (ii, iii., iv)
3. Interior (A, B, E, G, I), boundary (K, F, C), exterior (J, D)



EXERCISE - 4.3

1. ii. $\angle BOC$, O , \overline{OB} , \overline{OC} iii. $\angle COD$, O , \overline{OC} , \overline{OD}
iv. $\angle DOA$, O , \overline{OA} , \overline{OD}
2. $\angle BAD$, $\angle ABC$, $\angle BCD$, $\angle ADC$
4. i., iii.



EXERCISE - 4.4

2. i. PS ii. $\angle R$ iii. PS and QR iv. $\angle P$ and $\angle R$
3. i. S, R ii. A, B, C, D, E iii. T, P, Q



EXERCISE - 4.5

3. i. T ii. T iii. T iv. F v. F



EXERCISE - 5.1

3. Largest line segment is AE.
4. Reshma located correct.



EXERCISE - 5.2

1.
 - i True
 - ii False A right angle measure 90°
 - iii False A straight angle measure 180°
 - iv True
 - v True
2. Acute angle $\angle 1, \angle 3$
Obtuse angle $\angle 2, \angle 4$
3. $\angle ABC = 60^\circ$
 $\angle FED = 120^\circ$
 $\angle RQP = 90^\circ$
 $\angle FED$ is the largest angle
4.

i right angle	ii straight angle
iii zero angle	iv obtuse angle
v reflex angle	
5. Acute angle, 45°
Right angle, 90°
Obtuse angle, 150°
Reflex angle, 270°
Straight angle, 180°



EXERCISE - 5.3

1.

i Parallel lines	ii Parallel lines	iii perpendicular
iv Neither of them	v Parallel	
3. Parallel lines $AB \parallel CD, AD \parallel BC$
Perpendicular $AD \perp AB, AB \perp BC, BC \perp CD, CD \perp DA$
Pair of intersecting line AC, BD



EXERCISE - 6.1

1. i. + 3000 meters ii. -10 meters
 iii. + 35°C iv. 0°C
 v. -36°C vi. -500 meters
 vii. -19°C viii. +18°C
2. (-1, -2, -3, -4, -5 etc.)
3. (1, 2, 3, 4, 5 etc.)

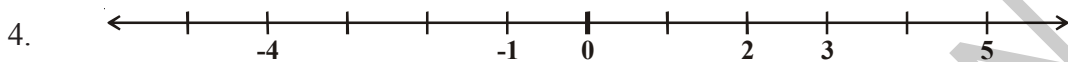

5. i. [False, left side] ii. [False]
 iii. [True] iv. [True]



EXERCISE - 6.2

1. i. < ii. > iii. < iv. > v. < vi. <
2. i. (-7, -3, 5) ii. (-1, 0, 3)
 (5, -3, -7) (3, 0, -1)
 iii. (-6, 1, 3) iv. (-5, -3, -1)
 (3, 1, -6) (-1, -3, -5)
3. i. (True) ii. (False, -12 is negative integer and + 12 is positive integer)
 iii. (True) iv. (True)
 v. (False, $-100 < + 100$) vi. (False, $-1 > -8$)
4. i. 0 ii. -4, -3, -2, -1
 iii. -7 iv. -1, -2

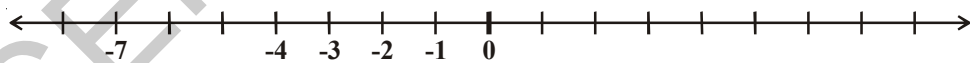

5. Kufri, $-6^{\circ}\text{C} < 4^{\circ}\text{C}$



EXERCISE - 6.3

1. i. 1 ii. -10 iii. -9
 iv. 0 v. -16 vi. 3
2. i. 7 ii. 6 iii. 0
 iv. -115 v. -132 vi. 6
3. i. -154 ii. -40 iii. 199 iv. 140
4. i. 6 ii. -78 iii. -64 iv. 25



EXERCISE - 6.4

1. i. 18 ii. -14 iii. -33
 iv. -33 v. 44 vi. 19
2. i. < ii. > iii. > iv. =
3. i. 13 ii. 0 iii. -9 iv. -6
4. i. -13 ii. 21 iii. -33 iv. 88



EXERCISE - 7.1

1. ii, iii
2. iv, v
- $$\left[\begin{array}{l} \frac{13}{2} \text{ between 6 and 7} \\ \frac{7}{3} \text{ between 2 and 3} \end{array} \right]$$
3. ii, iv
4. i. $2\frac{1}{3}$ ii. $5\frac{1}{2}$ iii. $2\frac{1}{4}$ iv. $6\frac{3}{4}$ 5. i. $\frac{9}{7}$ ii. $\frac{26}{8} = \frac{13}{4}$ iii. $\frac{92}{9}$ iv. $\frac{79}{9}$



EXERCISE - 7.2

1. i, ii
3. i. $\left(\frac{2}{3}, \frac{5}{3}, \frac{1}{3}, \frac{4}{6} = \frac{2}{3}\right)$ ii. $\left(\frac{3}{5} \text{ and } \frac{2}{5}\right)$ iii. $\left(\frac{7}{8}, \frac{2}{8}\right)$



EXERCISE - 7.3

1. Ascending Descending
- i. $\frac{1}{8} < \frac{3}{8} < \frac{4}{8} < \frac{6}{8}$ or $\frac{6}{8} > \frac{4}{8} > \frac{3}{8} > \frac{1}{8}$
- ii. $\frac{3}{9} < \frac{4}{9} < \frac{6}{9} < \frac{8}{9}$ Write in descending order yourself.



$$\frac{2}{6} < \frac{4}{6} < \frac{5}{6} < \frac{6}{6} < \frac{8}{6}$$

3. i $\frac{1}{6} < \frac{1}{3}$ ii $\frac{3}{4} > \frac{2}{6}$ iii $\frac{2}{3} > \frac{2}{4}$

iv $\frac{6}{6} = \frac{3}{3}$ v $\frac{5}{6} < \frac{5}{5}$

4. i $\frac{1}{2} > \frac{1}{5}$ ii $\frac{2}{4} = \frac{3}{6}$ iii $\frac{3}{5} < \frac{2}{3}$

iv $\frac{3}{4} > \frac{2}{8}$ v $\frac{3}{5} < \frac{6}{5}$ vi $\frac{7}{9} > \frac{3}{9}$

5. i No ; because $\frac{4}{5}$ is greater than $\frac{5}{9}$

ii No ; $\frac{9}{16}$ is greater than $\frac{5}{9}$

iii Yes $\frac{4}{5} = \frac{16}{20}$; $\frac{16}{20} = \frac{4}{5}$

iv No, because $\frac{4}{30}$ is greater than $\frac{1}{15}$; $\frac{4}{30} = \frac{2}{15} > \frac{1}{15}$

6. Varshith, because Lalita read $\frac{2}{5}$ of 100 that is 40 pages.

7. i + ii - iii +

8. i $\frac{2}{18} = \frac{1}{9}$ ii $\frac{11}{15}$ iii $\frac{2}{7}$ iv $\frac{22}{22} = 1$

v $\frac{5}{15}$ vi $\frac{8}{8} = 1$ vii $\frac{1}{3}$ viii $\frac{1}{4}$ ix $\frac{3}{5}$

9. i $\frac{4}{10}$ ii $\frac{8}{21}$ iii $\frac{9}{6}$ iv $\frac{7}{27}$

10. 1 (Complete wall) 11. $\frac{2}{7}$ 12. $\frac{5}{8}$

13. Snigdha takes less time she takes $\frac{9}{20}$ minutes less to walk across the school ground.



EXERCISE - 7.4

1. i $\frac{8}{10}$ ii 15 iii 9 iv $\frac{8}{10}$ v decimal point
2. i 125.4 ii 20.2 iii 8.6
3. i 0.16 ii 0.278 iii 0.06 iv 3.69
v 0.016 vi 34.5 vii 9.07
4. i 4 ii $\frac{8}{100}$ iii $\frac{9}{10}$ iv $\frac{5}{10}$
v $\frac{3}{100}$ vi $\frac{7}{10}$
5. i 0.4 ii 70.7 iii 6.6 iv 7.4 v. 0.8
6. i $0.04 < 0.14 < 1.04 < 1.14$ ii $0.99 < 1.1 < 7 < 9.09$
7. i $8.8 > 8.6 > 8.59 > 8.09$ ii $8.68 > 8.66 > 8.06 > 6.8$



EXERCISE - 7.5

1. i ₹ 1.25 ii ₹ 0.75 iii ₹ 3.75
2. i 28.91 ii 17.09 iii 10.46 iv 21.24 v 6.32
3. 8 km. 845 meter
4. 12 m



EXERCISE - 9.1

- i $2m$ ii $4m$ iii $3m$
- $3n$
- i $2s$ ii $3s$
- $7n$ 5. $90m$ 6. ₹ 23
- $(x-2)$
- $2y+3$
- $6z$
- (i) 8, 11, 14, 17, 29, 12 (ii) 14, 29, 34, 44, 39, 10
- i 19 ii $3+2(n-1)=2n+1$



EXERCISE - 9.2

- i $5q$ ii $\frac{y}{4}$ iii $\frac{pq}{4}$ iv $3z+5$
v $9n+10$ vi $2y-16$ vii $10y+x$
- $3p$ 4. $x+3$ 5. $5n$



EXERCISE - 9.3

- i, iv, v, viii, x, xi, xii
- i LHS = $x-5$ RHS = 6
ii LHS = $4y$ RHS = 12
iii LHS = $2z+3$ RHS = 7
iv LHS = $3p$ RHS = 24
v LHS = 4 RHS = $x-2$
vi LHS = $2a-3$ RHS = -5
- i $x=2$ ii $y=9$ iii $a=8$
iv $p=3$ v $n=5$ vi $z=9$



EXERCISE - 10.1

- 230 cm., 48 cm., 24 cm., 40 cm.
- Perimeters are 120 cm, 120 cm., 120 cm., 144 cm. and cost of wire are ₹ 1800, ₹1800, ₹1800, ₹2160 respectively.
- 6 rectangles, measurements are (11,1) (10,2) (9,3) (8,4) (7,5) (6, 6) 4. ₹ 840
- i 20 cm ii 15 cm iii 10 cm iv 12 cm
- Bunty ; 60 m 7. length - 16 cm Breadth-8 cm 8. 10 cm
- i 12 cm ii 27 cm iii 22 cm



EXERCISE - 10.2

- i 1000 cm² ii 2925 m² iii 400 cm² iv 133 km²
- i 676 m² ii 289 m² iii 2704 cm² iv 64 cm²
- 45 cm 4. 1800 m²
- length of side = 10 cm ; Area = 100 cm²
- 24 m²; ₹ 5760
- Square plot ; 64m² 8. 4.7 cm, Square
- The cost of fencing Rahul's field = ₹ 1,80,000
The cost of fencing Ramu's field = ₹ 1,80,000
Ramu can plant more trees ; 1000 trees more
- 80 m 11. ₹ 26,400
- ₹ 5,04,000
- i Area increases by 4 times ii Area increases by 6 times
- i Area increases by 4 times ii Area become $\frac{1}{4}$ of the original area.



EXERCISE - 11.1

- 7 : 11
 - 2 : 3
 - 5 : 8
 - 3 : 5
- 2
 - 1/2
 - 2 : 1
- 1 : 4
 - chilli : pulses = 1 : 80
pulses : chilli = 80 : 1
 - 1 : 1



EXERCISE - 11.2

- Simplest form- i, iii, v, vi
 - 16 : 20 → 4 : 5
 - 20 : 60 → 1 : 3
- Rice : wheat rice : total
 - 1 : 3
 - 1 : 4
- 5 : 3
 - 5 : 8
 - 3 : 8
- 4 : 1
- 20 : 60, simplest form is 1 : 3
- 2 : 5



EXERCISE - 11.3

- 15
 - 10
- A X = 6 cm XB = 8 cm
- Geeta = ₹ 450, Laxmi = ₹ 600
- Satya = ₹ 1350, Vishnu = ₹ 2250
- numbers are 60 and 72
- income = 6534, saving = 1188



EXERCISE - 11.4

- ₹ 75
- ₹ 24
- 525 gram
- 20 chairs
- 12 hrs
- ₹ 25000
 - 19 months (1 year 7 months)
- ₹ 210
- 480 sheeps
 - 8 : 11
 - 11 : 3
- No, By changing the order as 3, 5, 9, 15 and 5, 3, 15, 9
- 5°C
- $\frac{15}{18} = \frac{5}{6} = \frac{10}{12} = \frac{25}{30}$

12.

Breadth	10	20	40
Length	25	50	100

13. i. 3 : 1 ii. 1 : 4 iii. 3 : 4

14. i. 5 : 4 ii. 4 : 5

15.

Yellow	2	4	6	8	10
Green	6	12	18	24	30
Total Sweets	8	16	24	32	40

i. 3 : 1 ii. 24 iii. 8 iv. 30 v. 64

16.

Girls	4	8	12	16	20
Boys	5	10	15	20	25
Total	9	18	27	36	45

i. 4 : 5 ii. 12 iii. 30 iv. 25



EXERCISE - 12.2

3. i 4 ii 1 iii 2 iv 0

v 4 vi 2

5. i 3 ii 1 iii 0 iv 2

v 6 vi Uncountable lines which passes through the centre of the circle.



EXERCISE - 14.1

1.

Faces	Edges	Vertices
4	6	4

2.

F	E	V
5	8	5

3.

Cone	1	1	1
Cylindre	1	2	Nil
Sphere	1	Nil	Nil

4. Traingular faces 2, Rectangular faces 3, edges 9, vertices 6



EXERCISE - 14.2

1. i Not, because polygon is a closed figure made by straight lines ii Yes

iii not, see the above answer and find.

2. i pentagon ii octagon iii hexagon iv triangle

INSTRUCTIONS TO TEACHERS

Dear Teachers

Greetings and a hearty welcome to the newly developed textbook Mathematics for class VI.

- The present textbook is developed as per the syllabus and academic standards conceived by the mathematics position paper prepared based on SCF – 2011 and RTE – 2009 for Upper Primary stage of education.
- The new textbook constitutes 14 chapters with concepts from the main branches of mathematics like Number system, Arithmetic, Algebra, Geometry, Mensuration and Statistics.
- The concepts in these chapters emphasize the prescribed academic standards of Problem Solving, Reasoning-proof, Communication, Connections and representation. These are aimed at to develop the skills of observation of patterns, making generalization through deductive, inductive and logical thinking finding different methods for problem solving, questioning, interaction etc., and the utilization of the same in daily life.
- The situations, examples and activities given in the textbook are based on the competencies acquired by the child at Primary Stage. So the child participates actively in all the classroom activities and enjoys learning of Mathematics.
- Primary objective of teacher should be to achieve the “Academic standards” by involving students in the discussions and activities suggested in the textbook and making them to understand the concepts.
- Mere completion of a chapter by teacher doesn't make any sense. The skills specified in the syllabus and academic standards prescribed should be exhibited by the student only ensures the completion of the chapter.
- Students should be encouraged to answer the questions given in the chapters. These questions help to improve logical, inductive and deductive thinking of the child.
- Understanding and generalization of properties are essential. Student first finds the need and then proceeds to understand, followed by solving similar problems on his own and then generalises the facts. The strategy in the presentation of concepts followed.

- Clear illustrations and suitable pictures are given wherever it was found connection and corrects the misconception necessary.
- Exercises of 'Do This' and 'Try This' are given extensively after completion of each concept. Exercises given under 'Do This' are based on the concept taught. After teaching of two or three concepts some exercises are given based on them. Questions given under 'Try This' are intended to test the skills of generalization of facts, ensuring correctness of statements, questioning etc., 'Do This' exercise and other exercises given are supposed to be done by students on their own. This process helps the teacher to know how far the students can fare with the concepts they have learnt. Teacher may assist in solving problem given in 'Try This' sections.
- Students should be made to digest the concepts given in "what have we discussed" completely. The next chapter is to be taken up by the teacher only after satisfactory performance by the students in accordance with the academic standards designated for them (given at the end).
- Teacher should prepare his own problems related to the concepts besides solving the problems given in the exercises. Moreover students should be encouraged to identify problems from day- to-day life or create their own problems.
- Above all the teacher should first study the textbook completely thoroughly and critically. All the given problems should be solved by the teacher well before the classroom teaching.
- Teaching learning strategies and the expected learning outcomes, have been developed class wise and subject-wise based on the syllabus and compiled in the form of a Hand book to guide the teachers and were supplied to all the schools. With the help of this Hand book the teachers are expected to conduct effective teaching learning processes and ensure that all the students attain the expected learning outcomes.

Syllabus

Area & Chapters

Syllabus Description

<p>Number System (60 hrs)</p> <p>1. Knowing our Numbers</p> <p>2. Whole Numbers</p> <p>3. Playing with Numbers</p> <p>6. Integers</p> <p>7. Fractions and Decimals</p>	<p>(i) Knowing our Numbers</p> <ul style="list-style-type: none"> • Consolidating the sense of Number up to 99,999; Estimation of numbers, Comparison of numbers; Place value (recapitulation and extension); connectives: use of symbols =, <, >; Use of brackets. • Word problems on number operations involving large numbers up to a maximum of 6 digits in the answer (This would include conversions of units of length & mass from the larger to the smaller units). • Estimation of outcome of number operations. • Introduction to large numbers (a) up to lakhs and ten lakhs (b) up to crores and ten crores: International system of numbers (Millions..)
	<p>(ii) Whole numbers</p> <ul style="list-style-type: none"> • Natural numbers, whole numbers. • Properties of numbers (closure, commutative, associative, distributive, additive identity, multiplicative identity). • Number line. Seeing patterns, identifying and formulating rules to be done by children. • Utility of properties in fundamental operations.
	<p>(iii) Playing with Numbers</p> <ul style="list-style-type: none"> • Consolidating divisibility rules of 2,3,5,6,9,10. • Discovering divisibility rules of 4,8,11 through observing patterns. • Multiples and factors, Even/odd numbers, prime/composite numbers, Co-prime numbers. • Prime factorization, every number can be written as products of prime factors. • HCF and LCM BY prime factorization and division method. • Property: $LCM \times HCF = \text{product of two numbers}$. • LCM & HCF of co-primes. • Importance of Zero, and its properties
	<p>(iv) Negative Numbers and Integers</p> <ul style="list-style-type: none"> • How negative numbers arise, models of negative numbers, connection to daily life, ordering of negative numbers, representation of negative numbers on number line. • Children to see patterns, identify and formulate rules. • Understanding the definition of integers, identification of integers on the number line. • Operation of addition and subtraction of integers, showing the operations on the number line (Understanding that the addition of negative integer reduces the value of the number). • Comparison of integers, ordering of integers.

	<p>(v) Fractions and Decimals</p> <ul style="list-style-type: none"> • Revision of what a fraction is, Fraction as a part of whole. • Representation of fractions (pictorially and on number line) • Fraction as a division, proper, improper & mixed fractions • Equivalent fractions, like, unlike fractions, comparison of fractions. • Addition and subtraction of fractions. • Word problems (Avoid large and complicated calculations). • Estimates the degree of closeness of a fractions ($\frac{1}{2}$, $\frac{1}{4}$, $\frac{3}{4}$ etc.,). • Review of the idea of a decimal fraction • Place value in the context of decimal fraction. • Inter conversion of fractions and decimal fractions (avoid recurring decimals at this stage). • Word problems involving addition and subtraction of decimals (word problems should involve two operations) Contexts: money, mass, length temperature.
<p>Algebra (15 hrs)</p> <p>9. Introduction Algebra</p>	<p>Introduction Algebra</p> <ul style="list-style-type: none"> • Introduction to variable through patterns and through appropriate word problems and generalizations (example $5 \times 1 = 5$ etc.). • Generate such patterns with more examples. • Introduction to unknowns through examples with simple contexts (single operations). • Number forms of even and odd ($2n$, $2n+1$). • Solving simple equations by trial and error method.
<p>Arithmetic (15hrs)</p> <p>11. Ratio and Proportion</p>	<p>Ratio and Proportion</p> <ul style="list-style-type: none"> • Concept of Ratio • Proportion as equality of two ratios • Unitary method (with only direct variation implied) • Word problems • Understanding ratio and proportion in Arithmetic
<p>Geometry (65 hrs)</p> <p>4. Basic geometrical ideas</p>	<p>Basic geometrical ideas (2-D)</p> <ul style="list-style-type: none"> • Introduction to geometry. Its linkage with and reflection in everyday experience. • Line, line segment, ray, open and closed figures. • Interior and exterior of closed figures. • Curvilinear and linear boundaries • Angle — Vertex, arm, interior and exterior, • Triangle — vertices, sides, angles, interior and exterior, altitude and median. • Quadrilateral — Sides, vertices, angles, diagonals, adjacent sides and opposite sides (only convex quadrilateral are to be discussed), interior and exterior of a quadrilateral. • Circle — Centre, radius, diameter, interior and exterior, arc, chord, sector, segment, semicircle, circumference,

<p>5. Measures of Lines and Angles</p> <p>12. Symmetry</p> <p>13. Practical Geometry</p> <p>14. Understanding 3D, 2D Shapes</p>	<p>Measures of Lines and Angles:</p> <ul style="list-style-type: none"> • Measure of Line segment. • Measure of angles. • Types of angles- acute, obtuse, right, straight, reflex, complete and zero angle. • Pair of lines Intersecting and perpendicular lines Parallel lines.
	<p>Symmetry:</p> <ul style="list-style-type: none"> • Observation and identification of 2-D symmetrical objects for reflection symmetry. • Operation of reflection (taking mirror images) of simple 2-D objects. • Recognising reflection symmetry (identifying axes).
	<p>Practical Geometry (Constructions):</p> <ul style="list-style-type: none"> • Drawing of a line segment (using Straight edge Scale, protractor, compasses). • Construction of circle. • Perpendicular bisector. • Construction of angles (using protractor) • Angle 60°, 120° (Using Compasses) • Angle bisector - making angles of 30°, 45°, 90° etc. (using compasses) • Angle equal to a given angle (using compass) • Drawing a line perpendicular to a given line from a point <ul style="list-style-type: none"> a) on the line b) outside the line.
	<p>Understanding 3D, 2D Shapes:</p> <ul style="list-style-type: none"> • Polygons- Introduction, regular and irregular polygons (upto pentagon). • Identification of 3-D shapes: Cubes, cuboids, cylinder, sphere, cone, prism (triangular), pyramid (triangular and square). Identification and locating in the surroundings • Elements of 3-D figures. (Faces, edges and vertices) • Nets for cube, cuboids, cylinders, cones and tetrahedrons.
<p>Mensuration (15 hrs)</p> <p>10. Perimeter and Area</p>	<p>Perimeter and Area:</p> <ul style="list-style-type: none"> • Introduction and general understanding of perimeter using many shapes. • Shapes of different kinds with the same perimeter. • Concept of area, Area of a rectangle and a square Counter examples to different misconceptions related to perimeter and area. • Perimeter of a rectangle – and its special case – a square. • Deducing the formula of the perimeter for a rectangle and then a square through pattern and generalisation.
<p>8. Data Handling (10 hrs)</p>	<p>Data Handling:</p> <ul style="list-style-type: none"> • What is data. • Collection and organisation of data - examples of organising it in tally marks and a table. • Pictograph- Need for scaling in pictographs interpretation & construction. • Making bar graphs for given data, interpreting bar graphs.

Academic Standards

CONTENT

ACADEMIC STANDARDS

CONTENT	ACADEMIC STANDARDS
Number system 1. Knowing our numbers	Problem Solving <ul style="list-style-type: none"> • Word problems on number operations involving large numbers up to a maximum of 5 digits in the answers. • Conversions of units of length and mass.
	Reasoning, Proof <ul style="list-style-type: none"> • Estimation of outcome of number operations. • Comparison of numbers up to large numbers with concept of place value. • Formation of different numbers by using given numbers and select biggest, smallest among them.
	Communication: <ul style="list-style-type: none"> • Writes any five digit numbers in words and vice versa. • Comparison of five digit numbers using the symbols $<$, $>$, $=$.
	Connections: <ul style="list-style-type: none"> • Understands the Usage of large numbers in daily life (village population, income from land, etc.)
	Representation: <ul style="list-style-type: none"> • Expresses the numbers into expanded and compact form • By using unit, ten, hundred, thousand blocks represents numbers through them.
2. Whole numbers	Problem Solving <ul style="list-style-type: none"> • Solves problems by using four fundamental operations with the properties of whole numbers.
	Reasoning, Proof <ul style="list-style-type: none"> • Verification of properties of whole numbers such as closure, associative, inverse, identity, distributive, commutative (+, -, x)
	Communication: <ul style="list-style-type: none"> • Understands the need of whole number instead of natural numbers.
	Connections: <ul style="list-style-type: none"> • Finds the usage of whole numbers from their daily life. • Understands the relation between N, and W.
	Representation: <ul style="list-style-type: none"> • Represents the whole numbers on the number line.
3. Playing with Numbers	Problem Solving <ul style="list-style-type: none"> • Simplification of numerical statements involving two or more brackets • Tests the divisibility rules • Understands the use of LCM and HCF in different situations and find them in division, prime factorization method.

	Reasoning, Proof	<ul style="list-style-type: none"> • Finds the logic behind the divisibility rules. • Understands the relationship between LCM and HCF of two numbers by verification, why this relation hold only in two numbers, take more than two numbers and see the pattern, conclude
	Communication:	• Uses brackets involving fundamental operations.
	Connections:	<ul style="list-style-type: none"> • Establishes the relation among factors. • Under stands the use of LCM and HCF from their real life situations. • Finds the patterns in division, multiplication tables.
	Representation:	• _____
6. Integers	Problem Solving	• Solves the problems on addition, subtraction and multiplication involving integers.
	Reasoning, Proof	<ul style="list-style-type: none"> • Compares integers, and ordering of integers. • Difference of +, - between N, and Z.
	Communication:	• Understands the necessity of set of integers.
	Connections:	• Finds the connection among N,W and Z.
	Representation:	<ul style="list-style-type: none"> • Represents the integers on the number line. • Shows the addition, subtraction on the number line.
7. Fractions and Decimals	Problem Solving:	<ul style="list-style-type: none"> • Adds, subtracts, multiplies like and unlike fractions (avoid complicated, large tasks) • Inter conversion of fractions and decimal fractions. • Word problems involving +, - of decimals (two operations together on money, mass, length, temperature)
	Reasoning, Proof:	<ul style="list-style-type: none"> • Gives reasons in conversion of mixed fractions and improper fractions. • Compares fractions.
	Communication:	• Express improper fraction into mixed fraction and vice-versa.

	Connections: <ul style="list-style-type: none"> • Connections between fraction, decimal fractions, decimal numbers
	Representation: • Represents fractions on number line.
Algebra 9. Introduction Algebra	Problem Solving <ul style="list-style-type: none"> • Finds the value of the expression when substituting a value in place of variable (Simple expressions can be taken and single operation)
	Reasoning, Proof <ul style="list-style-type: none"> • Generalizes the given patterns and express as algebra expression.
	Communication: • Converts the real life simple contexts into Algebraic expression (vice versa)
	Connections: <ul style="list-style-type: none"> • Finds the usage of algebraic expression when occurring the unknown values. • Inter links the number system with algebraic system by usage of simple contexts.
	Representation: • Represents the even, odd number in general form as $2n, 2n+1$.
Arithmetic 11. Ratio and Proportion	Problem Solving <ul style="list-style-type: none"> • Calculates inverse ratio, compound of two ratios. • Solves word problem involving unitary method
	Reasoning, Proof <ul style="list-style-type: none"> • Compares the given ratios. • Verifies the rule of proportion involving the ratios. • Gives the reasons why the same units can be taken in expressing of ratios.
	Communication: • Write ratios in symbols and equivalent fractional form.
	Connections: <ul style="list-style-type: none"> • Observes the relation between time and work, time and distance using proportions. • Understands the usage of ratios and proportion in daily life problems.
	Representation: • _____

Geometry 4. Basic Geometrical Ideas	Problem Solving <ul style="list-style-type: none"> • _____
	Reasoning, Proof <ul style="list-style-type: none"> • Differentiates the basic geometric shapes (triangle, circle, Quadrilaterals) • Differentiates and compares the Quadrilaterals and triangle.
	Communication: • Gives the example of basic geometry shapes (from surface of the surrounding objects).
	Connections: <ul style="list-style-type: none"> • Visualizes the basic geometric shapes from surroundings. • Understands the inter relation between various components of a circle (Circle, Semi Circle, Sector, Diameter, Radius, chord etc).
	Representation: • Gives pictorial representation of basic geometric shapes.
5. Measures of Lines and Angles	Problem Solving <ul style="list-style-type: none"> • Measures the given line segment
	Reasoning, Proof <ul style="list-style-type: none"> • Compares the lengths of line segments by estimation and verification. • Classifies the given angles. • Differentiates the pair of lines as intersecting, perpendicular lines. • Estimates the type of given angle. • Compares the given angle. • Rounds off an angle to nearest measure by estimation.
	Communication: • Finds the usage of elementary shapes and their measurements in surroundings.
	Connections: <ul style="list-style-type: none"> • Draws a line segment with given measurement. • Draws the given angle using apparatus.
	Representation: • _____

12.Symmetry	Problem Solving	<ul style="list-style-type: none"> • Finds the symmetric axis of given 2D shapes.
	Reasoning, Proof	<ul style="list-style-type: none"> • Distinguishes symmetrical and non symmetrical shapes. • Explains the reflection symmetry in the given 2D figure
	Communication:	• Explains reflection symmetry with its axis in 2D objects
	Connections:	<ul style="list-style-type: none"> • Observes and identify the reflective symmetry from surroundings. • Appreciates the reflection symmetric nature in surroundings.
	Representation:	• Draws the symmetric axis in the given 2D figures
13.Practical Geometry	Problem Solving	• _____
	Reasoning, Proof	<ul style="list-style-type: none"> • Estimates the given pair of lines whether they are perpendicular or not. • Estimates the given line whether it is angle bisector or not
	Communication:	• Communicate how constructions made in line segment, Circle, Perpendicular bisector, angle, angle bisector.
	Connections:	• _____
	Representation:	• Draws the line segment, circle, perpendicular bisector, angle, angle bisector.
14.Understanding 3D, 2D Shapes	Problem Solving	• _____
	Reasoning, Proof	<ul style="list-style-type: none"> • Differentiates polygon and regular polygon. Check whether given polygon is regular or not. Give reasons. • Differentiates the 3D shapes as per faces edges, vertices (Cube, Cuboids, Cylinder, Sphere, Cone, Prism, Pyramid)
	Communication:	• _____

	Connections: <ul style="list-style-type: none"> Establish the relation between polygons and their names. Identifies the 3D shape by their names from surroundings. Understands the relation between cube, cuboid, cylinder and their nets.
Mensuration 10. Perimeter and Area	Representation: <ul style="list-style-type: none"> Identifies suitable objects for drawing regular polygons. Represents 3D shape as 2D on paper.
8. Data Handling	Problem Solving <ul style="list-style-type: none"> Solves the problems involving perimeter and area of rectangle and square. Solves word problems
	Reasoning, Proof <ul style="list-style-type: none"> Differentiates perimeter and area of a figure. Finds the perimeter of a given figure, involving more than 2 shapes. Gives the measurements of rectangle/ square which have same area but different perimeters. Identifies the same perimeter with different shapes from given shapes. Finds errors in solving of perimeter, area and rectifying them.
	Communication: Perimeter / area of rectangle / square is expressed in formulae and in words also
	Connections: <ul style="list-style-type: none"> Establishes relation between units to area and perimeter.
	Representation: Shows the area of the polygon by shading the region.
	Problem Solving <ul style="list-style-type: none"> Organization of raw data into classified data.
	Reasoning, Proof <ul style="list-style-type: none"> Interpretation of tabular data into verbal form.
	Communication: Merits, demerits of bar graphs and pictographs.
	Connections: <ul style="list-style-type: none"> Understands the usage of bar graphs, pictographs in daily life situations (Year-wise population, Annual Budget, Production of crops etc).
	Representation: <ul style="list-style-type: none"> Represents data in tally marks. Represents data in tabular forms. Represents data into bar graphs and pictographs.

LEARNING OUTCOMES

MATHEMATICS

CLASS 6

The learner....

- Reads the larger numbers in Indo-Arabic, English systems and compares the numbers.
- Applies L.C.M. and H.C.F. in real life situations.
- Explains properties of whole numbers. Explains significance of zero also.
- Solves problems involving addition and subtraction of integers.
- Solves problems in real life situations by using ratio and proportions.
- Solves problems in daily life situations involving addition and subtraction of fractions and decimals.
- Expresses relationships in a given situation in daily life in the form of an expression or equation by using variable. .
- Demonstrates an understanding of geometrical ideas like point, line segment, straight line, ray and curve.
- Identifies simple closed figures. Expresses angle, vertex and side of the figure in mathematical notations.
- Identifies circle and parts (center, diameter, radius, arc, and sector) in it and explains.
- Calculates perimeters of regular polygons and area of a given rectangle.
- Represents the data collected from real life situations in a tabular form by using tally marks and in a pictorial form and a bar graph.
- Identifies 3D shapes like sphere, cube, cuboids, cylinder, cone in real life situations on the basis of their fundamental properties.
- Demonstrates symmetry in objects by using symmetrical line.
- Draws multiple symmetrical lines to the figures wherever possible.



పాఠశాల విద్యా బాధా,
తెలంగాణ ప్రభుత్వం



विद्यया ऽ मृतमश्नुते

एन सी ई आर टी
NCERT

TEXT BOOK DEVELOPMENT TEAM - 2012

Chief Advisors

Professor V. Kannan, Dept. of Mathematics and Statistics, University of Hyderabad

Dr. H.K. Dewan, Education Advisor, Vidya Bhawan Society Resource Centre, Udaipur, Rajasthan.

Editors

Smt.B. Seshu Kumari, Director, SCERT, Hyderabad.

Sri. K. Bramhaiah, Professor, SCERT, Hyderabad

Sri. P. Adinarayana, Retd., Lecturer, New Science College, Ameerpet, Hyderabad

Writers

Sri. K.K.V. Rayalu, Lecturer, Govt., IASE, Masabtank, Hyderabad, Coordinator

Sri. Kakulavaram Rajender Reddy, SA, UPS Thimmapur, Chandampet, Nalgonda, Coordinator

Sri. Dr. P. Ramesh, Lecturer, Govt. IASE, Nellore

Sri. M. Ramanjaneyulu, Lecturer, DIET, Vikarabad, Ranga Reddy

Sri. T.V. Rama Kumar, HM, ZPHS, Mulumudi, Nellore

Sri. P. Ashok, HM, ZPHS, Kumari, Adilabad

Sri. P. Anthoni Reddy, HM, St. Peter's High School, R.N.Peta, Nellore

Sri. S. Prasada Babu, PGT, APTWR School, Chandrashekarapuram, Nellore

Sri. Kakulavaram Rajender Reddy, SA, UPS Thimmapur, Chandampet, Nalgonda

Sri. G.V.B.Suryanarayana Raju, SA, Municipal High School, Kaspa, Vizianagaram

Sri. S. Narasimha Murthy, SA, ZPHS, Mudivarthipalem, Nellore

Sri. P. Suresh Kumar, SA, GHS, Vijayanagar Colony, Hyderabad

Sri. K.V. Sunder Reddy, SA, ZPHS, Thakkasila, Alampur Mdl., Mababoobnagar

Sri. G. Venkateshwarlu, SA, ZPHS, Vemulakota, Prakasham

Sri. Ch. Ramesh, SA, UPS, Nagaram (M), Guntur.

Sri. P.D.L. Ganapathi Sharma, SA, GHS, Jamisthanpur, Manikeshwar Nagar, Hyderabad

Academic Support Group

Smt. Namrita Batra, Vidyabhavan Society Resource Centre, Udaipur, Rajasthan

Sri. Inder Mohan, Vidyabhavan Society Resource Centre, Udaipur, Rajasthan

Sri. Yashwanth Kumar Dave, Vidyabhavan Society Resource Centre, Udaipur, Rajasthan

Smt. Padma Priya Sherali, Community Mathematics Centre, Rishi Vally School, Chittoor

Kumari. M. Archana, Dept. of Mathematics & Statistics, University of Hyderabad

TEXTBOOK DEVELOPMENT TEAM - 2012

Illustrators

Sri. Prashanth Soni, Artist, Vidyabhavan Society Resource Centre, Udaipur, Rajasthan.

Sri. S.M. Ikram, Operator, Vidyabhavan Society Resource Centre, Udaipur, Rajasthan.

Sri. Kannaiah Dara, Battapothula Gudem, Dandampally, Nalgonda.

Sri. R. Madhusudhana Rao, SCERT, Hyderabad.

Layout and Cover Page Designer

Sri. K. Sudhakara Chary, HM, UPS Neelikurthy, Mdl.Maripeda, Dist. Warangal

Text Book Publication Team

Director, SCERT, Hyderabad.

Director, Govt. Text Book Press, Hyderabad.

Prof. & HOD, Dept of Curriculum & Text Books, SCERT, Hyderabad.

QR CODE TEAM



Energized Text Books facilitate the students in understanding the concepts clearly, accurately and effectively. Content in the QR Codes can be read with the help of any smart phone or can as well be presented on the Screen with LCD projector/K-Yan projector. The content in the QR Codes is mostly in the form of videos, animations and slides, and is an additional information to what is already there in the text books.

This additional content will help the students understand the concepts clearly and will also help the teachers in making their interaction with the students more meaningful.





At the end of each chapter, questions are provided in a separate QR Code which can assess the level of learning outcomes achieved by the students.

We expect the students and the teachers to use the content available in the QR Codes optimally and make their class room interaction more enjoyable and educative.

Let us know how to use QR codes

In this textbook, you will see many printed QR (Quick Response) codes, such as 

Use your mobile phone or tablet or computer to see interesting lessons, videos, documents, etc. linked to the QR code.

Step	Description
A.	Use Android mobile phone or tablet to view content linked to QR Code:
1.	Click on Play Store on your mobile/ tablet.
2.	In the search bar type DIKSHA .
3.	
	will appear on your screen.
4.	Click Install
5.	After successful download and installation, Click Open
6.	Choose your preferred Language - Click English
7.	Click Continue
8.	Select Student/ Teacher (as the case may be) and Click on Continue
9.	On the top right, click on the QR code scanner icon  and scan a QR code  printed in your book
	OR
	Click on the search icon  and type the code printed below the QR code, in the search bar. (Q)
10.	A list of linked topics is displayed
11.	Click on any link to view the desired content
B.	Use Computer to view content linked to QR code:
1.	Go to https://diksha.gov.in/teelangana
2.	Click on Explore DIKSHA-TELANGANA
3.	Enter the code printed below the QR code in the browser search bar (Q)
4.	A list of linked topics is displayed
5.	Click on any link to view the desired content





IN ANY EMERGENCY



 **DIAL**

1000

TELANGANA POLICE

 www.tspolice.gov.in

  @ **Telangana State Police**





Government of Telangana

Department of Women Development & Child Welfare - Childline Foundation

When abused in or out of school.

To save the children from dangers and problems.



CHILD LINE 1098
NIGHT & DAY
24 HOUR NATIONAL HELPLINE

When the children are denied school and compelled to work.

When the family members or relatives misbehave.

1098 (Ten...Nine...Eight) dial to free service facility.